



Over Voltage and Over Current Protection IC

General Description

LP5303A is a single-channel overvoltage and programmable overcurrent protection device. The device integrates powerful protection and diagnostic functions to ensure the voltage and current stability of the output port, even in the event of harmful events such as input overvoltage, overcurrent and so on. In the meanwhile the device has short-circuit and thermal shutdown protection functions, which can be safely Turn off the output. The device also supports external adjustment of the current limit. This feature Performance by reducing the inrush current when driving large capacitive loads and as much as possible Overload current can improve the reliability of the system, thereby eliminating system undervoltage condition. The device protects against faults through reliable current limiting. According to different device requirements, the corresponding safe current set point can be configured to make the chip react to over-current events to protect the circuit system.

Order Information

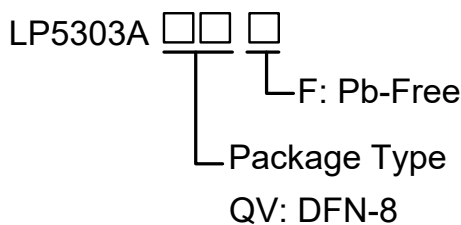

Applications

- ✧ Intelligent Wearable Device
- ✧ Digital Set-Top Box
- ✧ Adapter Power equipment
- ✧ PAD

Features

- ◆ Wide Input Voltage Range: 4V to 24V
- ◆ OVP Threshold: 6.1V
- ◆ OVP Threshold Time Less Than 1us
- ◆ Programmable Current Limit from 0.3A to 3A
- ◆ Low $R_{DS(ON)}$ Internal Switches: 110mΩ @ 5V /1A
- ◆ External logic Fault status signal function for OVP, OCP、Short-Circuit、 Thermal Shutdown
- ◆ Short-Circuit Protection
- ◆ Thermal Fault Protection
- ◆ Available DFN-8 2x3mm Package
- ◆ RoHS Compliant and 100% Lead (Pb)-Free

Typical Application Circuit

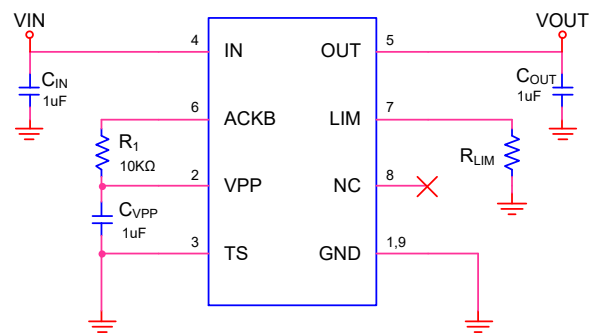

Marking Information

Device	Marking	Package	Shipping
LP5303AQVF	LPS LP5303A YW X	DFN-8	5K/REEL
Marking indication: Y:Production year W:Production week X:Production batch			



Functional Pin Description

Package Type	Pin Configuration
DFN-8	

Pin Description

PIN	Name	Description
1,9	GND	Ground.
2	VPP	Chip internal voltage regulator source. Provide ACKB signal pull-up source.
3	TS	Test pin has no function, generally recommended to be grounded.
4	IN	Input pin.
5	OUT	Output pin.
6	ACKB	Output status flag pin. The chip monitors the working voltage and current. This pin is set to low for normal operation, and high for triggering an abnormal event. This pin is in an open-drain state and needs to be pulled up to VPP when used.
7	LIM	Programmable current limit pin. Set the current limit of the chip by connecting resistors of different resistances to the ground. Floating default maximum current limit, grounded this pin is release with current limit.
8	NC	No connection.



Function Diagram

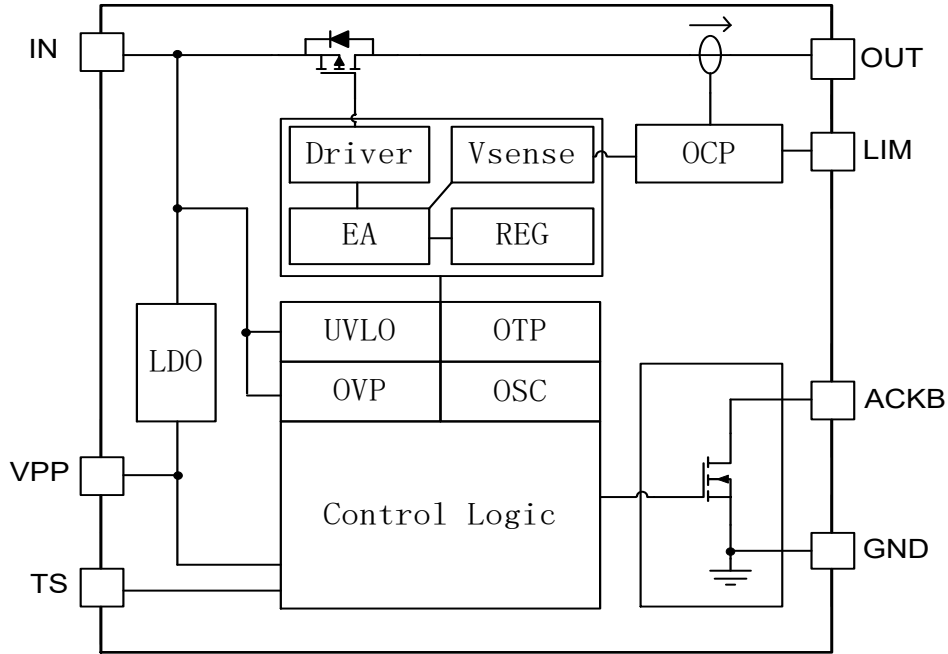

Absolute Maximum Ratings ^{Note 1}

- ◇ Input Voltage to GND ----- 25V
- ◇ Output Voltage to GND ----- 6.5V
- ◇ LIM Pin to GND ----- 3V
- ◇ Other Pin to GND ----- 6V
- ◇ Maximum Junction Temperature ----- 150°C
- ◇ Operating Ambient Temperature Range (T_A) ----- -40°C to 85°C
- ◇ Storage Temperature ----- -65°C to 150°C
- ◇ Maximum Soldering Temperature (at leads, 10 sec) ----- 260°C

Note 1. Stresses beyond those listed under "Absolute Maximum Ratings" may cause permanent damage to the device. These are stress ratings only, and functional operation of the device at these or any other conditions beyond those indicated in the operational sections of the specifications is not implied. Exposure to absolute maximum rating conditions for extended periods may affect device reliability.

Thermal Information

- ◇ Maximum Power Dissipation (DFN-8, P_D, T_A=25°C) ----- 1.2W
- ◇ Thermal Resistance (DFN-8, θ_{JA}) ----- 80°C/W

ESD Susceptibility

- ◇ HBM(Human Body Mode) ----- 2KV
- ◇ MM(Machine Mode) ----- 200V



Electrical Characteristics

(VIN=5V , TA=25°C, unless otherwise noted)

Symbol	Parameter	Condition	Min	Typ	Max	Units
Input voltage parameters and characteristics						
V _{IN}	Operating Input Voltage		4	5	24	V
I _Q	Input quiescent current	V _{IN} =5V		150		μA
R _{ON}	Turn-on internal resistance Include bonding wire	V _{IN} =5V, I _{OUT} =1A		110		mΩ
R _{DISCHARGE}	Output discharge resistance			2		kΩ
UVLO	UVLO Threshold Voltage	V _{IN} Rising	2.3	2.5		V
V _{HYS-UVLO}	UVLO Hysteresis	V _{IN} Decline		150		mV
T _{SS_Delay}	Soft start delay time	V _{IN} =0->5V to 10% output voltage		35		mS
Over-Voltage-Protection (OVP) Input						
V _{OVP}	OVP threshold	V _{IN} Rising from 5~7V	5.95	6.1	6.25	V
V _{HYS-OVP}	OVP hysteresis	V _{IN} from OVP decreasing		110		mV
T _{OVP}	OVP active time	V _{IN} =5→10V			1	μs
Current Limit Programming (ILIM)						
V _{LIM}	Current limit pin voltage reference	Use current limit		0.6		V
T _{OC}	Overcurrent detection time	V _{IN} =5V, Overcurrent		300		μS
Current Limit	I _{LIMIT}	R _{LIM} = 150kΩ		0.5		A
		R _{LIM} = 62kΩ		0.99		A
		R _{LIM} = 27kΩ		1.99		A
		R _{LIM} = 18kΩ		2.88		A
Output status flag (ACKB) : Active Low						
R _{on_ACKB}	ACKB Pull-Down Resistance	Device not in fault condition, V _{IN} =5V		40		Ω
I _{Leak_ACKB}	ACKB Input Leakage Current	fault condition, V _{IN} =7V			1	uA
Over-Temperature-Protection (OTP)						
T _{OTP}	Thermal Shutdown Threshold			150		°C
T _{OTP_HYS}	Thermal Shutdown Hysteresis			20		°C



Typical Operating Characteristics

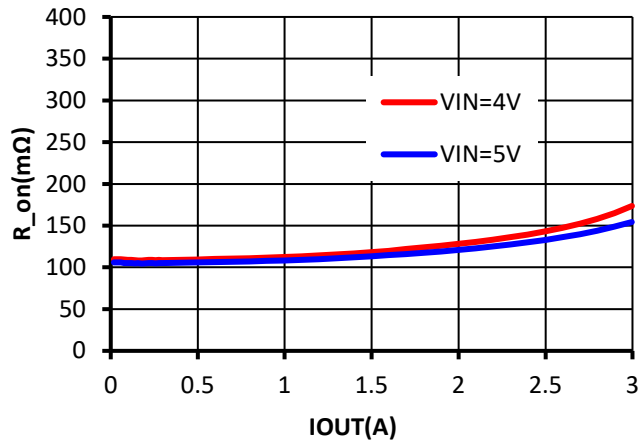

Figure1. Turn-on internal resistance vs Different load.

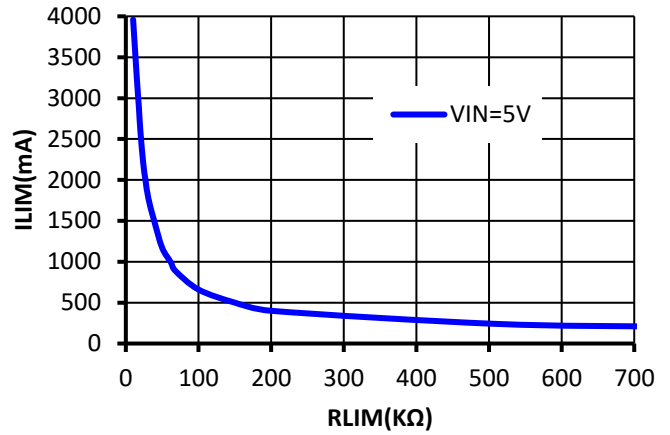

Figure2. Current limit vs Different Resistance.

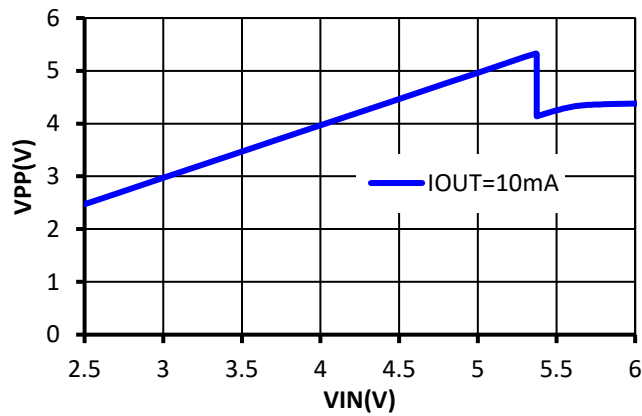

Figure3. VPP voltage source vs Different Input.

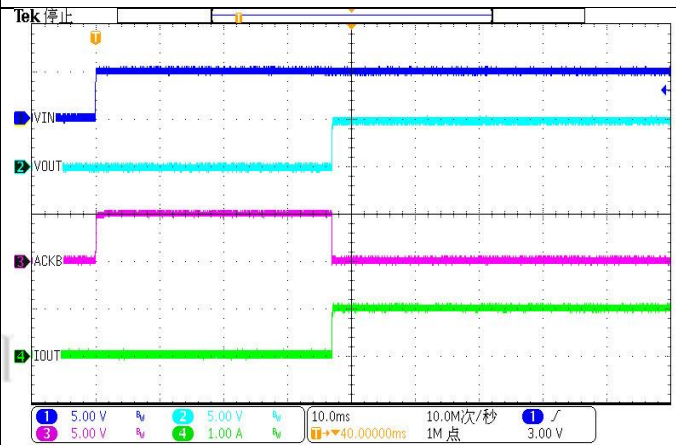

Figure4. Turn-on With VIN @VIN=5V, Load=5Ω

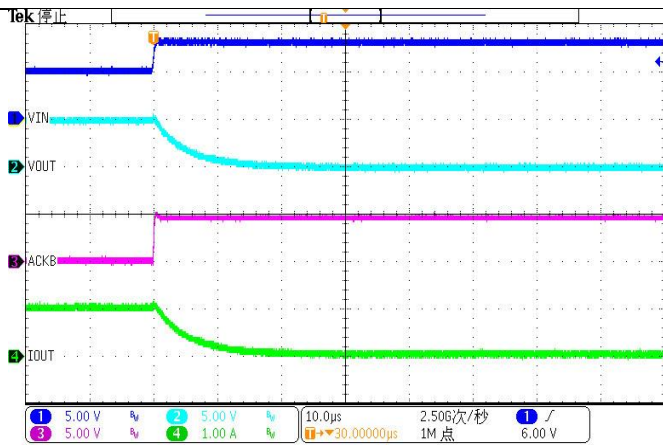

Figure5. OVP Turn-on @VIN=5V->8V, Load=5Ω

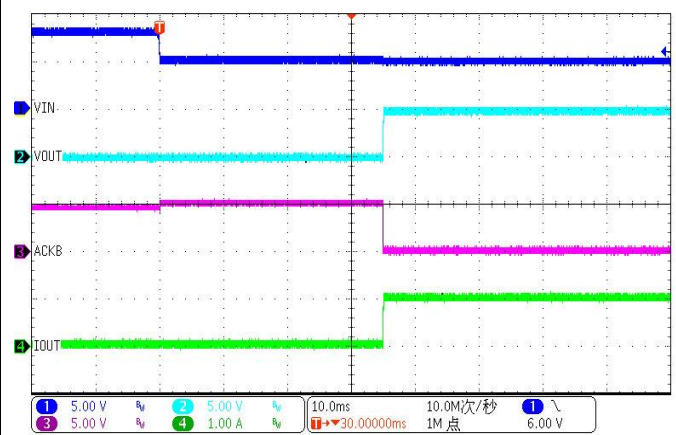

Figure6. OVP Recover @VIN=8V->5V, Load=5Ω



Application Information

The LP5303A device is a single-channel smart switch. The device integrates fault reporting and high-precision current detection functions, including thermal shutdown, current limit, transient overvoltage protection, etc., to achieve load control and protection. The adjustable current limiting function greatly improves the system reliability. The LP5303A device uses an open-drain structure to implement digital fault reporting. When a fault occurs, the device pulls ACKB to GND. An external pull-up resistor is required to connect to the chip's internal voltage regulator source VPP or use an external 3.3V or 5V power supply to match the microcontroller power level. The ILIM pin allows the current limit value to be set through a resistor of reasonable resistance. When an overcurrent occurs, the device improves system reliability by effectively clamping the inrush current. In addition, the current limit of the device can be flexibly selected according to the usage scenario. In application scenarios where the current limit function is not required, the ILIM pin is grounded, and the chip disables the current limit function. The chip has a fixed start delay time during soft start or fault restart to ensure the stable operation of the system. Provide DFN-8 packaged products.

Current Limit Programming

Connecting resistors with different resistance values to the ground through the LIM pin can set the current peak value through the chip. The general current limit setting range is about 0.3A~3A. When the current limit function is enabled, the recommended range of external connectable resistors is about 15K. ~700K, if the current limit function is not used, just leave the LIM pin floating or ground it. The relationship between the current limit and the external resistance setting is similar to that shown in Figure 2. The external setting

resistance is as close as possible to the LIM and ground pins to avoid the influence of external power lines.

Fault Logic Flag

When a fault occurs, the device ACKB will become high impedance, generating a high logic level. Because the ACKB pin uses an internal open-drain structure to implement digital fault reporting, an external pull-up 10K resistor is required to connect to the VPP pin of the voltage regulator source provided inside the chip or use an external 3.3V or 5V power supply to match the microcontroller power level. When this function is not used, the ACKB pin can be grounded or left floating.

Internal Voltage Source

The VPP pin is a voltage stabilization source provided by the input inside the device. This pin has a certain drive capability. We generally use this pin to provide the pull-up source of the ACKB pin. It is forbidden to use this pin to provide power for other modules in the system. It is generally recommended to connect a decoupling capacitor to the VPP pin to ground to reduce the voltage fluctuation of the VPP pin..



Packaging Information

DFN-8L(0203X0.75-0.50) Unit(mm)

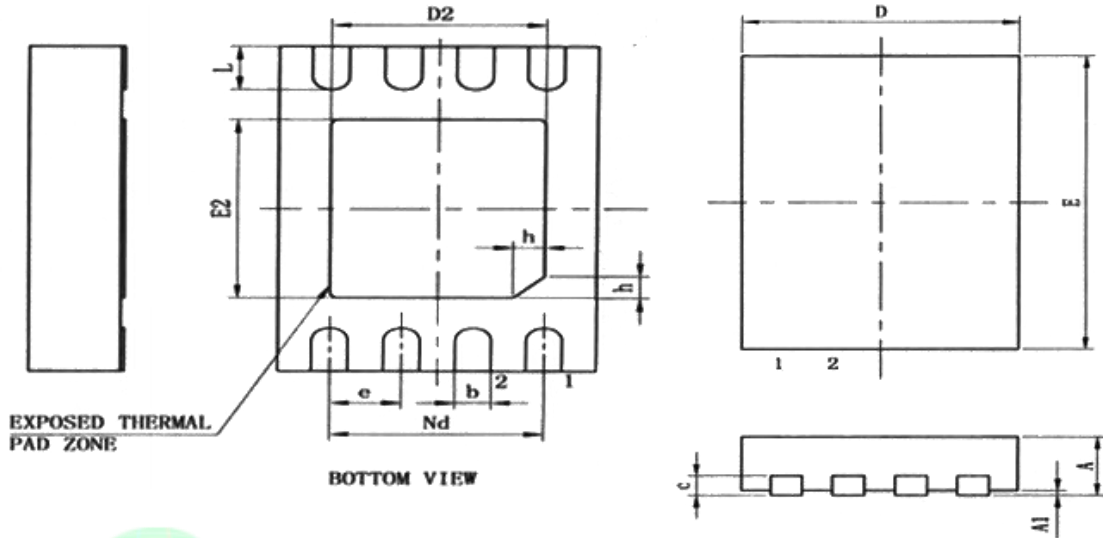

SYMBOL	MILLIMETER		
	MIN	NOM	MAX
A	0.70	0.75	0.80
A1		0.02	0.05
b	0.18	0.25	0.30
c	0.18	0.20	0.25
D	1.90	2.00	2.10
D2	1.40	1.50	1.60
e	0.50BSC		
Nd	1.50BSC		
E	2.90	3.00	3.10
E2	1.50	1.60	1.70
L	0.30	0.40	0.50
h	0.20	0.25	0.30