

1.5A Power Switch with Programmable Current Limit

General Description

The LPW5210 is an integrated power switch for self-powered and bus-powered Universal Series Bus (USB) applications. A built-in charge pump is used to drive the N-Channel MOSFET that is free of parasitic body diode to eliminate any reversed current flow across the switch when it is powered off. Its low quiescent current (30 μ A) and small package (SOT23-5) is particularly suitable in battery-powered portable equipment.

Several protection functions include soft start to limit inrush current during plug-in, current limiting at 1500mA to meet USB power requirement, and thermal shutdown to protect damage under over current conditions.

Order Information

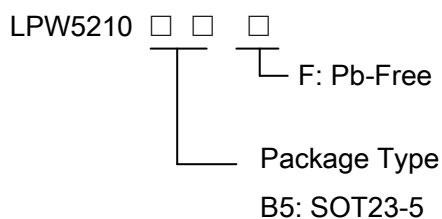

Applications

- ✧ Power Switch
- ✧ USB Device
- ✧ Battery Charger Circuits

Features

- ◆ 160m Ω Low $R_{DS(ON)}$, High-side N-MOSFET
- ◆ 1500mA Programmable current limit
- ◆ 2.5V to 6V Input Voltage
- ◆ Low Quiescent Current:30 μ A
- ◆ Soft Start Function
- ◆ Built-In Short-Circuit Protection
- ◆ Built-in Thermal Protection
- ◆ RoHS Compliant and 100% Lead (Pb)-Free

Typical Application Circuit

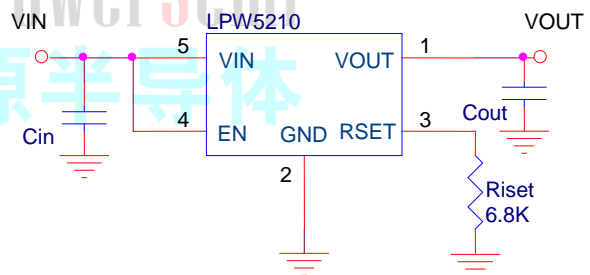

Marking Information

Device	Marking	Package	Shipping
LPW5210B5F	LPS 7WYWX	SOT23-5	3K/REEL
Marking indication: Y:Production year W:Production week X:Production batch			

Functional Pin Description

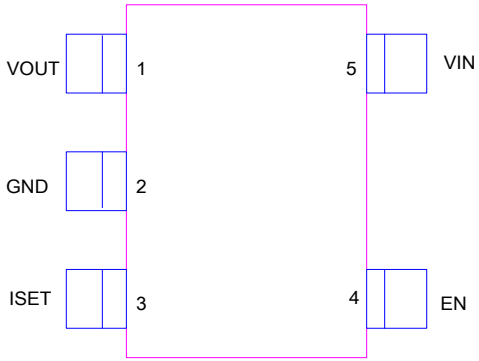
Package Type	Pin Configurations
SOT23-5	<p style="text-align: center;">Top View</p> 

Pin Description

Pin	Name	Description
1	VOUT	Output to system pin.
2	GND	Ground.
3	ISET	Connect a resistor to GND for setting current limit.
4	EN	Device Enable (active High).
5	VIN	Input pin.

Function Block Diagram

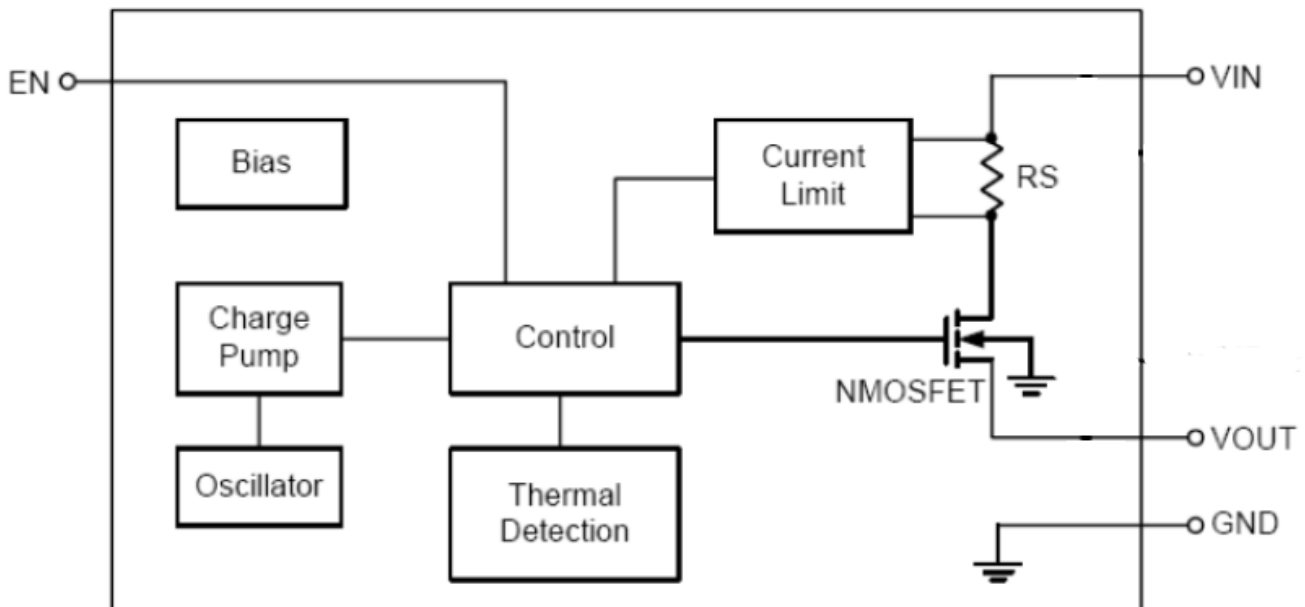

Absolute Maximum Ratings Note 1

- ◇ Input Voltage to GND ----- 6.5V
- ◇ Output Voltage to GND ----- 6.5V
- ◇ Other pin to GND ----- 6V
- ◇ Maximum Junction Temperature ----- 150°C
- ◇ Operating Ambient Temperature Range (T_A) ----- -40°C to 85°C
- ◇ Maximum Soldering Temperature (at leads, 10 sec) ----- 260°C

Note 1. Stresses beyond those listed under “Absolute Maximum Ratings” may cause permanent damage to the device. These are stress ratings only, and functional operation of the device at these or any other conditions beyond those indicated in the operational sections of the specifications is not implied. Exposure to absolute maximum rating conditions for extended periods may affect device reliability.

Thermal Information

- ◇ Maximum Power Dissipation (SOT23-5, P_D, T_A=25°C) ----- 0.45W
- ◇ Thermal Resistance (SOT23-5, θ_{JA}) ----- 250°C/W

ESD Susceptibility

- ◇ HBM(Human Body Mode) ----- 2KV
- ◇ MM(Machine Mode) ----- 200V

Electrical Characteristics

(Over recommended operating conditions unless specified otherwise, T_A=25°C)

Symbol	Parameter	Condition	Min	Typ	Max	Units
V _{IN}	Input Voltage		2.5		6	V
I _{OUT}	Output Current Limited	R _{ISSET} =10K		680		mA
		R _{ISSET} =6.8K		1000		
		R _{ISSET} =4.53K		1500		
R _{DS(ON)}	Output N-MOSFET R _{DS(ON)}			160		mΩ
I _Q	Quiescent Current	V _{IN} =3V		30		μA
I _{SHDN}	Shutdown Current	V _{EN} =GND			1	μA
V _{EN(L)}	Enable Threshold Low				0.4	V
V _{EN(H)}	Enable Threshold High		1.4			V
I _{EN}	Input High Current	V _{IN} =V _{EN} =5.0V		5		μA



Typical Operating Characteristics

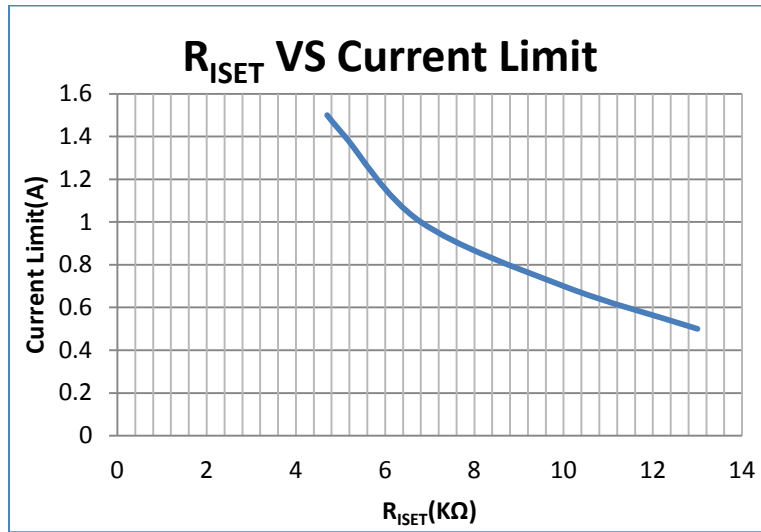

Packaging Information

SOT23-5

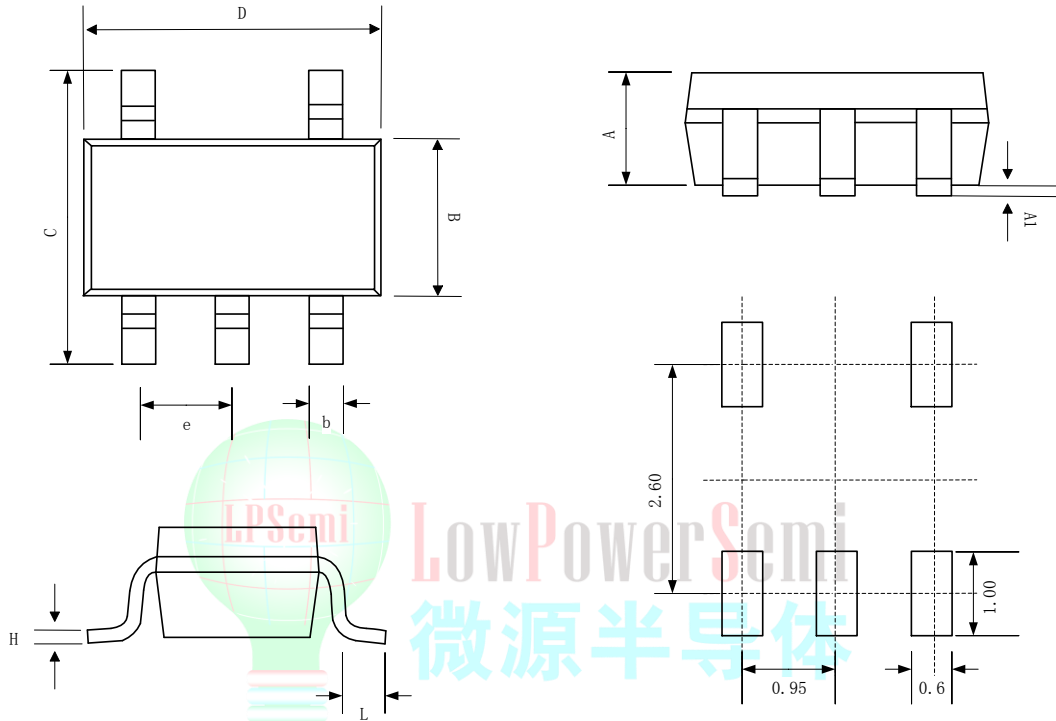

Recommended Land Pattern

SYMBOL	Dimensions In Millimeters		
	MIN	NOM	MAX
A	0.889	1.100	1.295
A1	0.000	0.050	0.152
B	1.397	1.600	1.803
b	0.28	0.35	0.559
C	2.591	2.800	3.000
D	2.692	2.920	3.120
e	0.95BSC		
H	0.080	0.152	0.254
L	0.300	0.450	0.610