

3A Smart Power Switch

General Description

The LPW5213 is an integrated power switch for self-powered and bus-powered Universal Series Bus applications. A built-in charge pump is used to drive the N-Channel MOSFET that is free of parasitic body diode to eliminate any reversed current flow across the switch when it is powered off. Its low quiescent current (30 μ A) and small package (SOT23-6) is particularly suitable in battery-powered portable equipment.

Features

- ◆ 75m Ω Low $R_{DS(ON)}$, High-side N-MOSFET
- ◆ 2.5V to 6V Input Voltage
- ◆ Low Quiescent Current:30 μ A
- ◆ Soft Start Function
- ◆ Built-In Short-Circuit Protection
- ◆ Built-in Thermal Protection
- ◆ RoHS Compliant and 100% Lead(Pb)-Free

Order Information

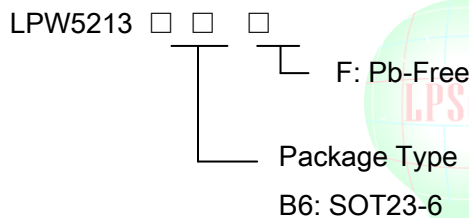

Typical Application Circuit

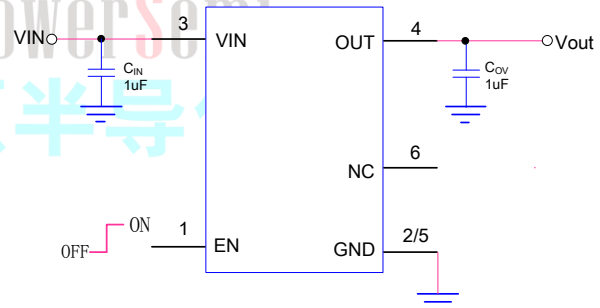

Applications

- ✧ Power Switch
- ✧ USB Device
- ✧ Battery Charger Circuits

Marking Information

Device	Marking	Package	Shipping
LPW5213B6F	LPS 3WYWX	SOT23-6	3K/REEL
Marking indication: Y:Production year W:Production week X:Production batch.			

Functional Pin Description

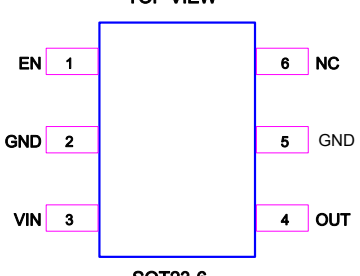
Package Type	Pin Configurations
SOT23-6	<p style="text-align: center;">TOP VIEW</p>  <p style="text-align: center;">SOT23-6</p>

Pin Description

Pin	Name	Description
1	EN	Device Enable (active High).
2/5	GND	Ground.
3	VIN	Input pin.
4	OUT	Output pin.
6	NC	No Connector.

Absolute Maximum Ratings ^{Note 1}

- ✧ Input Voltage to GND ----- 6.5V
- ✧ Output Voltage to GND ----- 6.5V
- ✧ Other pin to GND ----- 6V
- ✧ Maximum Junction Temperature ----- 150°C
- ✧ Maximum Soldering Temperature (at leads, 10 sec) ----- 260°C

Note 1. Stresses beyond those listed under “Absolute Maximum Ratings” may cause permanent damage to the device. These are stress ratings only, and functional operation of the device at these or any other conditions beyond those indicated in the operational sections of the specifications is not implied. Exposure to absolute maximum rating conditions for extended periods may affect device reliability.

Thermal Information

- ✧ Maximum Power Dissipation (P_D) ----- 0.5W
- ✧ Thermal Resistance (θ_{JA}) ----- 250°C/W

ESD Susceptibility

- ✧ HBM(Human Body Mode) ----- 2KV
- ✧ MM(Machine Mode) ----- 200V

Recommended Operating Conditions

- ✧ Ambient Temperature Range ----- -20°C to 85°C

Electrical Characteristics

(Over recommended operating conditions unless specified otherwise, $T_A=25^{\circ}\text{C}$)

Symbol	Parameter	Condition	Min	Typ	Max	Units
V_{IN}	Input Voltage		2.5		6	V
I_{OUT}	Output Current			3		A
$R_{DS(ON)}$	Output N-MOSFET $R_{DS(ON)}$			75		m Ω
I_Q	Quiescent Current	$V_{IN}=3V$		30	50	μA
I_{SHDN}	Shutdown Current	$V_{EN}=\text{GND}$			1	μA
$V_{EN(L)}$	Enable Threshold Low				0.4	V
$V_{EN(H)}$	Enable Threshold High		1.4			V
I_{EN}	Input High Current	$V_{IN}=V_{EN}=5.0V$		5		μA



Application Information

The LPW5213 are single N-Channel MOSFET high-side power switches with active-high enable input, optimized for self-powered and bus-powered Universal Serial Bus applications. The LPW5209 equipped with a charge pump circuitry to drive the internal NMOS switch; the switch's low RDS(ON) 75mΩ.

Input and Output

VIN (input) is the power source connection to the internal circuitry and the drain of the MOSFET. VOUT (output) is the source of the MOSFET. In a typical application, current flows through the switch from VIN to VOUT toward the load. If VOUT is greater than VIN, current will flow from VOUT to VIN since the MOSFET is bidirectional when on. Unlike a normal MOSFET, there is no a parasitic body diode between drain and source of the MOSFET, the LPW5213 prevents reverse current flow if VOUT being externally forced to a higher voltage than VIN when the output disabled ($V_{EN} < 0.4V$).

Chip Enable Input

The switch will be disabled when the EN pin is in a logic low condition. During this condition, the internal circuit is turned off, reducing the supply current to 0.1μA typical. The maximum guaranteed voltage for a logic low at the EN pin is 0.4V. A minimum guaranteed voltage of 1.4V at the EN pin will turn the LPW5213 back on. Floating the input may cause unpredictable operation. EN should not be allowed to go negative with respect to GND. The EN pin may be directly tied to VIN to keep the part on.

Thermal Shutdown

Thermal shutdown is employed to protect the device from damage if the die temperature exceeds approximately 150°C. If enabled, the switch automatically restarts when the die temperature falls 20°C. The output will continue to cycle on and off until the device is disabled or the fault is removed.

Packaging Information

SOT23-6

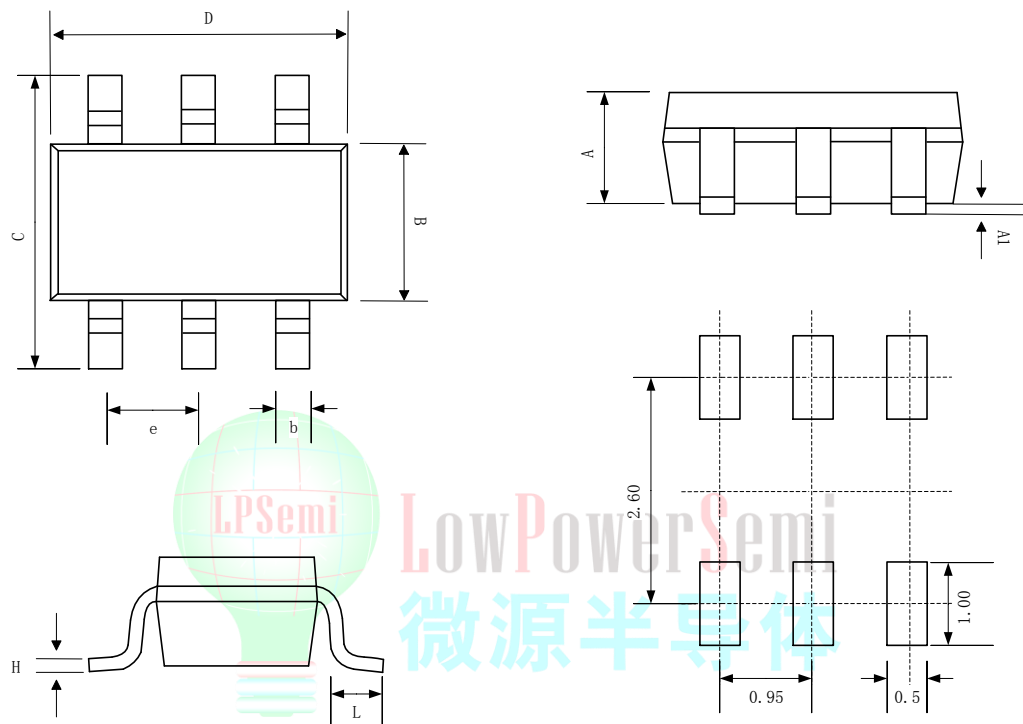

Recommended Land Pattern

SYMBOL	MILLIMETER		
	MIN	NOM	MAX
A	0.889	1.100	1.295
A1	0.000	0.050	0.152
B	1.397	1.600	1.803
b	0.28	0.35	0.559
C	2.591	2.800	3.000
D	2.692	2.920	3.120
e	0.95BSC		
H	0.080	0.152	0.254
L	0.300	0.450	0.610