



## 200KHz 36V/1.2A Synchronous Step-down Converter

### General Description

The LP6498H is a synchronous step-down regulator from a high voltage input supply. Operating with an input voltage range from 8V to 30V and 1.2A continuous output current. The converter integrates a main switch and a synchronous rectifier for high efficiency without an external schottky diode.

LP6498H requires a minimum number of readily available standard external components, over current protection and thermal shutdown, output short circuit protection.

The LP6498H converters are available in the industry standard SOP-8 and DIP-8 packages.

### Features

- ◆ Input Voltage Range: 8V to 30V
- ◆ Output Voltage: 5.1V
- ◆ 1200mA Load Current
- ◆ Up to 93% Efficiency
- ◆ 200KHz Switching Frequency
- ◆ Short Circuit Protection
- ◆ Thermal Fault Protection
- ◆ SOP-8 Package
- ◆ RoHS Compliant and 100% Lead (Pb)-Free

### Order Information

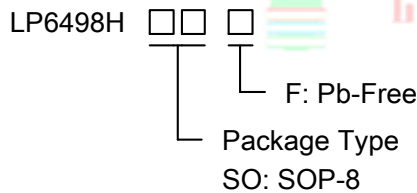

### Typical Application Circuit

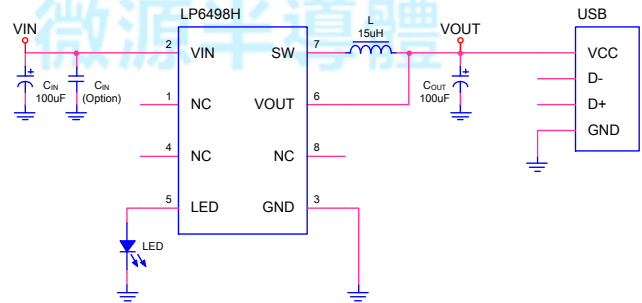

### Applications

- ✧ Car Charger / Adaptor
- ✧ Pre-Regulator for Linear Regulators
- ✧ Distributed Power Systems
- ✧ USB Dedicated Charging Ports (DCP)

### Marking Information

Device	Marking	Package	Shipping
LP6498HSOF	LPS LP6498H YWX	SOP-8	4K/REEL
Marking indication: Y:Production year W:Production week X: Series Number			

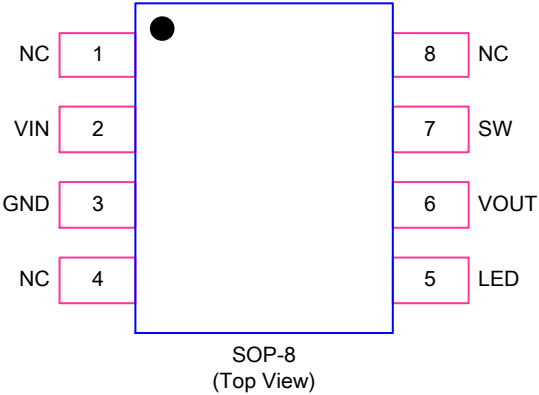

### Functional Pin Description

Package Type	Pin Configurations
SOP-8	 <p style="text-align: center;">SOP-8 (Top View)</p>

### Pin Description

Pin No.	Name	Description
1	NC	No Connection.
2	VIN	Voltage Supply.
3	GND	Ground.
4	NC	No Connection.
5	LED	Output Voltage Status Indicator.
6	VOUT	Feedback Input. Connection to output voltage.
7	SW	Switch Mode Connection to Inductor. This pin connects to the drains of the internal main and synchronous power MOSFET switches.
8	NC	No Connection.



### Absolute Maximum Ratings <sup>Note 1</sup>

- ◇ VIN,SW to GND ----- -0.3V to 36V
- ◇ VOUT,LED to GND ----- -0.3V to 6.5V
- ◇ Maximum Junction Temperature ----- 150°C
- ◇ Storage Temperature ----- -65°C to 165°C
- ◇ Operating Ambient Temperature Range (T<sub>A</sub>) ----- -20°C to 85°C
- ◇ Maximum Soldering Temperature (at leads, 10 sec) ----- 260°C

**Note 1.** Stresses beyond those listed under “Absolute Maximum Ratings” may cause permanent damage to the device. These are stress ratings only, and functional operation of the device at these or any other conditions beyond those indicated in the operational sections of the specifications is not implied. Exposure to absolute maximum rating conditions for extended periods may affect device reliability.

### Thermal Information

- ◇ Maximum Power Dissipation (P<sub>D</sub>, T<sub>A</sub>=25°C) ----- 1.5W
- ◇ Thermal Resistance (θ<sub>JA</sub>) ----- 80°C/W

### ESD Susceptibility

- ◇ HBM(Human Body Mode) ----- 2KV
- ◇ MM(Machine Mode) ----- 200V





## Electrical Characteristics

(The specifications which apply over the full operating temperature range, otherwise specifications are at  $T_A=25^{\circ}\text{C}$ ,  $V_{IN}=12\text{V}$ , unless otherwise noted.)

Symbol	Parameter	Condition	Min	Typ.	Max	Units
$V_{IN}$	Input Voltage		8		30	V
$V_{OUT}$	Output Voltage Range			5.1		V
$I_Q$	Quiescent Current	$I_L=0\text{mA}$		8		mA
$V_{UVLO}$	$V_{IN}$ Under Voltage Lockout Threshold			7.2		V
$V_{UV-HYS}$	UVLO Hysteresis			1		V
$I_{LIM}$	P-Channel Current Limit	$T_J=25^{\circ}\text{C}$		2.4		A
		$T_J=140^{\circ}\text{C}$		1.6		A
$R_{DS(ON)_H}$	High-Side Switch On Resistance			240		$\text{m}\Omega$
$R_{DS(ON)_L}$	Low-Side Switch On Resistance			110		$\text{m}\Omega$
$T_{HICCUP}$	Hiccup Time			6		ms
$T_{SS}$	Soft-start Time			0.8		ms
$f_{OSC}$	Oscillator Frequency			200		KHz
$I_{LED}$	LED pin output current			2.3		mA
$T_{SD}$	Over-Temperature Shutdown Threshold			160		$^{\circ}\text{C}$
$T_{SD-HYS}$	Over-Temperature Shutdown Hysteresis			20		$^{\circ}\text{C}$



## Application Information

The LP6498H is a switch-mode step-down DC-DC converter. The device operates at a fixed 200KHz switching frequency, and uses a slope compensated current mode architecture. This step-down DC-DC converter can supply up to 1.2A output current at input voltage range from 8V to 30V. It minimizes external component size and optimizes efficiency at the heavy load range. The integrated slope compensation allows the device to remain stable over a wider range of inductor values so that smaller values (15 $\mu$ H) with lower DCR can be used to achieve higher efficiency.

## Layout Guidance

When laying out the PCB board, the following layout guideline should be followed to ensure proper operation of the LP6498H:

1. The power traces, including the GND trace, the SW trace and the IN trace should be kept short, direct and wide to allow large current flow. The L connection to the SW pins should be as short as possible. Use several VIN pads when routing between layers.
2. The input capacitor ( $C_{IN}$ ) should connect as closely as possible to VIN and GND to get good power filtering.





### Packaging Information

#### SOP-8

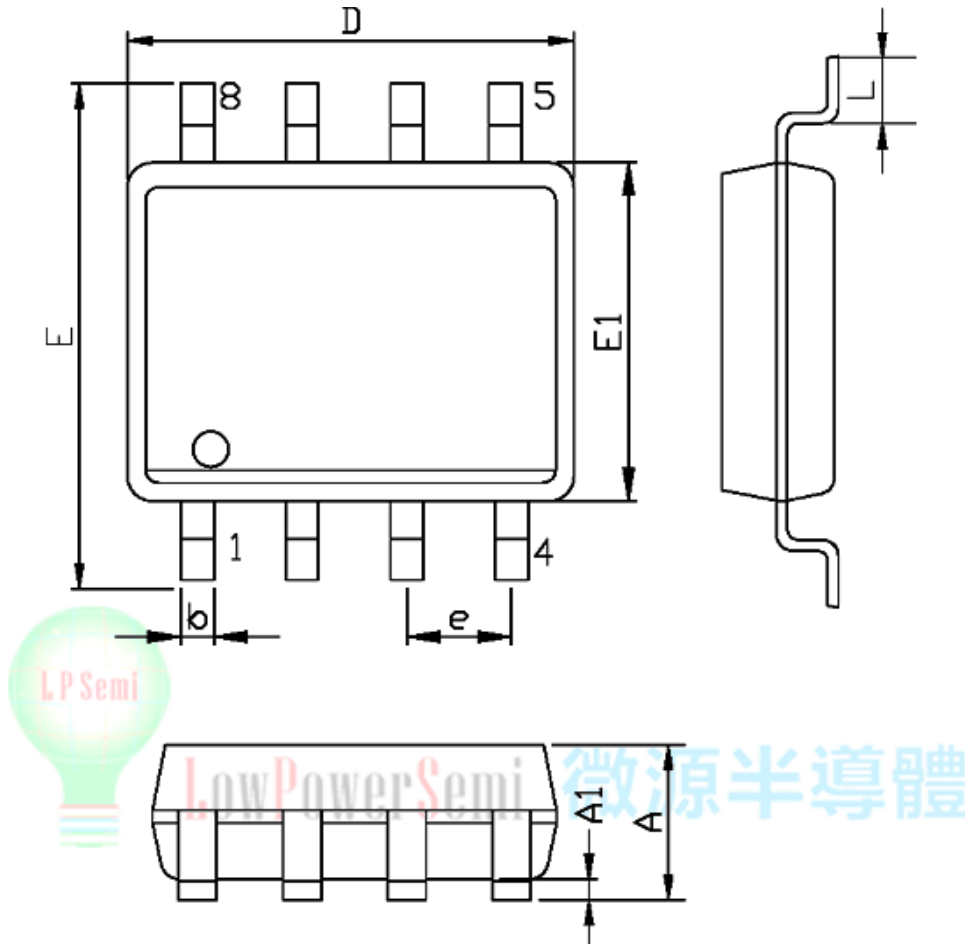

SYMBOLS	MILLIMETERS		INCHES	
	MIN.	MAX.	MIN.	MAX.
A	1.35	1.75	0.053	0.069
A1	0.10	0.25	0.004	0.010
D	4.90		0.193	
E	5.80	6.20	0.228	0.244
E1	3.90		0.153	
L	0.40	1.27	0.016	0.050
b	0.31	0.51	0.012	0.020
e	1.27		0.050	