

300mA Output, Low noise, Low-Dropout CMOS Linear Regulator

General Description

The LP3981S series low-dropout, low-power regulators offer a fast start-up and excellent line and load transient responses. A low ground current while at no load with chips enabled makes the devices attractive for battery-operate power systems. The LP3981S series also provides an active pull-down circuit to quickly discharge output load. Other features include short current limit, thermal protection and a low current consume shut-down mode.

The LP3981S is available in SOT23-5 package.

Order Information

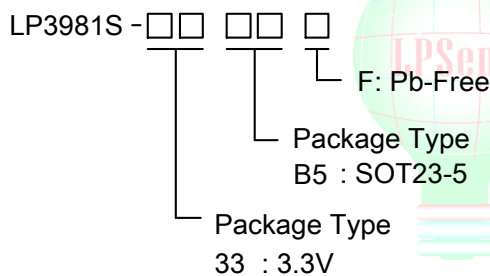

Features

- ◆ Low Dropout: 260mV @ 300mA
- ◆ 300mA Output Current, 500mA Peak Current
- ◆ High PSRR: -63dB at 1KHz
- ◆ <0.1uA Standby Current In Shutdown Mode
- ◆ TTL-Logic-Controlled Shutdown Input
- ◆ Ultra-Fast Response in Line/Load transient
- ◆ Current Limit and Thermal Shutdown Protection

Typical Application Circuit

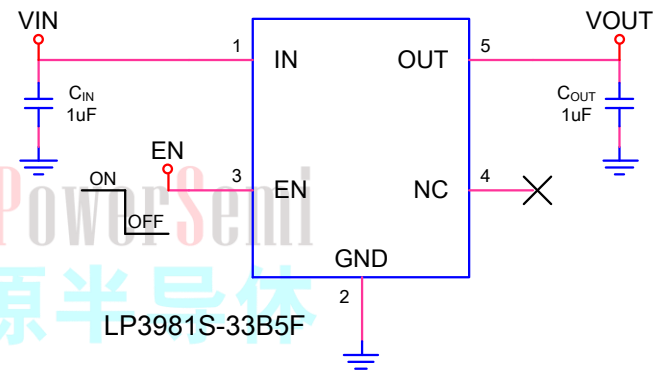

Applications

- ✧ Portable Media Players/MP3 players
- ✧ Cellular and Smart mobile phone
- ✧ LCD
- ✧ DSC Sensor
- ✧ Wireless Card

Marking Information

Device	Marking	Package	Shipping
LP3981S-33B5F	LPS 1EYWX	SOT23-5	3K/REEL
Y: Year code. W: Week code. X: series numbers			

Pin Descriptions

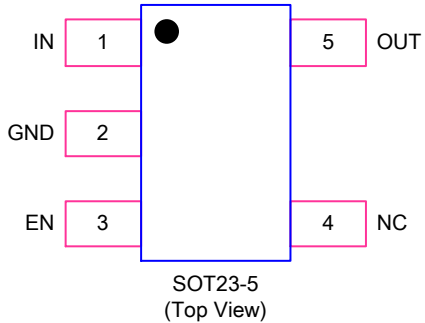
Package Type	Pin Configurations
SOT23-5	 <p style="text-align: center;">SOT23-5 (Top View)</p>

Pin	Name	Description
1	IN	Power Supply Pin.
2	GND	Ground.
3	EN	Chip Enable (Active High). Note that this pin is high impedance. There should be a pull low 100kΩ resistor connected to GND when the control signal is floating.
4	NC	NC.
5	OUT	Output Pin.

Functional Block Diagram

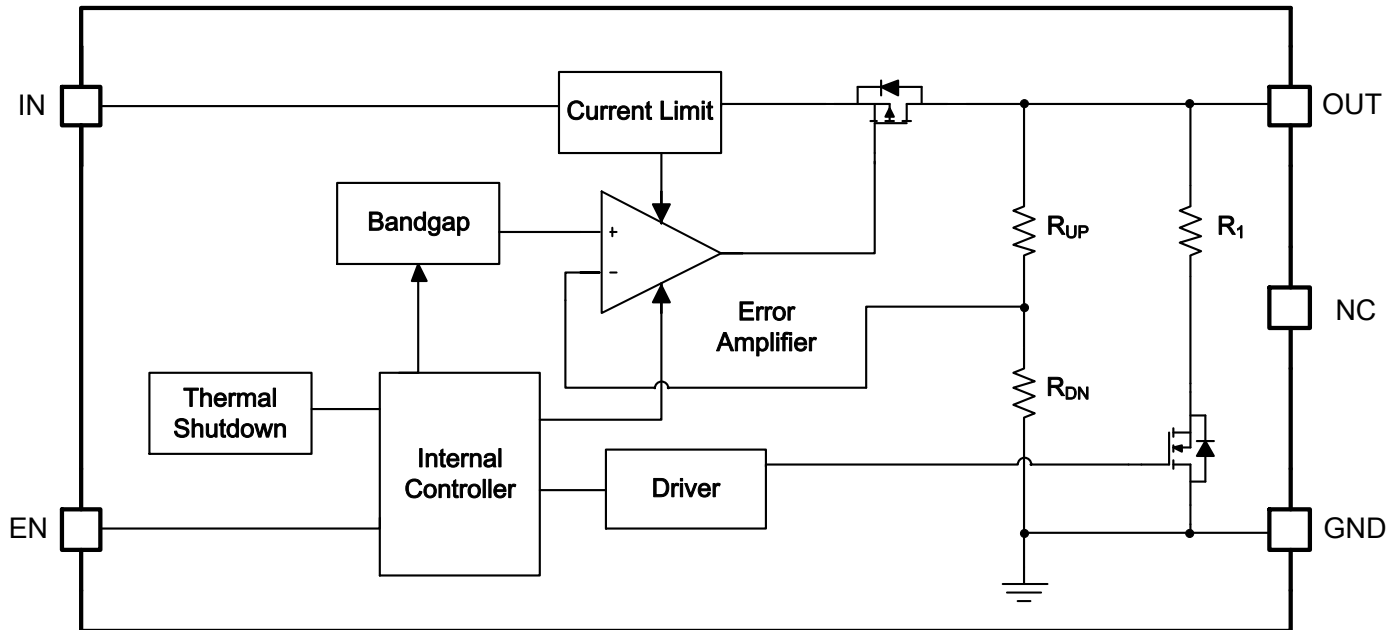

Absolute Maximum Ratings

◇ Supply Input Voltage	-----	-0.3V to 6V
◇ Other Pins Voltage	-----	-0.3V to 6V
◇ Power Dissipation, P_D @ $T_A=25^\circ\text{C}$ SOT23-5	-----	400mW
◇ Package Thermal Resistance SOT23-5, θ_{JA}	-----	250°C/W
◇ Lead Temperature (Soldering, 10 sec.)	-----	260°C
◇ Storage Temperature Range	-----	-60°C to 125°C

ESD Susceptibility

◇ HBM (Human Body Model)	-----	2KV
◇ MM(Machine-Model)	-----	200V

Recommended Operating Conditions

◇ Supply Input Voltage	-----	2.5V to 5.5V
◇ EN Input Voltage	-----	0V to 5.5V
◇ Operation Junction Temperature Range	-----	-20°C to 125°C
◇ Operation Ambient Temperature Range	-----	-40°C to 85°C

Electrical Characteristics

($V_{IN}=V_{OUT} + 1V$, $C_{IN}=C_{OUT}=1\mu F$, $T_A=25^\circ C$, unless otherwise specified)

Parameter	Symbol	Test Conditions	Min	Typ	Max	Units
Output Voltage Accuracy	ΔV_{OUT}	$I_{OUT}=1mA$	-1	--	+1	%
Output Current	I_{out}	$V_{IN}>2.8V$		300		mA
Current Limit	I_{LIM}	$R_{LOAD}=1\Omega$		550		mA
Quiescent Current	I_Q	$(V_{OUT}+1V)<V_{IN}<5.5V$, $V_{OUT}=3.3V$		58		μA
Dropout Voltage	V_{DROP}	$I_{OUT}=300mA$, $V_{OUT}=3.3V$		260		mV
Line Regulation	$\frac{\Delta V_{OUT}}{\Delta V_{IN} \times V_{OUT}}$	$V_{OUT}=3.3V$, $I_{OUT}=1mA$, $V_{IN}=4.3V$ to $5.5V$			0.5	%
Load Regulation	$\frac{\Delta V_{OUT}}{V_{OUT}}$	$V_{OUT}=3.3V$, $I_{OUT}=1mA$ to $200mA$			1	%
Standby Current	I_{STBY}	$V_{EN}=0V$, Shutdown		0.1	1	μA
EN Input Bias Current	I_{BSD}	$V_{EN}=1V$		0.6	2	μA
EN Threshold	Logic-Low Voltage	V_{IL}			0.4	V
	Logic-High Voltage	V_{IH}	1.4			V
Output Noise Voltage		10Hz to 100kHz, $I_{OUT}=200mA$ $C_{OUT}=1\mu F$		100		$\mu VRMS$
Power Supply Rejection Rate	f=1KHz	PSRR	$C_{OUT}=1\mu F$, $I_{OUT}=50mA$, $V_{OUT}=3.3V$	-63		dB
	f=10KHz			-56		dB
Thermal Shutdown Temperature	T_{SD}	$I_{OUT}=0.1mA$		160		$^\circ C$

Typical Operating Characteristics

($C_{IN}=C_{OUT}=1\mu F$, $T_A=25^\circ C$, unless otherwise specified)

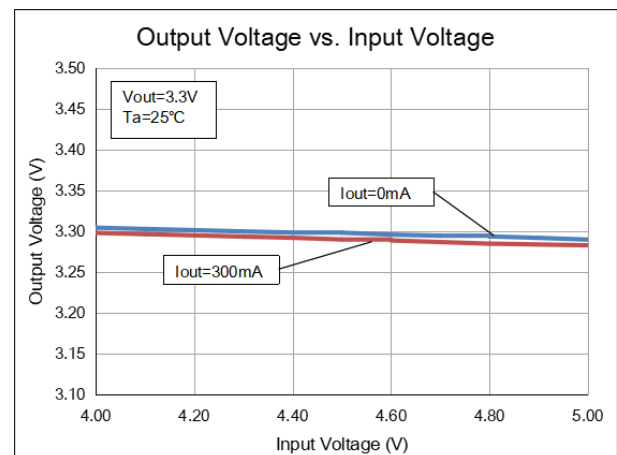
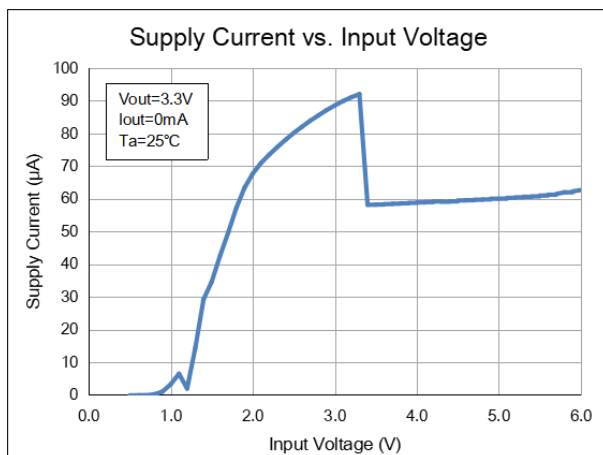

Typical Operating Characteristics

($C_{IN}=C_{OUT}=1\mu F$, $T_A=25^\circ C$, unless otherwise specified)

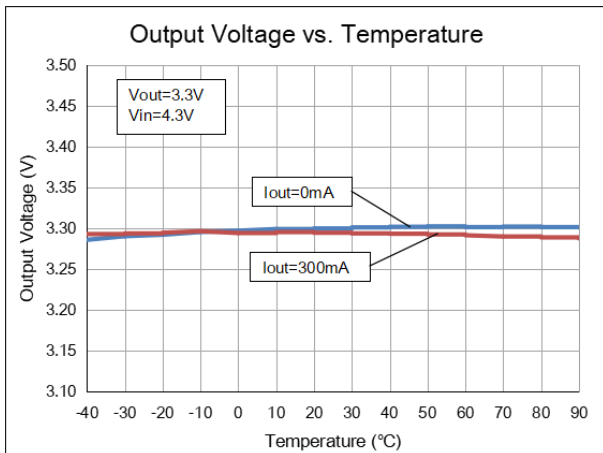
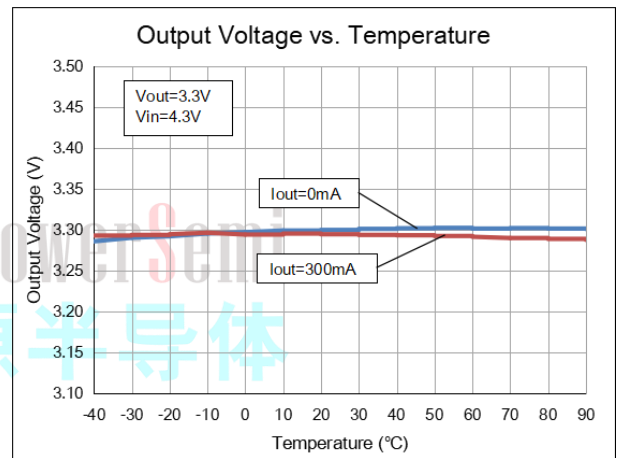
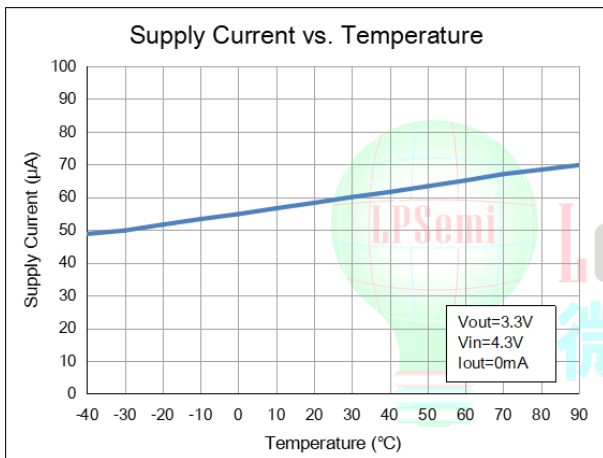
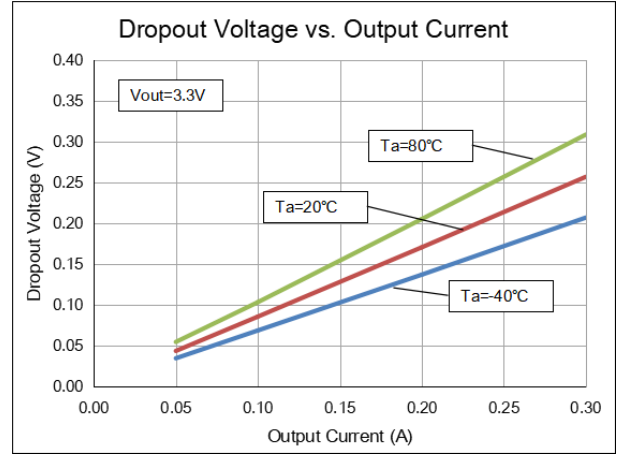
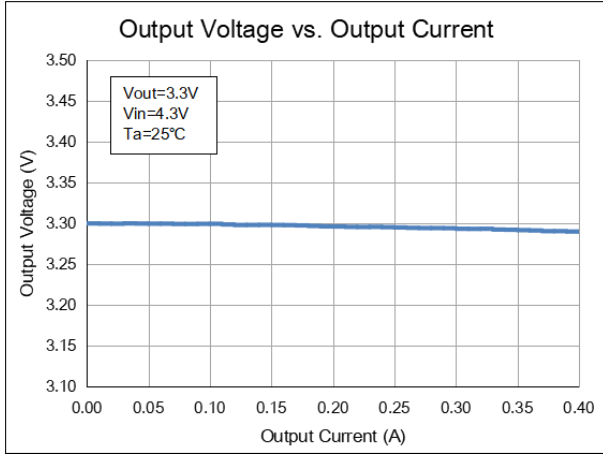

Applications Information

The LP3981S series is a low input, low quiescent current and low dropout linear regulator. Additionally, the device contains current limit, soft-start, active pull-down and under-voltage lockout circuit. The internal current limit circuitry protects the device from damage at fault condition. For example, the output of device short to GND or load current is larger than the limited current threshold of the device. During these fault condition, the device sources a fixed amount of current that depends on output voltage. And the internal soft-start circuitry helps protect the supply voltage from the inrush current. The active pull-down circuitry works at which EN pin is in a logic low level, in this case, the voltage of output will decrease.

Under-Voltage Lockout

The LP3981S use an under-voltage lockout circuit. As the input voltage lower than the UVLO threshold voltage (typically 1.5V), the device is turned off. With the input voltage reaches above the UVLO threshold voltage, the device turns the pass elements on.

Start-up Function Enable Function

The LP3981S automatically adjusts the soft-start current to protect input supply from the inrush current, it is approximately equal to the sum of load current and output capacitor charge current.

The enable pin is active high. The internal pass element is turned on when the enable pin voltage is higher than the EN logic high threshold voltage, and the pass element is turned off when the enable pin voltage is lower than the EN logic low threshold voltage. In this case, the device is in an ultralow current shutdown mode.

Active Discharge

The active pull-down circuit has internal pull-down MOSFET that connect a 120Ω resistor to GND in order to quickly discharge the load. The discharge circuit is active when the EN pin is logic low level and thermal shutdown mode.

Thermal Considerations

When the operation junction temperature exceeds T_{SD} , the OTP circuit turns the pass element off. The pass element turns on again after the junction temperature cools approximately 25°C. For continue operation, do not exceed absolute maximum operation junction temperature 125°C.

The power dissipation definition in device is :

$$P_D = (V_{IN} - V_{OUT}) \times I_{OUT} + V_{IN} \times I_Q$$

The maximum power dissipation depends on the thermal resistance of IC package, PCB layout, the rate of surroundings airflow and temperature difference between junction to ambient.

The maximum power dissipation can be calculated by following formula:

$$P_{D(MAX)} = \frac{T_{J(MAX)} - T_A}{\theta_{JA}}$$

Packaging Information

SOT23-5

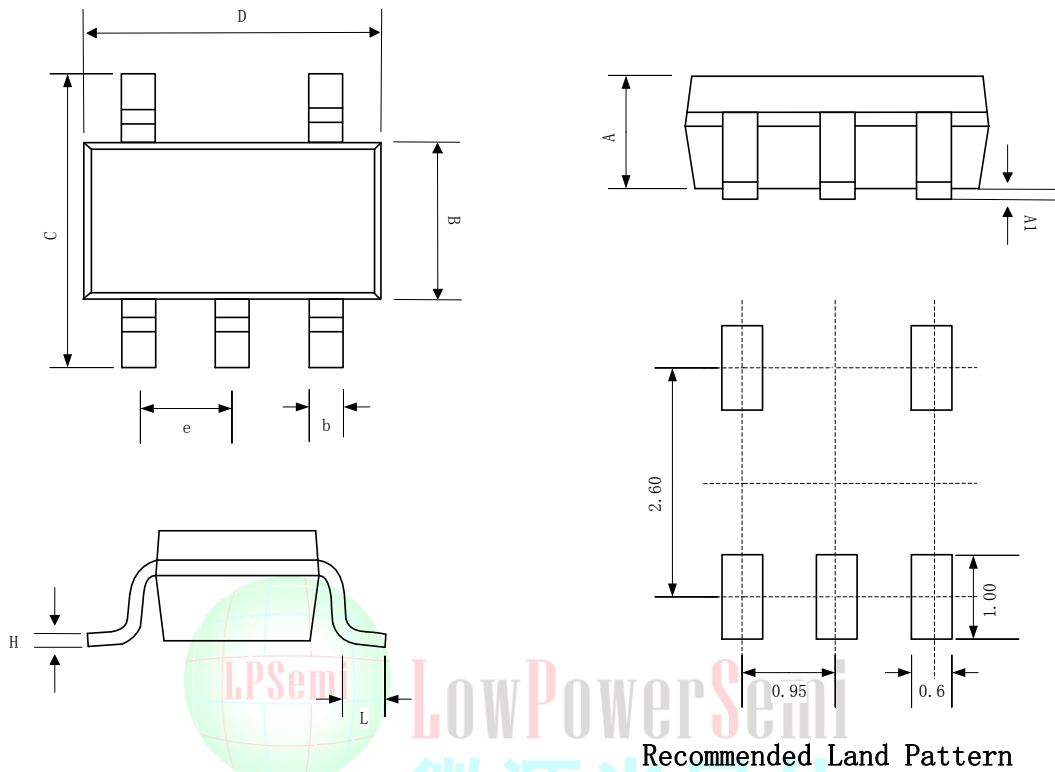

Recommended Land Pattern

SYMBOL	Dimensions In Millimeters		
	MIN	NOM	MAX
A	0.889	1.100	1.295
A1	0.000	0.050	0.152
B	1.397	1.600	1.803
b	0.28	0.35	0.559
C	2.591	2.800	3.000
D	2.692	2.920	3.120
e	0.95BSC		
H	0.080	0.152	0.254
L	0.300	0.450	0.610