



### 3.0A Power Switch with Programmable Current Limit

#### General Description

The LPW5220 is an integrated power switch for self-powered and bus-powered Universal Series Bus (USB) applications. A built-in charge pump is used to drive the N-Channel MOSFET that is free of parasitic body diode to eliminate any reversed current flow across the switch when it is powered off. Its low quiescent current (36µA) and small package (ESOP-8) is particularly suitable in battery-powered portable equipment.

Several protection functions include soft start to limit inrush current during plug-in, current limiting at 3000mA to meet USB power requirement, and thermal shutdown to protect damage under over current conditions.

#### Features

- ◆ 110mΩ Low  $R_{DS(ON)}$ , High-side N-MOSFET
- ◆ Guaranteed 3000mA Continuous Current
- ◆ 2.5V to 6V Input Voltage
- ◆ Low Quiescent Current:36µA
- ◆ Soft Start Function
- ◆ Built-In Short-Circuit Protection
- ◆ Built-in Thermal Protection
- ◆ RoHS Compliant and 100% Lead(Pb)-Free

#### Typical Application Circuit

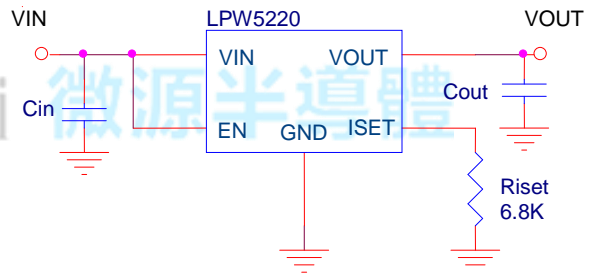

#### Order Information

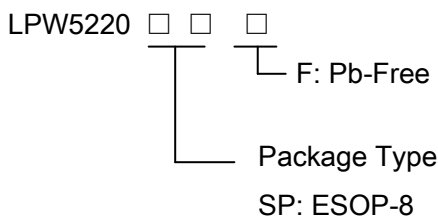

#### Applications

- ✧ Power Switch
- ✧ USB Device
- ✧ Battery Charger Circuits

#### Marking Information

Device	Marking	Package	Shipping
LPW5220SPF	LPS LPW5220 YWX	ESOP-8	2.5K/REEL
Marking indication: Y:Production year W:Production week X:Production batch			



### Functional Pin Description

Package Type	Pin Configurations
ESOP-8	

### Pin Description

Pin	Name	Description
1,3	VIN	Input pin.
2,4	EN	Chip enable with a high level voltage.
5,7	ISET	Connect a resistor to GND with program current.
6,8	VOUT	Output pin.
Pad	GND	Ground pin.

### Function Block Diagram

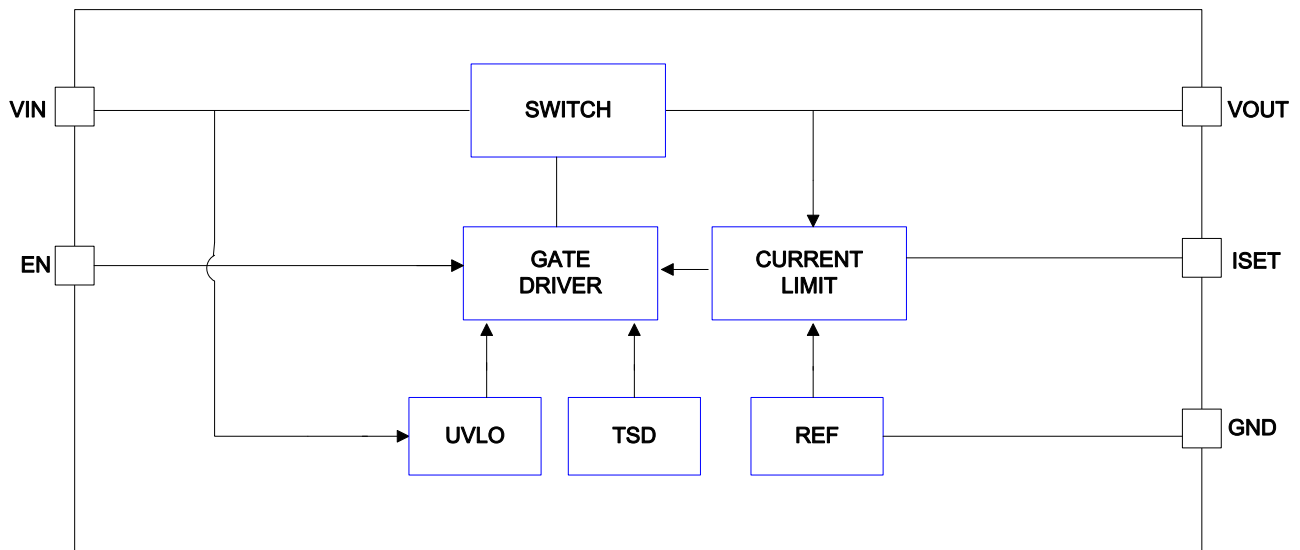



## Absolute Maximum Ratings <sup>Note 1</sup>

- ◇ Input Voltage to GND ----- 6.5V
- ◇ Output Voltage to GND ----- 6.5V
- ◇ Other pin to GND ----- 6V
- ◇ Maximum Junction Temperature ----- 125°C
- ◇ Operating Ambient Temperature Range (T<sub>A</sub>) ----- -40°C to 85°C
- ◇ Maximum Soldering Temperature (at leads, 10 sec) ----- 260°C

**Note 1.** Stresses beyond those listed under “Absolute Maximum Ratings” may cause permanent damage to the device. These are stress ratings only, and functional operation of the device at these or any other conditions beyond those indicated in the operational sections of the specifications is not implied. Exposure to absolute maximum rating conditions for extended periods may affect device reliability.

## Thermal Information

- ◇ Maximum Power Dissipation (P<sub>D</sub>, T<sub>A</sub>=25°C) ----- 1.25W
- ◇ Thermal Resistance (θ<sub>JA</sub>) ----- 46°C/W

## ESD Susceptibility

- ◇ HBM(Human Body Mode) ----- 2KV
- ◇ MM(Machine Mode) ----- 200V

## Electrical Characteristics

(Over recommended operating conditions unless specified otherwise) V<sub>IN</sub>=5.0V, EN=High, T<sub>A</sub>=25°C )

Symbol	Parameter	Condition	Min	Typ	Max	Units
V <sub>IN</sub>	Input Voltage		2.5		6	V
I <sub>OUT</sub>	Output Current Limited	R <sub>ISET</sub> =2.3KΩ		3000		mA
		R <sub>ISET</sub> =6.8KΩ		1000		
R <sub>DS(ON)</sub>	Output N-MOSFET R <sub>DS(ON)</sub>			110		mΩ
I <sub>Q</sub>	Quiescent Current	V <sub>IN</sub> =3V		36	50	μA
I <sub>SHDN</sub>	Shutdown Current	V <sub>EN</sub> =GND			1	μA
V <sub>EN(L)</sub>	Enable Threshold Low				0.4	V
V <sub>EN(H)</sub>	Enable Threshold High		1.5			V
I <sub>EN</sub>	Input High Current	V <sub>IN</sub> =V <sub>EN</sub> =5.0V		5		μA



## Typical Operating Characteristics

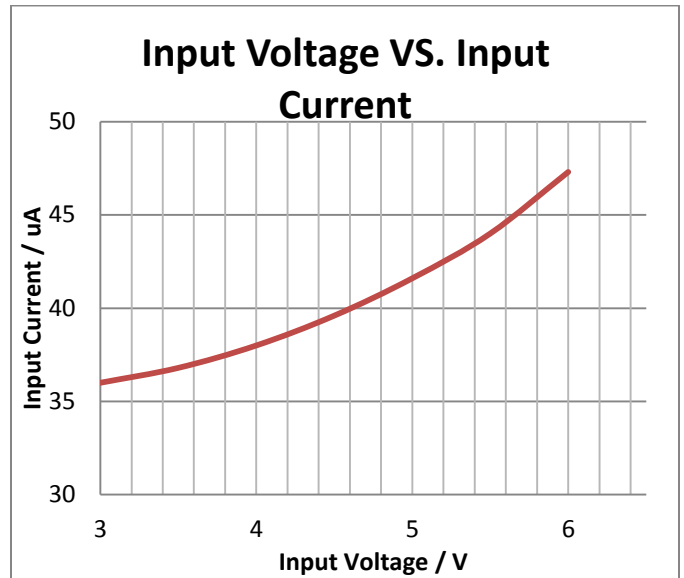
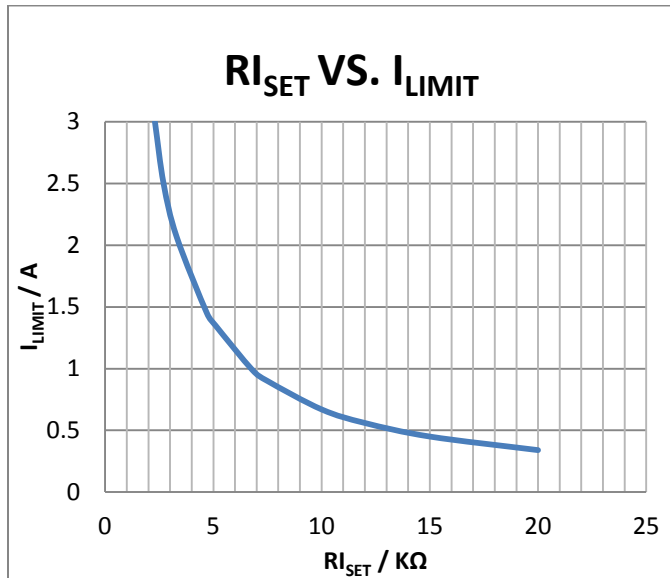



## Application Information

The LPW5220 are single N-Channel MOSFET high-side power switches with active-high enable input, optimized for self-powered and bus-powered Universal Serial Bus (USB) applications. The LPW5220 equipped with a charge pump circuitry to drive the internal N-MOS switch; the switch's low  $R_{DS(ON)}$ , 110m $\Omega$ , meets USB voltage drop requirements.

### Input and Output

VIN (input) is the power source connection to the internal circuitry and the drain of the MOSFET. VOUT (output) is the source of the MOSFET. In a typical application, current flows through the switch from VIN to VOUT toward the load. If VOUT is greater than VIN, current will flow from VOUT to VIN since the MOSFET is bidirectional when on. Unlike a normal MOSFET, there is no a parasitic body diode between drain and source of the MOSFET, the LPW5220 prevents reverse current flow if VOUT being externally forced to a higher voltage than VIN when the output disabled ( $V_{EN} < 0.4V$ ).

### Chip Enable Input

The switch will be disabled when the EN pin is in a logic low condition. During this condition, the internal circuit is turned off, reducing the supply current to 0.1 $\mu$ A typical. The maximum guaranteed voltage for a logic low at the EN pin is 0.4V. A minimum guaranteed voltage of 1.5V at the EN pin will turn the LPW5220 back on. Floating the input may cause unpredictable operation. EN should not be allowed to go negative with respect to GND. The EN pin may be directly tied to VIN to keep the part on.

### Soft Start for Hot Plug-In Applications

In order to eliminate the upstream voltage droop caused by the large inrush current during hot-plug events, the “soft-start” feature effectively isolates the power source from extremely large capacitive loads, satisfying the USB voltage droop requirements.

### Thermal Shutdown

Thermal shutdown is employed to protect the device from damage if the die temperature exceeds approximately 150°C. If enabled, the switch automatically restarts when the die temperature falls 20°C. The output signal will continue to cycle on and off until the device is disabled or the fault is removed.



### Packaging Information

### ESOP-8

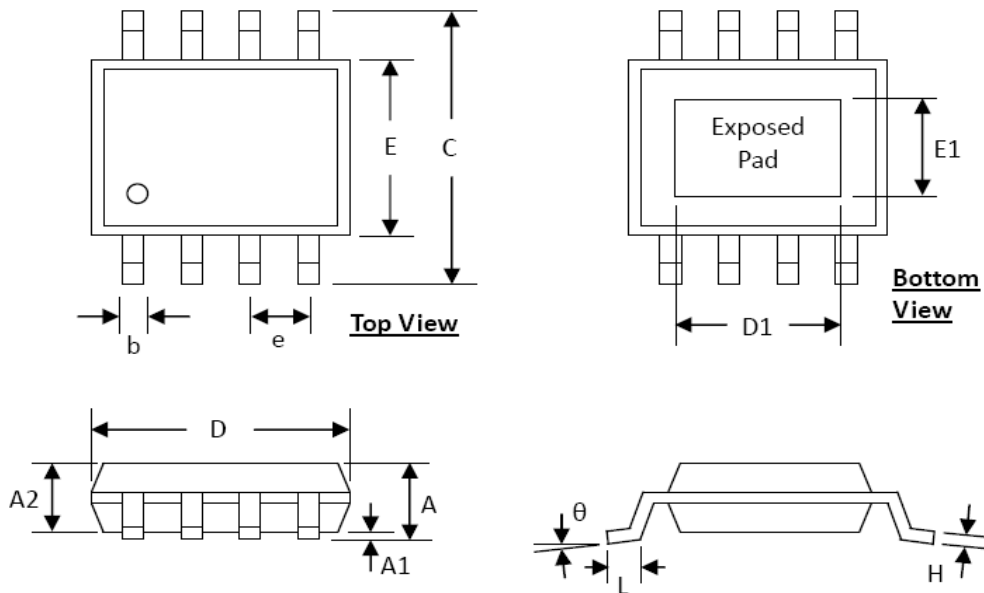

SYMBOLS	DIMENSION (MM)		DIMENSION (INCH)	
	MIN	MAX	MIN	MAX
A	1.30	1.70	0.051	0.067
A1	0.00	0.15	0.000	0.006
A2	1.25	1.52	0.049	0.060
b	0.33	0.51	0.013	0.020
C	5.80	6.20	0.228	0.244
D	4.80	5.00	0.189	0.197
D1	3.15	3.45	0.124	0.136
E	3.80	4.00	0.150	0.157
E1	2.26	2.56	0.089	0.101
e	1.27 BSC		0.050 BSC	
H	0.19	0.25	0.0075	0.0098
L	0.41	1.27	0.016	0.050
θ	0°	8°	0°	8°