



### Features

- Easy-to-use standalone single-cell charger
- High input voltage linear charger
  - Support up to 7V input voltage with 36V absolute maximum input rating
  - Maximum BAT withstand voltage up to 14V
  - Programmable up to 800mA fast charge current
  - Trickle current 10% of fast charge current
  - Termination current 10% of fast charge current
- High integration
  - Integrated reverse blocking MOSFET
  - Built-in charge current sensing
  - Internal loop compensation
  - Integrated charge status indication
- Support full charge cycle of trickle current mode, constant current (CC) mode, constant voltage (CV) mode, charge termination and automatic recharge
- BAT leakage current 30nA typical
- Protection features
  - Input under-voltage lockout (UVLO)
  - Over-voltage protection (OVP)
  - Battery reverse connection protection
  - Thermal regulation foldback
- RoHS Compliant and 100% Lead (Pb)-Free
- Package: DFN-8(2mm x 2mm)/SOT23-6

### Applications

- Wireless Speaker
- Cordless Power Tools
- Gaming Devices
- Portable Media Players
- Handheld Battery-Powered Devices
- Charging Docks and Cradles
- Power Bank
- E-Cigarettes

### General Description

The LP4069H device is a highly advanced linear charger for single cell Li-Ion and Li-Polymer batteries. The device is ideally suited for portable applications due to the small DFN-8 package and low number of external components required.

The device employs a full charge algorithm with trickle current, constant current (CC), constant voltage (CV) modes, charge termination and automatic recharge. The device supports charge current up to 800mA, programmed by an external resistor. The device can withstand an input voltage up to 36V, which can protect the charger from the accidental insertion of high voltage and hot plug-in. The device can withstand a BAT voltage up to 14V, which is suited for power battery applications. Without an input supply, the battery reverse current is only 30nA typical.

The device provides various safety features for battery charging, including input under voltage lockout (UVLO), input over-voltage protection (OVP), battery reverse connection protection, and thermal regulation foldback protection that is implemented by reducing the charge current while the junction temperature reaches 140°C.

The LP4069H is available in a DFN-8 (2mmx2mm) /SOT23-6 package.

### Order Information

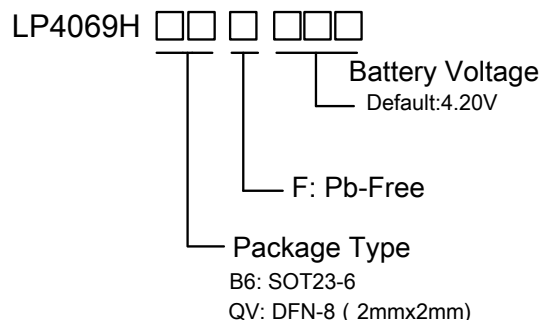



## Device Information

Part Number	Top Marking	Battery Voltage	Moisture Sensitivity Level	Package	Shipping
LP4069HQVF	LP4069 HYWX	4.20V	MSL3	DFN-8	4K/REEL
LP4069HB6F	LP4069 HYWX	4.20V	MSL3	SOT23-6	3K/REEL

Marking indication:  
Y: Production year. W: Production week. X: Series number.

## Typical Application Circuit

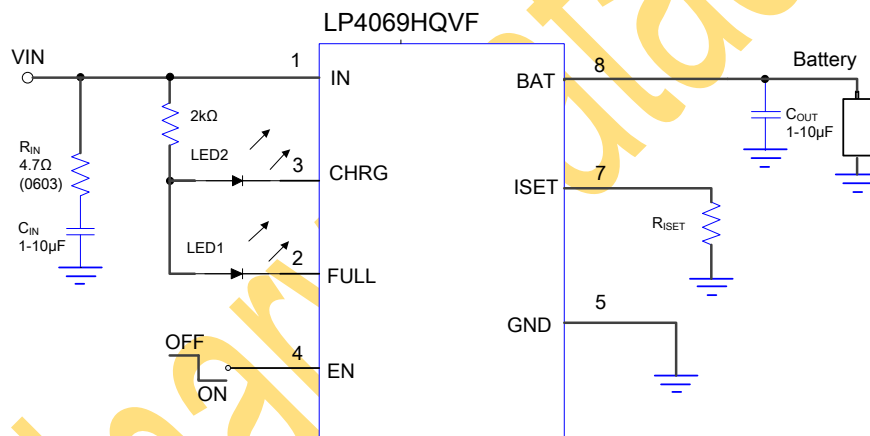



## Pin Diagram

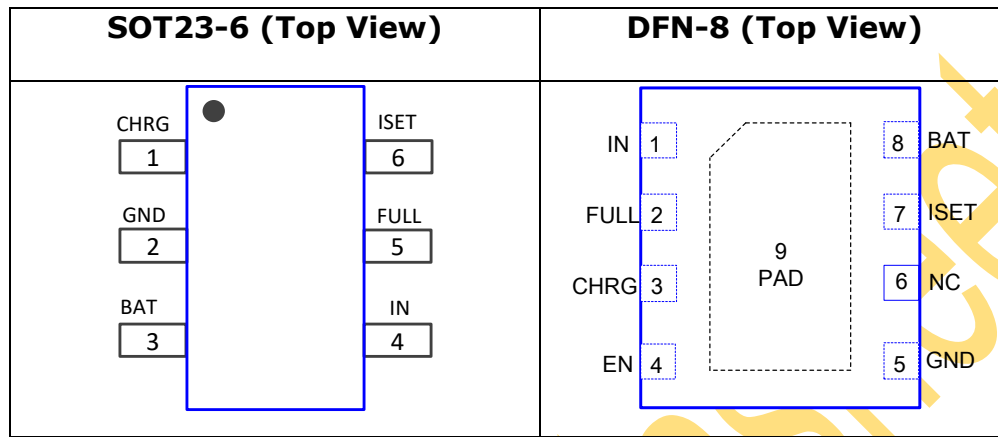

## Pin Description

Name	Package		Description
	DFN-8	SOT23-6	
IN	1	4	Positive Supply Voltage Input. Place a 4.7Ω resistor and a 1-10μF ceramic capacitor in series from IN to GND and place the capacitor as close as possible to IC.
FULL	2	5	Open-Drain Status Output. When the device is in charging state, the FULL pin is pulled high by an external pull-up resistor. When the charge cycle is completed, the pin is pulled low by an internal NMOS.
CHRG	3	1	Open-Drain Charge Status Output. When the device is in charging state, the CHRG pin is pulled low by an internal NMOS. When the charge cycle is completed, the internal NMOS turned-off, the pin could be pulled high by an external pull-up resistor.
EN	4	-	Charge Enable Input. Low active.
GND	5	2	GND. Connect to the system ground.
NC	6	-	No Connection.
ISET	7	6	Fast Charge Current Program Pin. Connect this pin with an external resistor R <sub>ISET</sub> to GND to program the fast charge current.
BAT	8	3	Battery Pin. Connect to the battery, A 1-10μF capacitor is needed typically.
PAD	9	-	Ground reference for the device that is also the thermal pad used to conduct heat from the device.



## Absolute Maximum Ratings <sup>(1)</sup>

- IN to GND ----- -0.3V to 36V
- CHRG, FULL to GND ----- -0.3V to 28V
- BAT to GND ----- -5V to 14V
- EN, ISET to GND ----- -0.3V to 6.5V
- Maximum Junction Temperature (T<sub>J</sub>) ----- 150°C
- Storage Temperature ----- -55°C to 150°C
- Maximum Soldering Temperature (at leads, 10 sec) ----- 260°C

**Note: (1)** Stresses beyond those listed under "Absolute Maximum Ratings" may cause permanent damage to the device. These are stress ratings only, and functional operation of the device at these or any other conditions beyond those indicated in the operational sections of the specifications is not implied. Exposure to absolute maximum rating conditions for extended periods may affect device reliability.

## ESD Susceptibility

- HBM (Human Body Model) ----- 2kV
- MM (Machine Model) ----- 200V

## Recommended Operating Conditions

- Input Voltage ----- 4.5V to 6V
- Maximum Charge Current ----- 800mA
- Operating Junction Temperature Range (T<sub>J</sub>) ----- -20°C to 140°C
- Operating Ambient Temperature Range (T<sub>A</sub>) ----- -20°C to 85°C



## Electrical Characteristics

(The specifications are at  $T_A=25^\circ\text{C}$ ,  $V_{IN} = 5\text{V}$ , unless otherwise noted.)

Symbol	Parameter	Condition	Min	Typ	Max	Units
<b>INPUT VOLTAGE AND CURRENT</b>						
$V_{IN}$	Input Voltage Range		4.5	5	6	V
$I_{Standby}$	Input Standby Current	Standby mode (Charge terminated) $V_{EN}=0\text{V}$		190		$\mu\text{A}$
$I_{Shutdown}$	Input Shutdown Current	$V_{EN}=5\text{V}$		27		$\mu\text{A}$
$V_{UVLO}$	Under Voltage Lockout of $V_{IN}$	$V_{IN}$ Rising	3.3	3.5	3.7	V
$V_{UVLO\_HYS}$	$V_{UVLO}$ Hysteresis	$V_{IN}$ Falling		200		mV
$V_{OVP}$	Over-Voltage Protection Threshold Voltage	$V_{IN}$ Rising	6.7	7	7.3	V
$V_{OVP\_HYS}$	OVP Hysteresis	$V_{IN}$ Falling		300		mV
<b>BAT LEAKAGE CURRENT</b>						
$I_{BAT\_Leakage}$	Battery Leakage Current	LP4069HQVF $V_{IN}$ floating, $V_{BAT}=4.2\text{V}$		0.03		$\mu\text{A}$
<b>BATTERY CHARGER</b>						
$V_{FLOAT}$	Regulated Output Voltage	LP4069HQVF	4.179	4.2	4.24	V
$I_{CC}$	Fast Charge Current	$R_{ISET}=3.4\text{k}\Omega$ , Constant Current Mode	450	500	550	mA
		$R_{ISET}=17\text{k}\Omega$ , Constant Current Mode	90	100	110	mA
$I_{TERM}$	Termination Current Threshold	$R_{ISET}=3.4\text{k}\Omega$ , Constant Voltage Mode		10%		$I_{CC}$
$I_{TRIKL}$	Trickle Charge Current	$V_{BAT}<V_{TRIKL}$ , $R_{ISET}=3.4\text{k}\Omega$		10%		$I_{CC}$
$V_{TRIKL}$	Trickle Charge Threshold Voltage	LP4069HQVF $V_{BAT}$ Rising	2.75	2.9	3.05	V
$V_{TRHYS}$	Trickle Charge Hysteresis Voltage	LP4069HQVF $V_{BAT}$ Falling		200		mV
$\Delta V_{RECHRG}$	Battery Recharge Voltage Difference Threshold ( $V_{FLOAT} - V_{RECHRG}$ )	LP4069HQVF $V_{BAT}$ Falling	100	150	200	mV



$V_{\text{Headroom}}$	$V_{\text{IN}}-V_{\text{BAT}}$ threshold Voltage	$V_{\text{BAT}}=3.7\text{V}$ , $V_{\text{IN}}$ Rising	80	115	150	mV
$V_{\text{Headroom\_HYS}}$	$V_{\text{IN}}-V_{\text{BAT}}$ threshold Voltage Hysteresis	$V_{\text{BAT}}=3.7\text{V}$ , $V_{\text{IN}}$ Falling		60		mV
$T_{\text{J\_LIMIT}}$	Junction Temperature Limit	Thermal Foldback Protection State		140		°C
$R_{\text{DS}}$	IN-BAT MOSFET on-resistance	Charge Current=500mA		750		mΩ
<b>ISET/CHARG/FULL PINs</b>						
$V_{\text{ISET\_CC}}$	ISET Pin Voltage	Constant Current Mode		1		V
$V_{\text{ISET\_TR}}$		Trickle Current Mode		0.1		V
$V_{\text{STAT}}$	STAT Pin Output Low Voltage	$I_{\text{STAT}}=5\text{mA}$			0.5	V
$I_{\text{STAT}}$	CHRG/FULL Pin Sink Current				5	mA
<b>EN PIN (LP4069HQVF)</b>						
$V_{\text{EN\_ON}}$	EN Logic-Low Voltage Threshold	EN Falling			0.4	V
$V_{\text{EN\_OFF}}$	EN Logic-High Voltage Threshold	EN Rising	1.4			V
$I_{\text{EN}}$	EN pin leakage current	$V_{\text{EN}}=5\text{V}$ or $V_{\text{EN}}=0\text{V}$	-1		1	μA



## Typical Characteristics

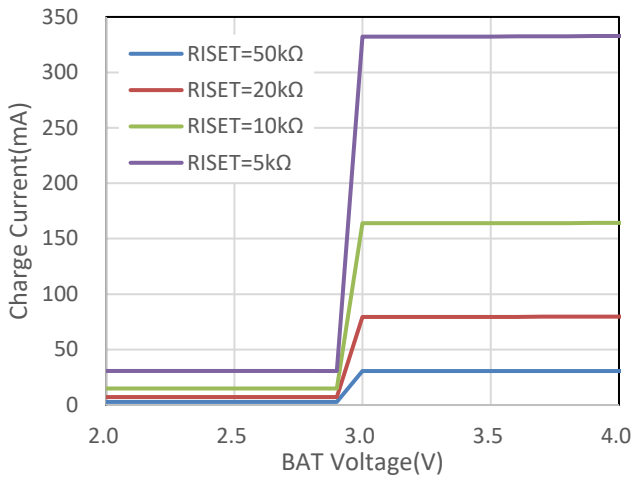

Figure 1. Charge Current vs BAT Voltage  
 $V_{IN}=5V, 25^{\circ}C$

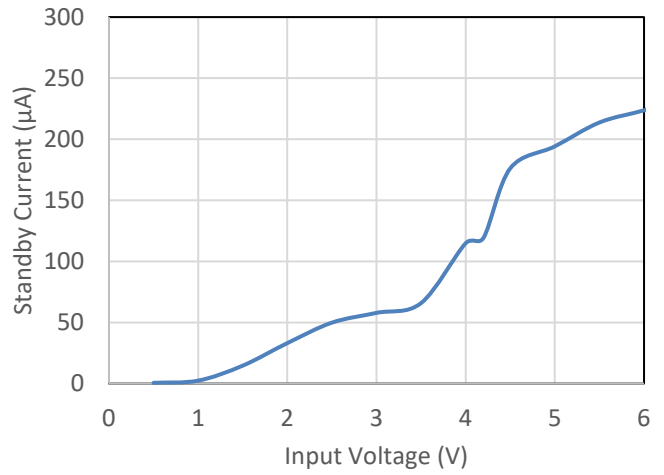

Figure 2. Input Standby current vs Input Voltage  
Charge terminated,  $25^{\circ}C$

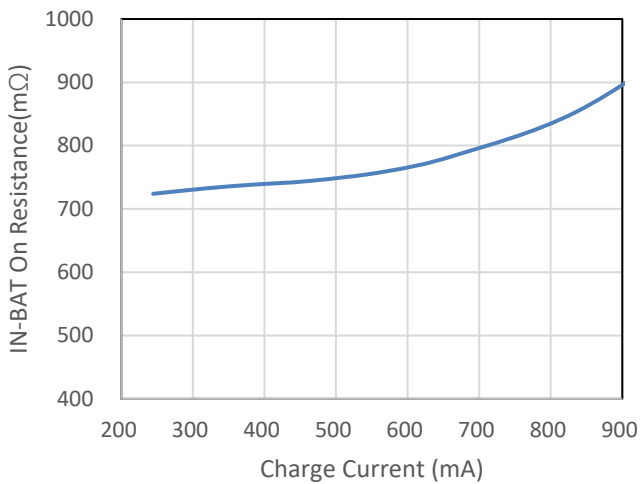

Figure 3. VIN-BAT ON-Resistance vs Charge Current  
 $V_{BAT}=3.7V, 25^{\circ}C$

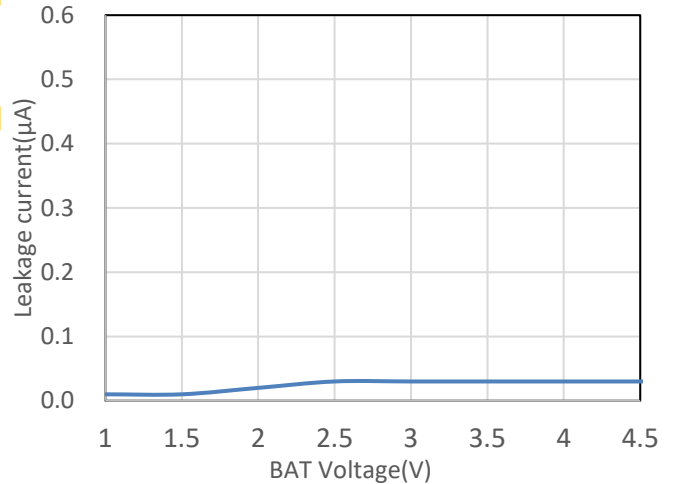

Figure 4. BAT Leakage Current vs  $V_{BAT}$   
 $V_{IN}=Floating, 25^{\circ}C$

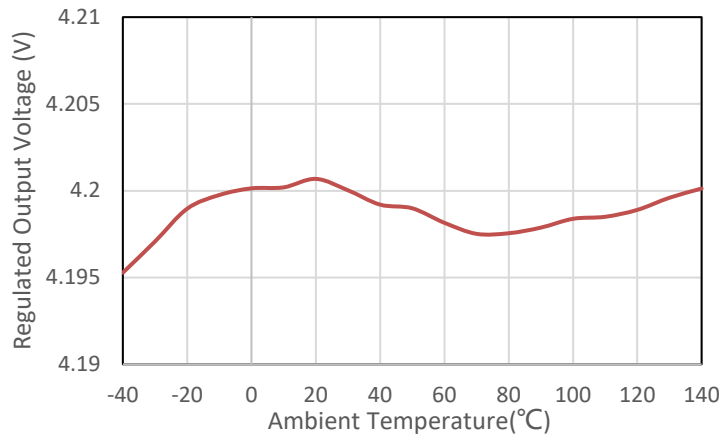
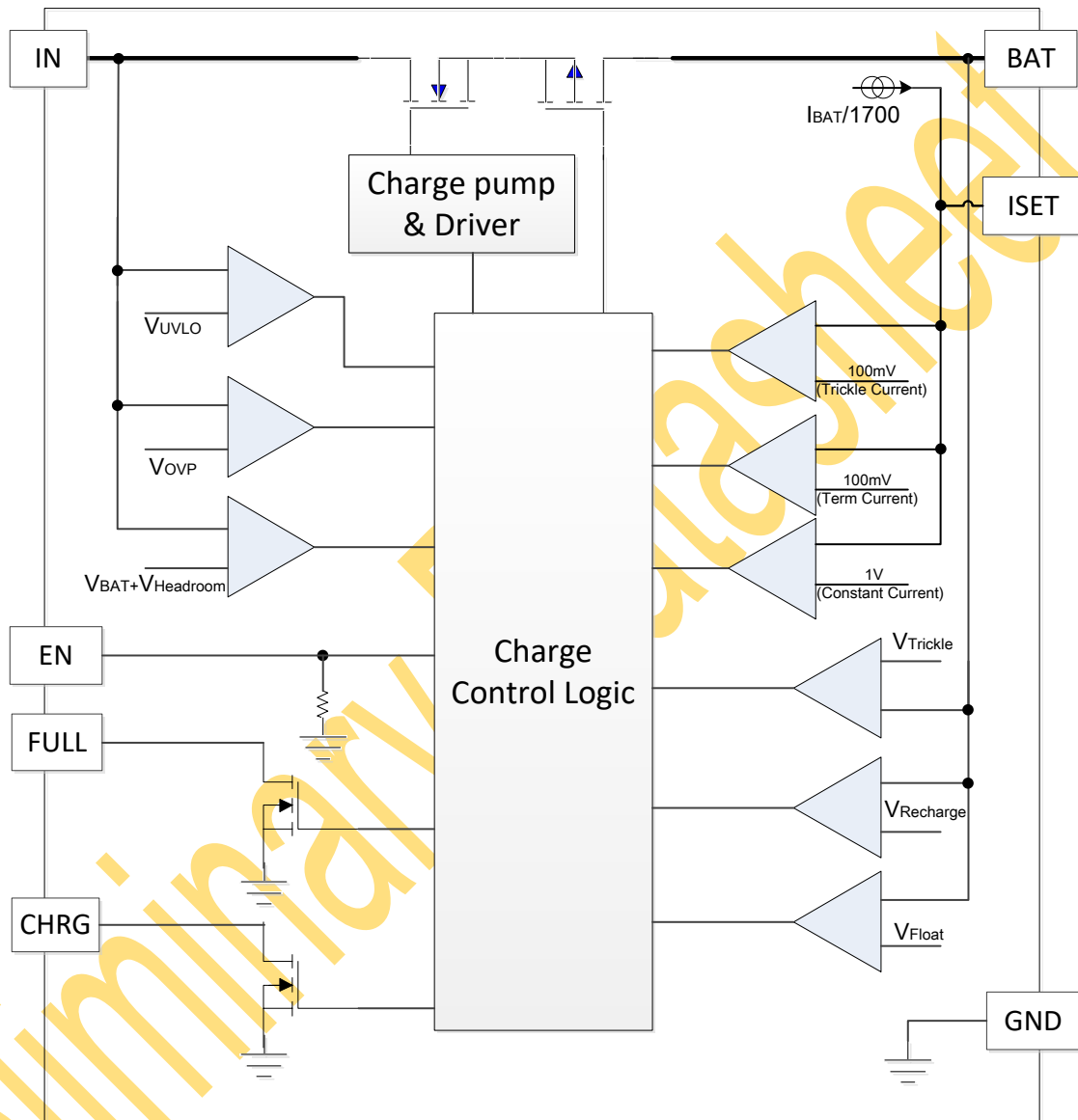

Figure 5. Regulated Output Voltage ( $V_{FLOAT}$ ) vs Ambient Temperature



## Functional Block Diagram







## Detailed Description

### Overview

The LP4069H device is a highly advanced linear charger with up to 800mA maximum charge current for single cell Li-Ion and Li-Polymer batteries. The device

charges the battery with full charge cycle: trickle current mode, constant current mode (CC), constant voltage mode (CV), charge termination and recharge. The typical charge profile can be showed as below figure.

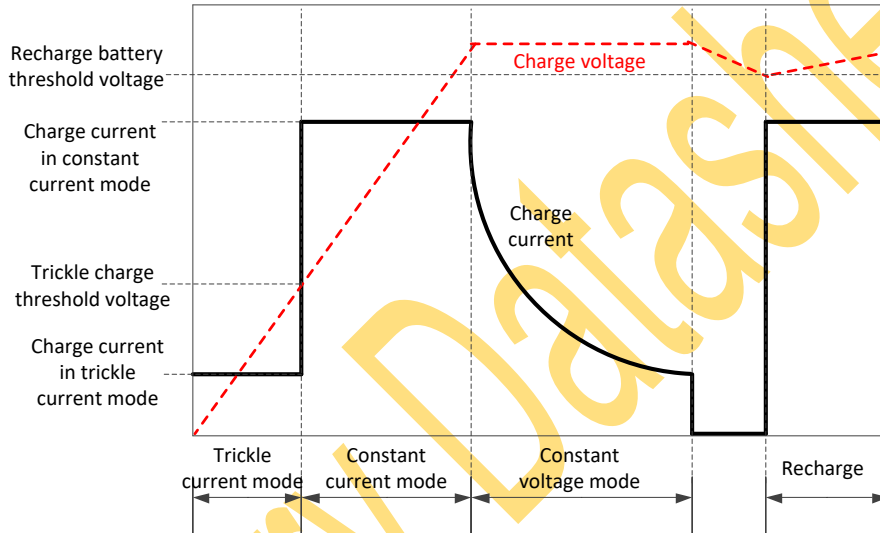

When the battery voltage is lower than Trickle Charge Threshold Voltage ( $V_{TRIKL}$ , 2.9V typical), the device charges in the trickle current mode, the charge current will be set to Trickle Charge Current ( $I_{TRIKL}$ ), which is approximately 10% of the ISET programmed Fast Charge Current ( $I_{CC}$ ) to bring the battery voltage up to a safe level for full current charging. When the battery voltage rises to  $V_{TRIKL}$ , the device enters the constant current mode, where the charge current is  $100\%I_{CC}$ . When the battery voltage approaches the Regulated Output Voltage ( $V_{FLOAT}$ ), the device goes to constant voltage mode, the charge current starts to decrease. When the charge current is lower than the Termination Current threshold ( $I_{TERM}$ ), which is  $10\%I_{CC}$ , the device will terminate the charging.

The device will automatically recharge the battery while the battery voltage drops  $\Delta V_{RECHRG}$  (150mV, typical) from the Regulated Output Voltage ( $V_{FLOAT}$ ).

### ISET Programming Fast Charge Current

The Fast Charge Current ( $I_{CC}$ ) is set by a resistor ( $R_{ISET}$ ) connecting from the ISET pin to GND. The relationship between  $I_{CC}$  and the programming resistance is established by the following formula:

$$I_{CC} = \frac{V_{ISET} \times 1700}{R_{ISET}}$$

where  $V_{ISET}=1V$  typical.

### Charge Termination and Automatic Recharge

A charge cycle will be terminated when the charge current falls to  $I_{TERM}$  ( $10\%I_{CC}$ , typical), as the battery voltage reached  $V_{FLOAT}$ . The function is implemented by monitoring the ISET pin voltage and comparing to a 100mV threshold voltage. When the ISET pin voltage falls below 100mV for longer than 1ms typically, the charging will be terminated.

Once the charge cycle is terminated, the LP4069H continuously monitors the voltage on the BAT pin by a



comparator. A new charge cycle starts when the battery voltage drops by a voltage difference  $\Delta V_{RECHRG}$  (150mV, typical) from  $V_{FLOAT}$ , which means the battery level drops to approximately 80% to 90% capacity. This ensures that the battery always keeps at or near a fully charged condition.

## Undervoltage Lockout (UVLO) and Minimum Headroom Voltage

An internal UVLO circuit monitors the input voltage and keeps the device in Shutdown mode until the input supply rises above the UVLO threshold. The UVLO circuitry has a built-in hysteresis of 200 mV. The UVLO circuit always be active.

Again, the input supply must be  $V_{Headroom}$  (115mV, typical) higher than the battery voltage before the LP4069H become operational. Whenever the input supply is below the UVLO threshold or lower than a voltage of  $V_{Headroom}$  above the VBAT pin, the LP4069H is in shutdown mode. During both conditions, the battery leakage current is only 30nA typical.

## Enable Function

The LP4069H features an enable/disable function. An input “Low” signal or floating connection on EN pin will enable the device. To ensure the device be active, the EN low voltage level must be lower than 0.4V. The device will enter the shutdown mode when the voltage on the EN pin is higher than 1.4V. If the enable function is not needed in a specific application, the EN pin could be shorted to GND or floating to keep the device continuously active.

## Charge Status Indicator (CHRG & FULL)

When the input voltage is above the  $V_{UVLO}$  and above the voltage of  $V_{BAT}+V_{Headroom}$ , but lower than  $V_{OVP}$  ( $V_{IN}<V_{OVP}$ ), CHRG pin and FULL pin have two different states: strong pull-down (~5mA) and high impedance. The strong pull-down state of CHRG implemented by an internal NMOS indicates that the LP4069H is in a charge cycle. After the charge current decreased to  $I_{TERM}$  in CV mode and then charging terminated, the CHRG pin will become high impedance, the FULL pin will become pull-down state.

Function	CHRG	FULL
Charging	Low	Hi-Z
Charge Terminated	Hi-Z	Low

## Thermal Regulation Foldback

An internal thermal regulation foldback loop reduces charge current if the junction temperature reaches a preset value of approximately 140°C to prevent further temperature rise. This function protects the device from excessive temperature and allows the user to get the limits of the power handling capability of a given circuit board without risk of damaging the device. The charge current can be set according to typical ambient temperature with the assurance that the charger will automatically reduce the current in worst-case conditions.

Charge termination function won't be active when thermal foldback regulation protection happening.



## Application Information

### Thermal Consideration

Due to the low efficiency of linear charging, the most important factors are thermal design and cost, which are a direct function of the input voltage, output charge current and thermal impedance between the battery charger and the ambient cooling air.

The power dissipation can be calculated approximately:

$$P_D = (V_{IN} - V_{BAT}) \times I_{BAT}$$

Where PD is the power dissipation,  $V_{IN}$  is the input supply voltage,  $V_{BAT}$  is the battery voltage and  $I_{BAT}$  is the charge current.

The worst-case situation is when the device has transitioned from the trickle current mode to the constant current mode. In this situation, the battery charger has to dissipate the maximum power.

In this case, with a 5V input voltage source, 800mA fast charge current, the max power dissipation could be:

$$P_{Dmax} = (5V - 2.9V) \times 0.8A = 1.68W$$

This power dissipation with the battery charger in the DFN-8 package may cause thermal regulation foldback to reduce the charge current. Then a trade-off must be made between the charge current, cost and thermal requirements of the charger.

### External Capacitors

In order to maintain good stability in the whole charge cycle, a capacitance of 1-10 $\mu$ F is recommended to bypass the BAT pin to GND. In addition, the battery and interconnections appear inductive at high frequencies. These elements are in the control feedback loop during constant voltage mode. Therefore, the bypass capacitance may be necessary to compensate for the inductive nature of the battery pack.

### ISET Resistor

In order to assure the accuracy of the charge current, better than 1% precision resistance is recommended.

### Layout Consideration

For optimum voltage regulation, place the battery pack as close as possible to the device's BAT and GND pins. This is recommended to minimize voltage drops along the high current-carrying PCB traces. If the PCB layout is used as a heat sink, adding many vias in the heat sink pad can help conduct more heat to the PCB backplane, thus reducing the maximum junction temperature. It is also recommended to place the capacitor  $C_{IN}$  and  $C_{OUT}$  as close as possible to the corresponding pins and the GND pin.



## Packaging Information

### DFN-8

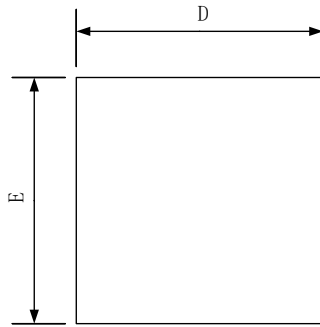

TOP VIEW

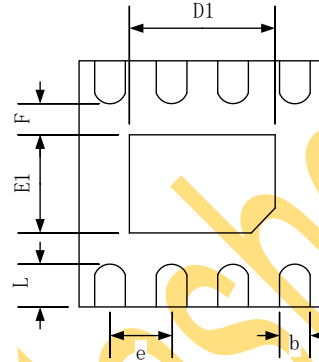

BOTTOM VIEW

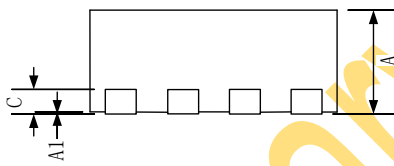

SIDE VIEW

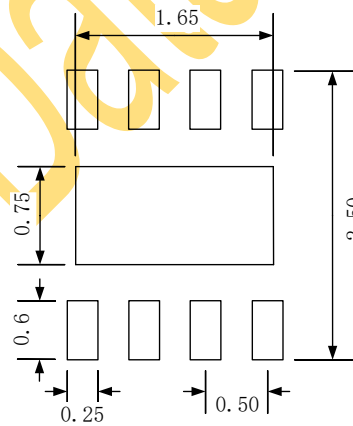

Recommended Land Pattern

SYMBOL	Dimensions In Millimeters		
	MIN	NOM	MAX
A	0.70	0.75	0.80
A1	0.00	0.02	0.05
b	0.18	0.25	0.30
c	0.20 REF		
D	1.90	2.00	2.10
D1	1.10	1.30	1.65
E	1.90	2.00	2.10
E1	0.60	0.75	0.85
e	0.50 BSC		
L	0.25	0.35	0.40
F	0.25	0.30	0.35



## SOT23-6

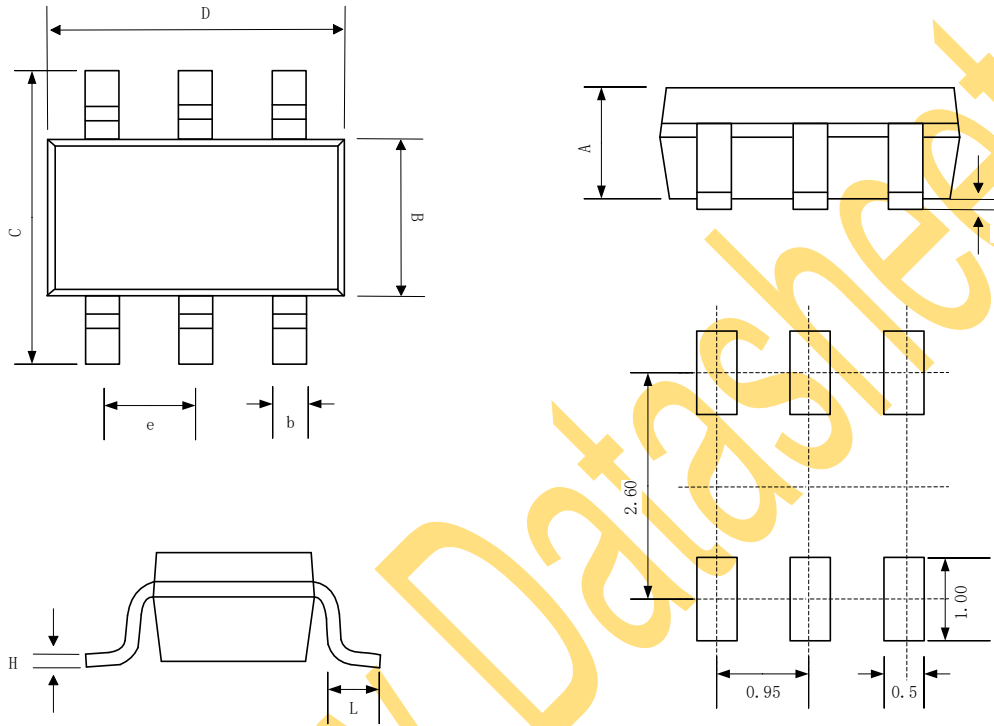

Recommended Land Pattern

SYMBOL	MILLIMETER		
	MIN	NOM	MAX
A	0.889	1.100	1.295
A1	0.000	0.050	0.152
B	1.397	1.600	1.803
b	0.28	0.35	0.559
C	2.591	2.800	3.000
D	2.692	2.920	3.120
e	0.95BSC		
H	0.080	0.152	0.254
L	0.300	0.450	0.610



## Tape and Reel Information

### DFN-8

#### REEL DIMENSIONS

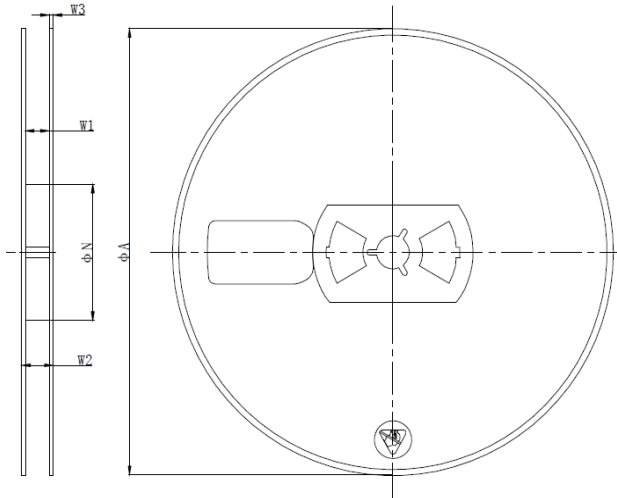

SYMBOL	Dimensions In Millimeters		
	MIN	NOM	MAX
$\phi A$	176.00	180.00	184.00
W2	10.00	12.00	14.00

#### TAPE DIMENSIONS

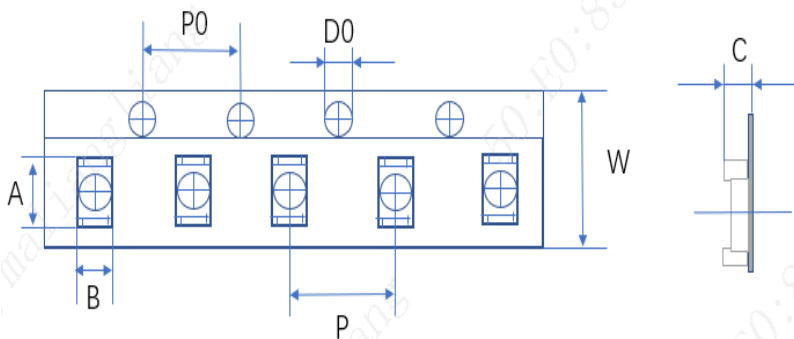

SYMBOL	Dimensions In Millimeters		
	MIN	NOM	MAX
A	2.00	2.15	2.30
B	2.00	2.15	2.30
P0	3.90	4.00	4.10
P	3.90	4.00	4.10
D0	1.40	1.50	1.60
W	7.90	8.00	8.30
C	0.80	1.00	1.20

#### PIN1 AND TAPE FEEDING DIRECTION

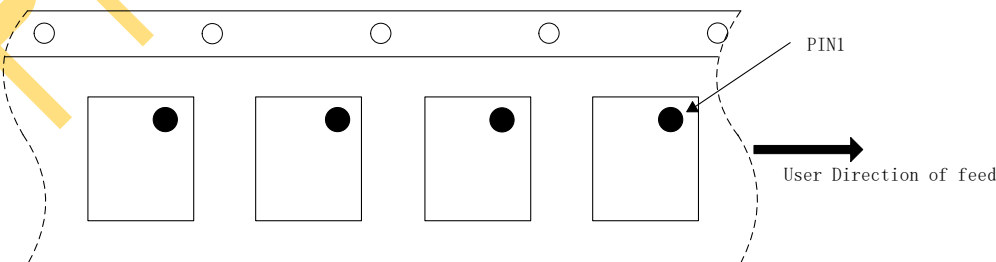



## SOT23-6

### REEL DIMENSIONS

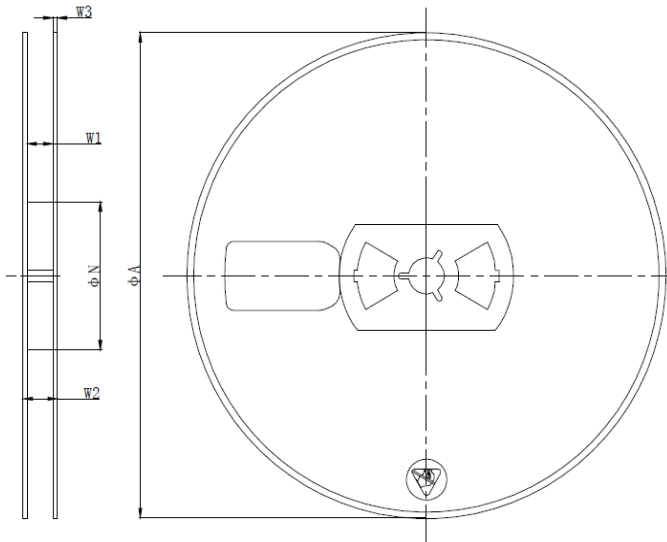

SYMBOL	Dimensions In Millimeters		
	MIN	NOM	MAX
$\phi A$	176.00	180.00	184.00
W2	10.00	12.00	14.00

### TAPE DIMENSIONS

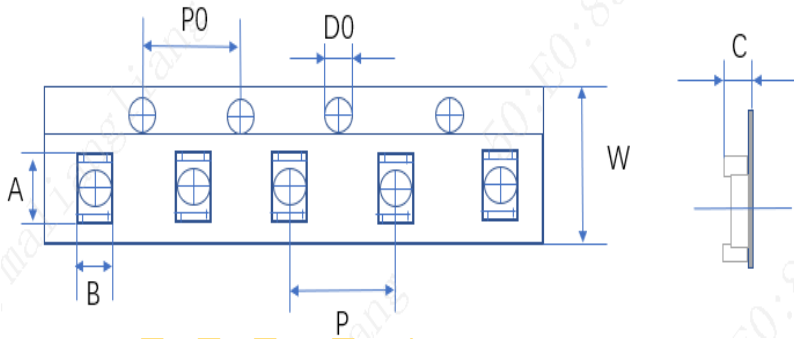

SYMBOL	Dimensions In Millimeters		
	MIN	NOM	MAX
A	3.00	3.20	3.40
B	3.06	3.26	3.46
P0	3.90	4.00	4.10
P	3.90	4.00	4.10
D0	1.35	1.50	1.55
W	7.70	8.00	8.30
C	1.20	1.40	1.60

### PIN1 AND TAPE FEEDING DIRECTION

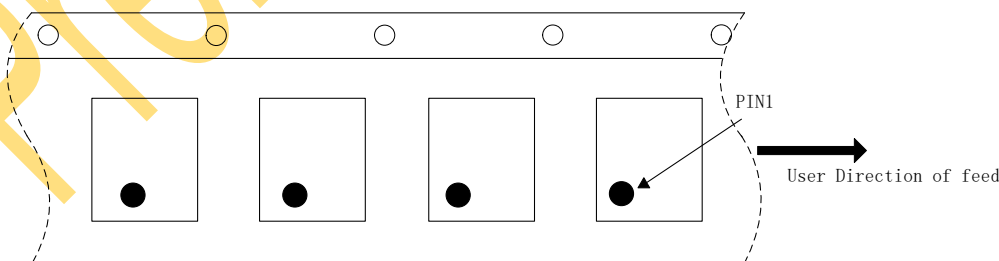



## Classification of IR Reflow Profile

Profile Feature	Sn-Pb Eutectic Assembly	Pb-Free Assembly
<b>Preheat/Soak</b>		
Temperature Min( $T_{SMIN}$ )	100°C	150°C
Temperature Max( $T_{SMAX}$ )	150°C	200°C
Time( $T_S$ ) from ( $T_{SMIN}$ to $T_{SMAX}$ )	60~120 seconds	60~120 seconds
Ramp-up rate ( $T_L$ to $T_P$ )	3°C/second max	3°C/second max
Liquidous temperature( $T_L$ )	183°C	217°C
Time( $t_L$ ) maintained above $T_L$	60~150 seconds	60~150 seconds
Peak package body temperature ( $T_P$ )	For users $T_P$ must not exceed the Classification temp in Table 1. For suppliers $T_P$ must equal or exceed the Classification temp in Table 1.	For users $T_P$ must not exceed the Classification temp in Table 2. For suppliers $T_P$ must equal or exceed the Classification temp in Table 2.
Time( $t_P$ )* within 5°C of the specified classification temperature( $T_C$ ), see Figure1	20* seconds	30* seconds
Ramp-down rate ( $T_P$ to $T_L$ )	6°C/second max	6°C/second max
Time 25°C to peak temperature	6 minutes max	8minutes max
* Tolerance for peak profile temperature ( $T_P$ ) is defined as a supplier minimum and a user maximum.		

Table 1 Sn-Pb Eutectic Process - Classification Temperatures ( $T_C$ )

Package Thickness	Volume mm <sup>3</sup> <350	Volume mm <sup>3</sup> ≥350
<2.5mm	235°C	220°C
≥2.5mm	220°C	220°C

Table 2 Pb-Free Process - Classification Temperatures ( $T_C$ )

Package Thickness	Volume mm <sup>3</sup> <350	Volume mm <sup>3</sup> 350~2000	Volume mm <sup>3</sup> ≥350
<1.6mm	260°C	260°C	260°C
1.6mm~2.5mm	260°C	250°C	245°C
>2.5mm	250°C	245°C	245°C



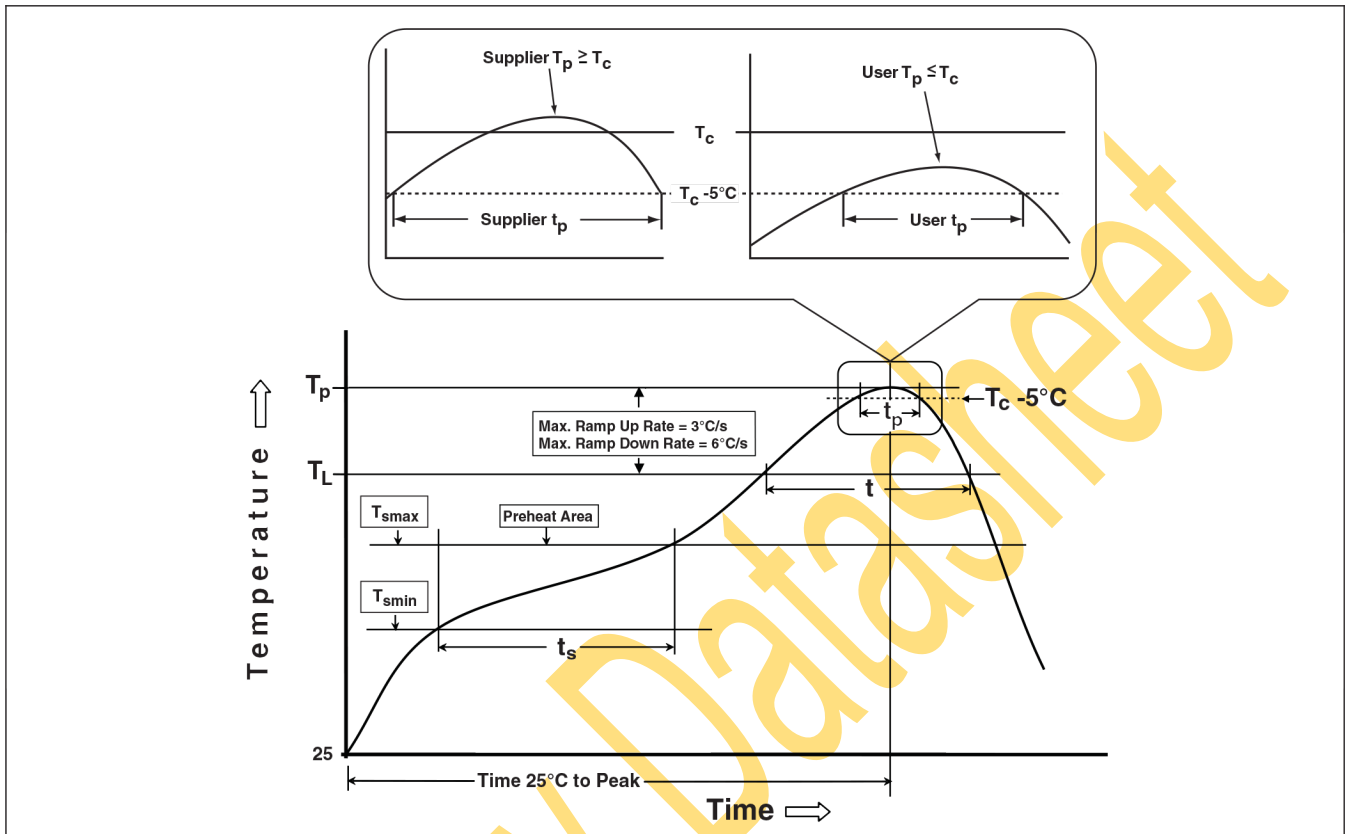

Figure1 Classification Profile (Not to scale)

Products conform to “JEDEC J-STD-020C” standards;

Products shipped conform to “RoHS” standards;

Moisture Sensitivity Level: MSL3 (CONDITION:  $\leq 30\text{ }^\circ\text{C}/60\%\text{RH}$ 、Time control:168 hours) ;