

Over Voltage and Over Current Protection IC

General Description

The LP5306 is a highly integrated circuits, it used to protect low voltage system from abnormal high input voltage. The IC continuously check the input voltage, the input current, and the battery voltage. When the protection status is occur, the power MOS will turn off at the same time. The LP5306 is safety devices to ensure worked against accidents.

In case of the input voltage exceeds a OVP threshold voltage level, the power MOS will turn off within 1 μ s. The current limit can be adjustable by external resistor between ISET and GND. And the current is also limited to prevent charging the battery with an excessive current. The LP5306 also monitors the Li-ion battery voltage, when the battery voltage exceeds 4.35V, the IC will turn off the MOS.

Other features include over temperature protection and under-voltage lockout (UVLO). The LP5306 is available in a space saving DFN-8 package.

Features

- ◆ Withstand High Input Voltage Up to 26V
- ◆ Adjustable Over Current Protection
- ◆ Input Over Voltage Protection
- ◆ Battery Over Voltage Protection
- ◆ High Accuracy Protection Thresholds
- ◆ Fault Signal Output
- ◆ Enable Control
- ◆ Under Voltage Lockout
- ◆ Output Short-Circuit Protection
- ◆ Over-Temperature Protection
- ◆ Available in DFN-8
- ◆ RoHS Compliant and Halogen Free

Applications

- ◆ Cell Phones
- ◆ Digital Cameras
- ◆ Portable Instruments

Order Information

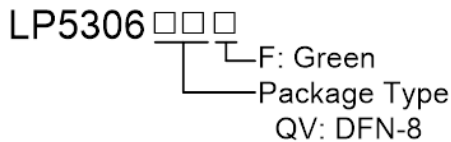

Marking Information

Device	Marking	Package	Shipping
LP5306	LPS LP5306 YWX	DFN-8	4K/REEL
Y is year code. W is week code. XXX is series number.			

Typical Application Circuit

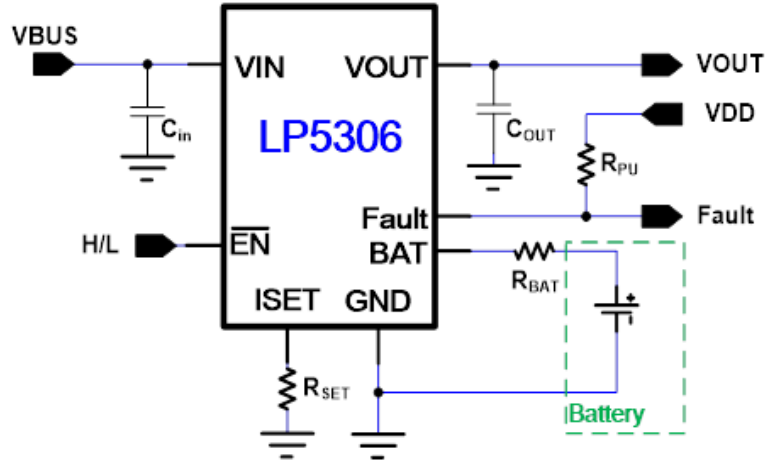

Figure 1. Typical Application Circuit of LP5306 .

Pin Configuration

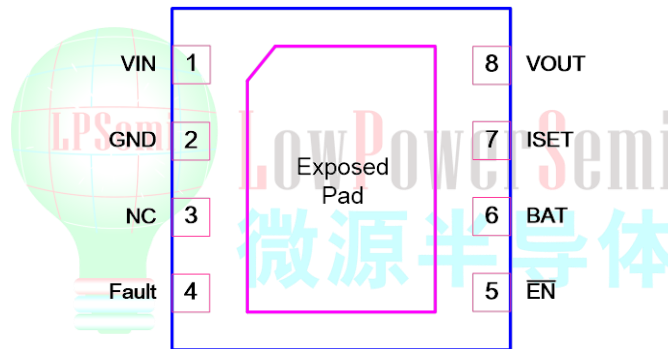

Figure 2. Package Top View



Function Block Diagram

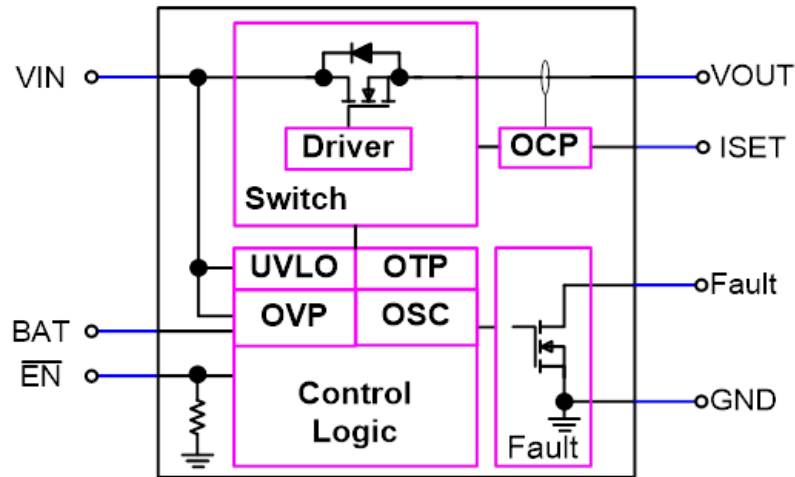

Figure 3. Function Block Diagram

Functional Pin Description

Pin NO.	DFN8	Description
VIN	1	Power source input. Connect a ceramic capacitor between VIN and GND.
GND	2	Ground.
NC	3	No connect.
Fault	4	Fault output pin. Open-drain output, device status.
$\overline{\text{EN}}$	5	Enable pin.
BAT	6	Battery voltage detector input. It can short this pin to gnd, if doesn't use this function.
ISET	7	OCP level setting by an external resistor to GND.
VOUT	8	Output through the power MOSFET.
	EP	Exposed pad. Connect EP to GND is suggested.

Absolute Maximum Ratings ^{Note1}

◇ VIN to GND	-----	-0.3V to +30V
◇ VOUT to GND	-----	-0.3V to +7V
◇ All Other Pin to GND	-----	-0.3V to +7V
◇ Operating Junction Temperature Range (T _J)	-----	-40°C to 150°C
◇ Operation Ambient Temperature Range	-----	-40°C to +105°C
◇ Storage Temperature Range	-----	-60°C to +125°C
◇ Maximum Soldering Temperature (at leads, 10sec)	-----	+260°C

Note1. Stresses beyond those listed under “Absolute Maximum Ratings” may cause permanent damage to the device. These are stress ratings only, and functional operation of the device at these or any other conditions beyond those indicated in the operational sections of the specifications is not implied. Exposure to absolute maximum rating conditions for extended periods may affect device reliability.

Thermal Information

◇ Thermal Resistance		
DFN-8, θ_{JA}	-----	76.11 °C/W

Recommended Operating Conditions

◇ Input Voltage, V _{IN}	-----	3.3V to 5V
◇ Output Current, I _{OUT}	-----	0.1A to 1.5A
◇ OCP Set Resistance, R _{SET}	-----	15k Ω to 250k Ω
◇ Junction Temperature, T _J	-----	-40°C to 125°C

Electrical Characteristics

($V_{IN} = 5V$, $T_A = 25^{\circ}C$, Unless Otherwise Specified)

Parameter	Symbol	Test Conditions	Min	Typ	Max	Units
General Function						
Power Source Voltage	V_{IN}	$T_J = +25^{\circ}C$	3.3	5	26	V
Input UVLO Threshold	V_{UVLO}	V_{IN} Rising	2.5	2.7	2.9	V
UVLO Threshold Hysteresis	ΔV_{UVLO}	Falling Hysteresis		200		mV
Power On Deglitch Time	$T_{Deglitch}$			8		ms
Soft Start Time	T_{SS}			8.2		ms
Power Source Current	I_{IN}	$V_{IN}=5V, \overline{EN}=L$		400		μA
Shutdown Current	I_{SD}	$V_{IN}=5V, \overline{EN}=H$		55		μA
Thermal Shutdown Threshold	T_{SD}			140		$^{\circ}C$
Thermal Shutdown Threshold Hysteresis	ΔT_{SD}			20		$^{\circ}C$
Logic Function						
\overline{EN} Threshold Voltage	V_{ENH}		1.4			V
	V_{ENL}				0.4	V
\overline{EN} Input Resistance to GND	I_{EN}	$\overline{EN}=2V$		15		μA
FAULT Output Logic Low		Sink 5mA		0.2		V
FAULT Logic High Leakage Current		Fault=5V			10	μA
Power MOS						
Switch On Resistance	$R_{DS(ON)}$	$I_{OUT}=1A$		160	250	m Ω
Protection Functions						
Input Over Voltage Protect threshold	V_{IOVP}	V_{IN} from 5V to 10V		6.8		V
Input OVP threshold Hysteresis	ΔV_{IOVP}	V_{IN} from 10V to 5V		50		mV
Input OVP Recovery Delay Time	T_{OVPR}			8.2		ms
Over Current Protection	I_{OCP}	$R_{SET} = 24.9K,$ $3.3V < V_{IN} < V_{IOVP}$		1		A
Short Circuit Current	I_{SCP}	$R_{SET} = 24.9K, V_{OUT}$ short to GND	0.65			A
OCP Blanking Time	T_{OCP}			200		μs
Over Current Recover Delay	T_{OCR}			65		ms
Battery Voltage OVP	V_{BOVP}	$V_{IN}=5V$		4.35		V
Battery OVP Hysteresis	ΔV_{BOVP}	$V_{IN}=5V$		0.275		V
Battery OVP Blanking Time	T_{BOVP}	$V_{IN}=5V$		200		μs
BAT Pin Leakage Current	I_{BAT}	$V_{IN}=5V, V_{BAT}=4.4V$			10	nA

Typical Performance Curves

$T_A=25^{\circ}\text{C}$, $V_{IN}=V_{OUT}=5\text{V}$, $V_{BAT}=4.2\text{V}$, $V_{DD}=5\text{V}$, $V_{EN}=0\text{V}$, unless otherwise specified.

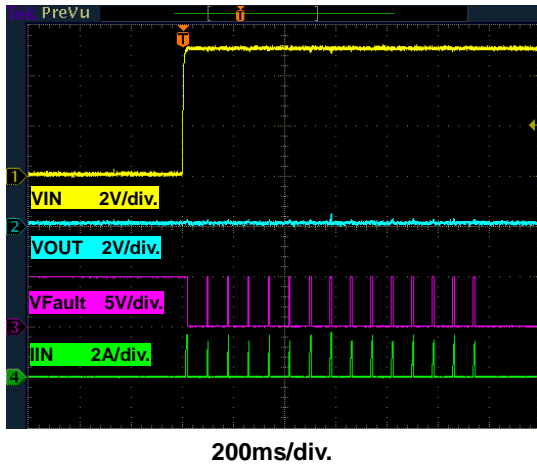

Figure 4. VOUT short to GND

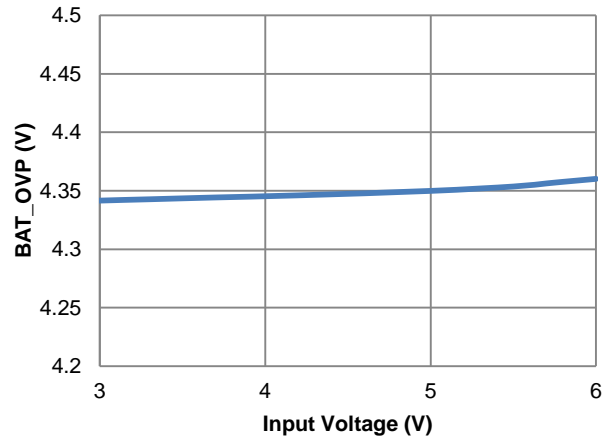

Figure 5. Input Voltage vs. Battery OVP

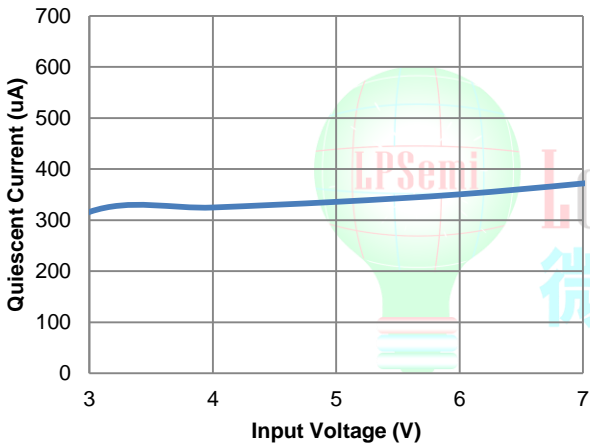

Figure 6. Input Voltage vs. Quiescent Current

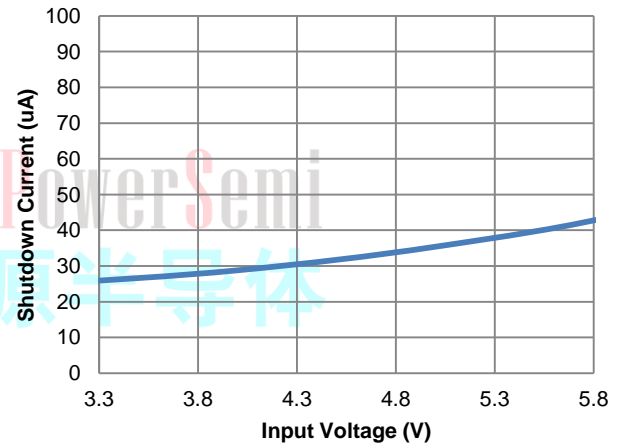

Figure 7. Input Voltage vs. Shutdown Current

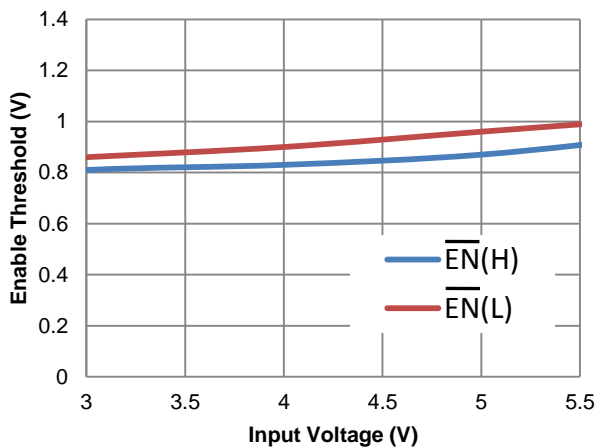

Figure 8. Input Voltage vs. Enable Threshold

Application Information

The LP5306 devices monitor the input voltage, battery voltage, and output current to protect the charging system of a Li-Ion battery. When enabled, the system is protected against input overvoltage by turning off an internal switch, immediately removing power from the charging circuit. For an over-current condition, the device limits the output current at the setting value, and if the over-current persists, the switch will turn off after a blanking time. Additionally, the device also monitors its own temperature and switches off if device too hot.

Under Voltage Lockout (UVLO)

The LP5306 had an UVLO internal circuit that enable the device once the voltage on the V_{IN} voltage exceeds the UVLO threshold voltage.

Input Over Voltage Protection

The LP5306 Input has an over voltage protection to protect the battery charging system. When the V_{IN} voltage rises above 6.8V(Typ.), the system will turns the switch off.

Battery Over Voltage Protection

The battery overvoltage threshold V_{BOVP} is internally set to 4.35V. If the battery voltage exceeds the threshold, the switch is turned off, and the Fault pin is go low. Once the battery voltage drops to $(V_{BOVP} - \Delta V_{BOVP})$, the switch is turned back on. And the switch is turned off permanently, when battery overvoltage occurs 15 times in one charge cycle. For cleared this event, the V_{IN} power or \overline{EN} need to re-cycled.

Over Temperature Protection

The LP5306 device enters over temperature protection(OTP) if its junction temperature exceeds 140°C (Typ.). During over temperature protection none of the device's functions are available. To resume normal operation the junction temperature need cool down, and the outputs will restart.

Enable Control

The LP5306 has an enable pin which can be used to enable or disable the device. When the \overline{EN} pin is driven high, the switch is turned off. The \overline{EN} pin has an internal pull-down resistor can be floating.

Fault Flag

The FAULT pin is open-drain output.

- Input Over Voltage
- Output Over Current
- Battery Over Voltage
- Over Temperature

Over Current Protection

The Over Current threshold can adjustable by a external resistor RSET connected from the ISET pin to GND. The equation is apply under below:

$$I_{OCP} = 25000 \div R_{SET}$$

If the output current exceeds the I_{OCP} threshold, the device limits the current for a blanking duration (T_{OCP}). If the output current is over the I_{SCP} for T_{OCP} , the switch will turn off. The Fault pin is set to low, too. The switches will re-soft start again after T_{OCR} . And the switch is turned off permanently; when over current event occurs 15 times in one charge cycle. For cleared this event, the V_{IN} power or \overline{EN} need to re-cycled.

Layout Consideration

The proper PCB layout and component placement are critical for all circuit. LP5306 is meant to protect downstream circuit. Here are some suggestions to the layout design.

1. Connected all ground together with one uninterrupted ground plane, which include power ground and analog ground.
2. The input and output capacitor should be located as closed as possible to the chip and ground plane.
3. Other components should be located close to the chip.

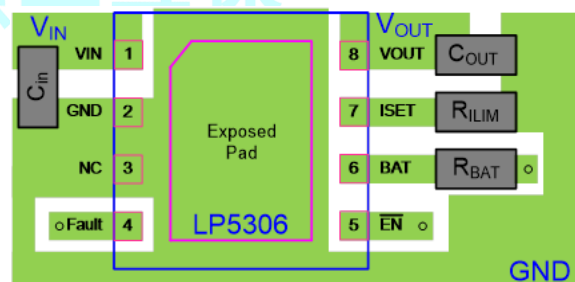
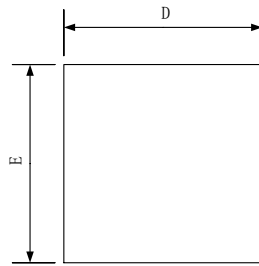

Figure 9. Recommended PCB Layout Diagram



Outline Information

DFN-8 Package (2x2) pitch 0.5 (Unit: mm)



TOP VIEW

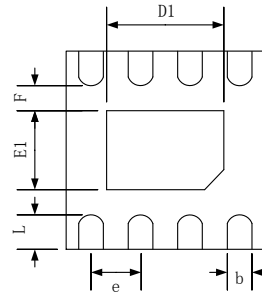

BOTTOM VIEW

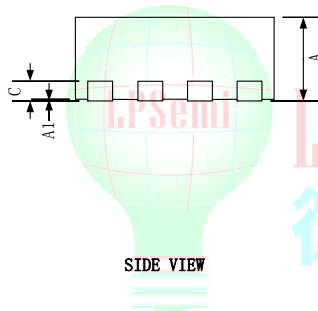

SIDE VIEW

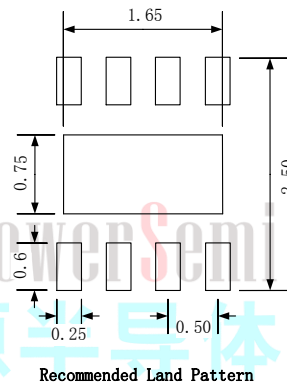

Recommended Land Pattern

SYMBOL	Dimensions In Millimeters		
	MIN	NOM	MAX
A	0.70	0.75	0.80
A1	0.00	0.02	0.05
b	0.18	0.25	0.30
c	0.20 REF		
D	1.90	2.00	2.10
D1	1.10	1.30	1.65
E	1.90	2.00	2.10
E1	0.60	0.75	0.85
e	0.50 BSC		
L	0.25	0.35	0.40
F	0.25	0.30	0.35