

One Cell Li-Ion Battery Protection IC

General Description

The LPB1003 product is a highly integrated solution for Li-Ion battery protection. It includes advanced power MOSFETs, precision voltage detection circuitry and delay circuitry for all the protection functions required in battery applications, including overcharge, overdischarge, overcurrent and load short circuit protection. Its accurate overcharge detection voltage ensures a safe and efficient charging cycle. The low standby current allows for almost no battery current to be consumed during storage.

The LPB1003 is available in an ultra-small SOT23-5 package. Its simple peripheral circuit requires only one external capacitor.

This chip is suitable for any electronic device that requires long-term continuous power supply from a Li-Ion battery.

Order Information

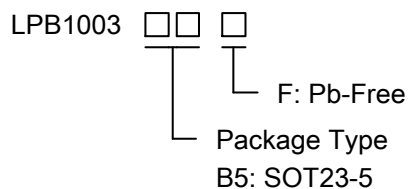

Applications

- ✧ Any application that requires long periods of power from a Li-Ion battery

Features

- ◆ Integrate Advanced Power MOSFET with Equivalent of 50mΩ $R_{SS(ON)}$
- ◆ Two-step Overcurrent Detection:
 - Overdischarge Current
 - Load Short Circuiting
- ◆ Overcharge Current Protection
- ◆ 0V Battery Charging Function
- ◆ Delay Times are generated inside
- ◆ High-accuracy Voltage Detection
- ◆ Low Current Consumption:
 - Operation Mode: 3.5μA typ.

Typical Application Circuit

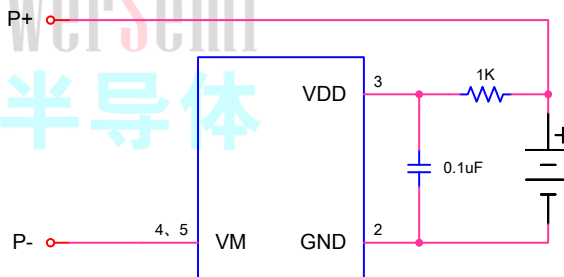

Marking Information

Device	Marking	Package	Shipping
LPB1003B5F	LPB 1003WX	SOT23-5	3K/REEL
Marking indication: W: Production week X: Series Number			

Functional Pin Description

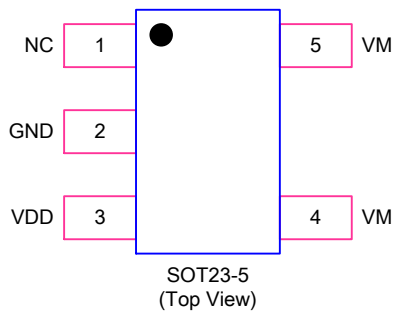
Package Type	Pin Configurations
SOT23-5	 <p>SOT23-5 (Top View)</p>

Pin Description

Pin	Name	Description
1	NC	No connector.
2	GND	Ground, connect the negative terminal of the battery to this pin
3	VDD	Power Supply
4, 5	VM	The negative terminal of the battery pack. The internal FET switch connects this terminal to GND

Function Diagram

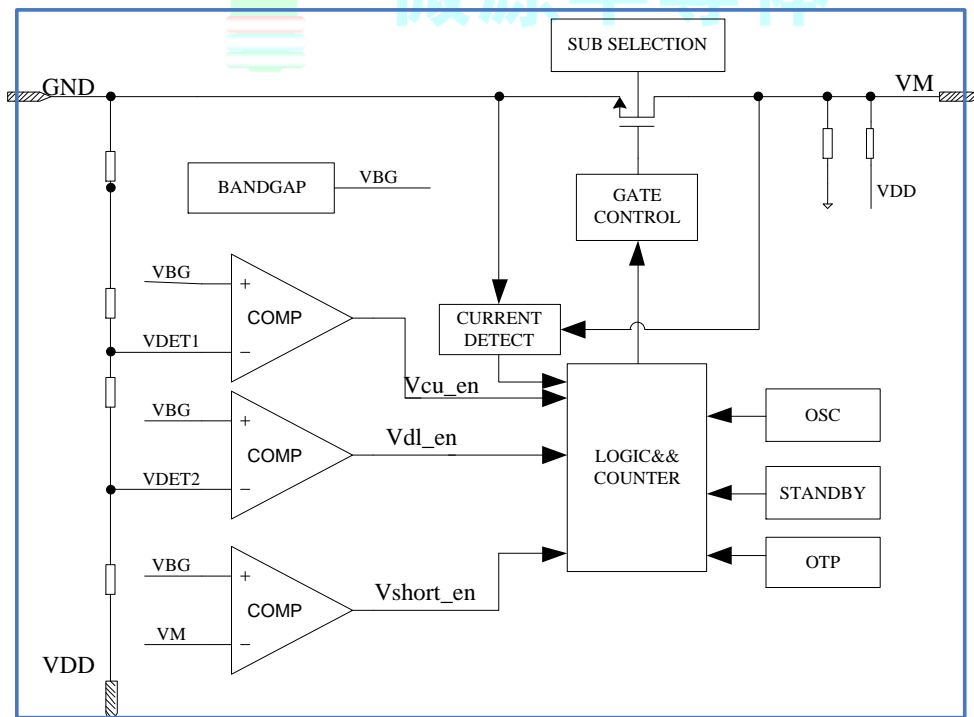

Absolute Maximum Ratings ^{Note 1}

- ◇ VDD to GND ----- -0.3V to 10V
- ◇ VM to GND ----- VDD-6V to VDD+0.3V

Note 1. Stresses beyond those listed under “Absolute Maximum Ratings” may cause permanent damage to the device. These are stress ratings only, and functional operation of the device at these or any other conditions beyond those indicated in the operational sections of the specifications is not implied. Exposure to absolute maximum rating conditions for extended periods may affect device reliability.

Recommended Operating Conditions

- ◇ Operating Ambient temperature ----- -40°C to +85°C
- ◇ Storage temperature ----- -55°C to +125°C

ESD Susceptibility

- ◇ HBM(Human Body Mode) ----- 2KV
- ◇ MM(Machine Mode) ----- 200V



Electrical Characteristics

(T_A=25°C, unless otherwise noted.)

Parameter	Symbol	Condition	Min	Typ	Max	Units
Current consumption						
Operating current	I _{DD}	V _{DD} =3.7V		3.5	6	uA
Stand-by current	I _{PD}	V _{DD} =2.4V		2.2		uA
Detection voltage						
Overcharge detection voltage	V _{OCP}		4.25	4.3	4.35	V
Overcharge release voltage	V _{OCR}		4.05	4.1	4.15	V
Overdischarge detection voltage	V _{ODP}		2.75	2.8	2.85	V
Overdischarge release voltage	V _{ODR}		2.88	3.0	3.12	V
Over discharge current detection voltage	V _{OI}		0.12	0.15	0.18	V
Overcharge current detection voltage	V _{CI}		-0.18	-0.15	-0.12	V
Short circuit current detection voltage	V _{SHORT}	V _{DD} =3.6V	0.5	0.8	1.1	V
Delay time						
Overcharge detection delay time	T _{OC}	V _{DD} =3.6V~4.4V	20	40	60	ms
Overdischarge detection delay time	T _{OD}	V _{DD} =3.6V~2.0V	15	30	50	ms
Overcurrent detection delay time	T _{OI}	V _{DD} =3.6V	2	6	11	ms
Short circuit current detection delay time	T _{SHORT}	V _{DD} =3.6V	100	250	400	us
Other						
MOS transistor on-resistance	R _{DS(ON)}	V _{DD} =3.7V, I _D =1.0A		50		mΩ
Continuous load current		V _{DD} =3.7V		3		A
Over temperature protection				155		°C
Over temperature protection recovery				120		°C
Charger voltage (0V charging)			1.2			V

Application Information

The LPB1003 monitors the voltage and current of a battery and protects it from being damaged due to overcharge voltage, overdischarge voltage, overdischarge current, and short circuit conditions by disconnecting the battery from the load or charger. These functions are required in order to operate the battery cell within specified limits. The device requires only one external capacitor. The MOSFET is integrated and its $R_{SS(ON)}$ is as low as $50m\Omega$ typical.

Normal operating mode

If no exception condition is detected, charging and discharging can be carried out freely. This condition is called the normal operating mode.

Overcharge Condition

When the battery voltage becomes higher than the overcharge detection voltage (V_{CU}) during charging under normal condition and the state continues for the overcharge detection delay time (t_{CU}) or longer, the LPB1003 stops the charging by controlling the FET. This condition is called the overcharge condition. The overcharge condition is released in the following two cases:

1. When the battery voltage drops below the overcharge release voltage (V_{CL}), the LPB1003 turns the charging control FET on and returns to the normal condition.
2. When a load is connected and discharging starts, the LPB1003 turns the charging control FET on and returns to the normal condition.

The release mechanism is as follows: the discharging current flows through an internal parasitic diode of the charging FET immediately after a load is connected and discharging starts, and the

VM pin voltage increases about 0.7V (forward voltage of the diode) from the GND pin voltage momentarily. The LPB1003 detects this voltage and releases the overcharge condition. Consequently, in the case that the battery voltage is equal to or lower than the overcharge detection voltage (V_{CU}), the LPB1003 returns to the normal condition immediately, but in the case the battery voltage is higher than the overcharge detection voltage (V_{CU}), the chip does not return to the normal condition until the battery voltage drops below the overcharge detection voltage (V_{CU}) even if the load is connected. In addition, if the VM pin voltage is equal to or lower than the overcurrent 1 detection voltage when a load is connected and discharging starts, the chip does not return to the normal condition.

Overdischarge Condition

When the battery voltage drops below the overdischarge detection voltage (V_{DL}) during discharging under normal condition and it continues for the overdischarge detection delay time (t_{DL}) or longer, the LPB1003 turns the discharging control FET off and stops discharging. This condition is called overdischarge condition.

After the discharging control FET is turned off, the VM pin is pulled up by the R_{VMD} resistor between VM and V_{DD} in LPB1003. Meanwhile when VM is bigger than 1.5V (typ.) (the load short-circuiting detection voltage), the current of the chip is reduced to the power-down current (I_{PDN}). This condition is called power-down condition. The VM and V_{DD} pins are shorted by the R_{VMD} resistor in the IC under the overdischarge and power-down conditions. The power-down condition is released when a charger is connected and the potential

difference between VM and V_{DD} becomes 1.3 V (typ.) or higher (load short-circuiting detection voltage). At this time, the FET is still off. When the battery voltage becomes the same as overdischarge detection voltage (V_{DL}) or higher, the LPB1003 turns the FET on and changes to the normal condition from the overdischarge condition.

Overcurrent Condition

When the discharging current becomes equal to or higher than a specified value (the VM pin voltage is equal to or higher than the overcurrent detection voltage) during discharging under normal condition and the state continues for the overcurrent detection delay time or longer, the LPB1003 turns off the discharging control FET to stop discharging. This condition is called overcurrent condition. (The overcurrent includes overcurrent, or load short-circuiting.)

The VM and GND pins are shorted internally by the R_{VMS} resistor under the overcurrent condition. When a load is connected, the VM pin voltage equals the V_{DD} voltage due to the load. The overcurrent condition returns to the normal condition when the load is released and the impedance between the P+ and P- pins becomes higher than the automatic recoverable impedance. When the load is removed, the VM pin goes back to the GND potential since the VM pin is shorted the GND pin with the R_{VMS} resistor. Detecting that the VM pin potential is lower than the overcurrent detection voltage (V_{IOV}), the IC returns to the normal condition.

Abnormal Charge Current Detection

If the VM pin voltage drops below the charger detection voltage (V_{CHA}) during charging under the normal condition and it continues for the overcharge detection delay time (t_{CU}) or longer, the LPB1003 turns the charging control FET off and stops charging. This action is called abnormal charge current detection. Abnormal charge current detection works when the discharging control FET is on and the VM pin voltage drops below the charger detection voltage (V_{CHA}). When an abnormal charge current flows into a battery in the overdischarge condition, the LPB1003 consequently turns the charging control FET off and stops charging after the battery voltage becomes the overdischarge detection voltage and the overcharge detection delay time (t_{CU}) elapses. Abnormal charge current detection is released when the voltage difference between VM pin and GND pin becomes lower than the charger detection voltage (V_{CHA}) by separating the charger. Since the 0V battery charging function has higher priority than the abnormal charge current detection function, abnormal charge current may not be detected by the product with the 0V battery charging function while the battery voltage is low.

Load Short-circuiting condition

If voltage of VM pin is equal or more than the short circuiting protection voltage (V_{SHORT}) and the duration exceeds the short-circuit delay time t_{short} , the LPB1003 will stop discharging and battery is disconnected from load. This status is released when voltage of VM pin is below short protection voltage (V_{SHORT}), such as when disconnecting the load.

Delay Circuits

The detection delay time for overdischarge current 2 and load short-circuiting starts when overdischarge current 1 is detected. As soon as overdischarge current 2 or load short-circuiting is detected over detection delay time for overdischarge current 2 or load short-circuiting, the LPB1003 stops discharging. When the battery voltage drops below the overdischarge detection voltage due to the overdischarge current, the LPB1003 will stop discharging by the overdischarge current detection. In this case, the battery voltage recovery rate is very slow. If the battery voltage after the overdischarge voltage detection delay time is still lower than the overdischarge detection voltage, the LPB1003 will shift to power-down.

0V Battery Charging Function ⁽¹⁾ ⁽²⁾ ⁽³⁾

This function enables the charging of a connected battery whose voltage is 0V by self-discharge. When a charger having 0V battery start charging charger voltage (V_{0CHA}) or higher is connected between B+ and B- pins, the charging control FET gate is fixed to VDD potential. When the voltage between the gate and the source of the charging control FET becomes equal to or higher than the turn-on voltage by the charger voltage, the charging control FET is turned on to start charging. At this time, the discharging control FET is off and the charging current flows through the internal parasitic diode in the discharging control FET. If the battery voltage becomes equal to or higher than the overdischarge release voltage (V_{DU}), the normal condition returns.

Note:

(1) Some battery providers do not recommend charging of completely discharged batteries. Please refer to battery providers before the selection of 0V battery charging function.

(2) The 0V battery charging function has higher priority than the abnormal charge current detection function. Consequently, a product with the 0V battery charging function charges a battery and abnormal charge current cannot be detected during the battery voltage is low (at most 1.8V or lower).

(3) When a battery is connected to the IC for the first time, the IC may not enter the normal condition in which discharging is possible. In this case, set the VM pin voltage equal to the GND voltage (short the VM and GND pins or connect a charger) to enter the normal condition.

Packaging Information

SOT23-5

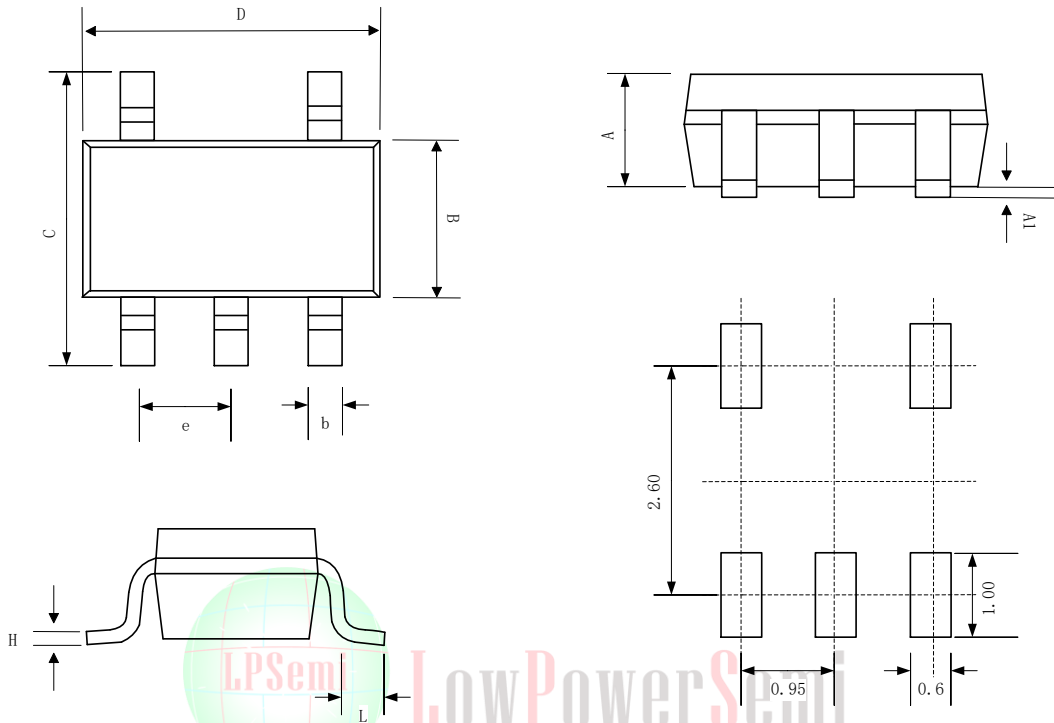

Recommended Land Pattern

SYMBOL	Dimensions In Millimeters		
	MIN	NOM	MAX
A	0.889	1.100	1.295
A1	0.000	0.050	0.152
B	1.397	1.600	1.803
b	0.28	0.35	0.559
C	2.591	2.800	3.000
D	2.692	2.920	3.120
e	0.95BSC		
H	0.080	0.152	0.254
L	0.300	0.450	0.610

Tape and Reel Information

REEL DIMENSIONS (Unit:mm)

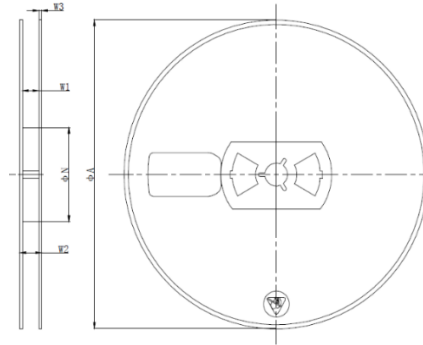

ΦA	W2
180±4	12±0.6

TAPE DIMENSIONS (Unit:mm)

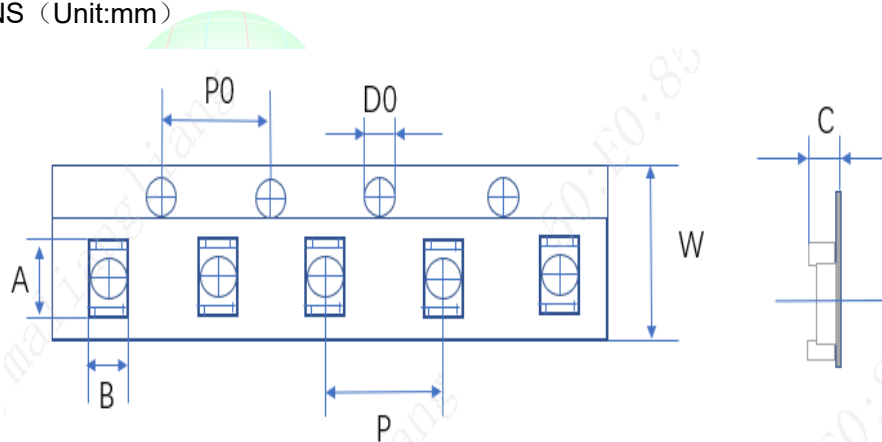

A	B	P0	P	D0	W	C
3.20±0.20	3.26±0.20	4.00±0.10	4.00±0.10	1.50±0.15	8.00±0.30	1.4±0.2

PIN1 AND TAPE FEEDING DIRECTION

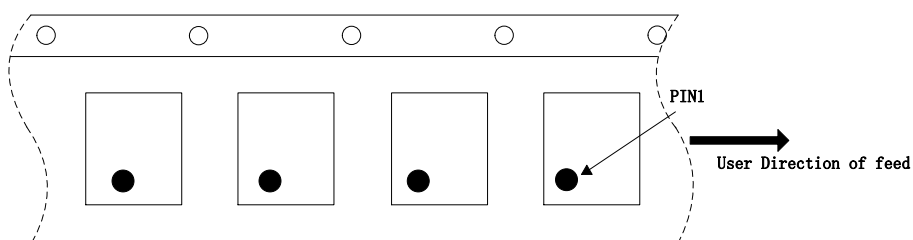

Classification of IR Reflow Profile

Profile Feature	Sn-Pb Eutectic Assembly	Pb-Free Assembly
Preheat/Soak		
Temperature Min(T_{SMIN})	100°C	150°C
Temperature Max(T_{SMAX})	150°C	200°C
Time(T_s) from (T_{SMIN} to T_{SMAX})	60~120 seconds	60~120 seconds
Ramp-up rate (T_L to T_P)	3°C/second max	3°C/second max
Liquidous temperature(T_L)	183°C	217°C
Time(t_L) maintained above T_L	60~150 seconds	60~150 seconds
Peak package body temperature (T_P)	For users T_P must not exceed the Classification temp in Table 1. For suppliers T_P must equal or exceed the Classification temp in Table 1.	For users T_P must not exceed the Classification temp in Table 2. For suppliers T_P must equal or exceed the Classification temp in Table 2.
Time(t_P)* within 5°C of the specified classification temperature(T_C), see Figure1	20* seconds	30* seconds
Ramp-down rate (T_P to T_L)	6°C/second max	6°C/second max
Time 25°C to peak temperature	6 minutes max	8 minutes max
* Tolerance for peak profile temperature (T_P) is defined as a supplier minimum and a user maximum.		

Table 1 Sn-Pb Eutectic Process - Classification Temperatures (TC)

Package Thickness	Volume mm3 <350	Volume mm3 ≥350
<2.5mm	235°C	220°C
≥2.5mm	220°C	220°C

Table 2 Pb-Free Process - Classification Temperatures (TC)

Package Thickness	Volume mm3 <350	Volume mm3 350~2000	Volume mm3 ≥350
<1.6mm	260°C	260°C	260°C
1.6mm~2.5mm	260°C	250°C	245°C
>2.5mm	250°C	245°C	245°C

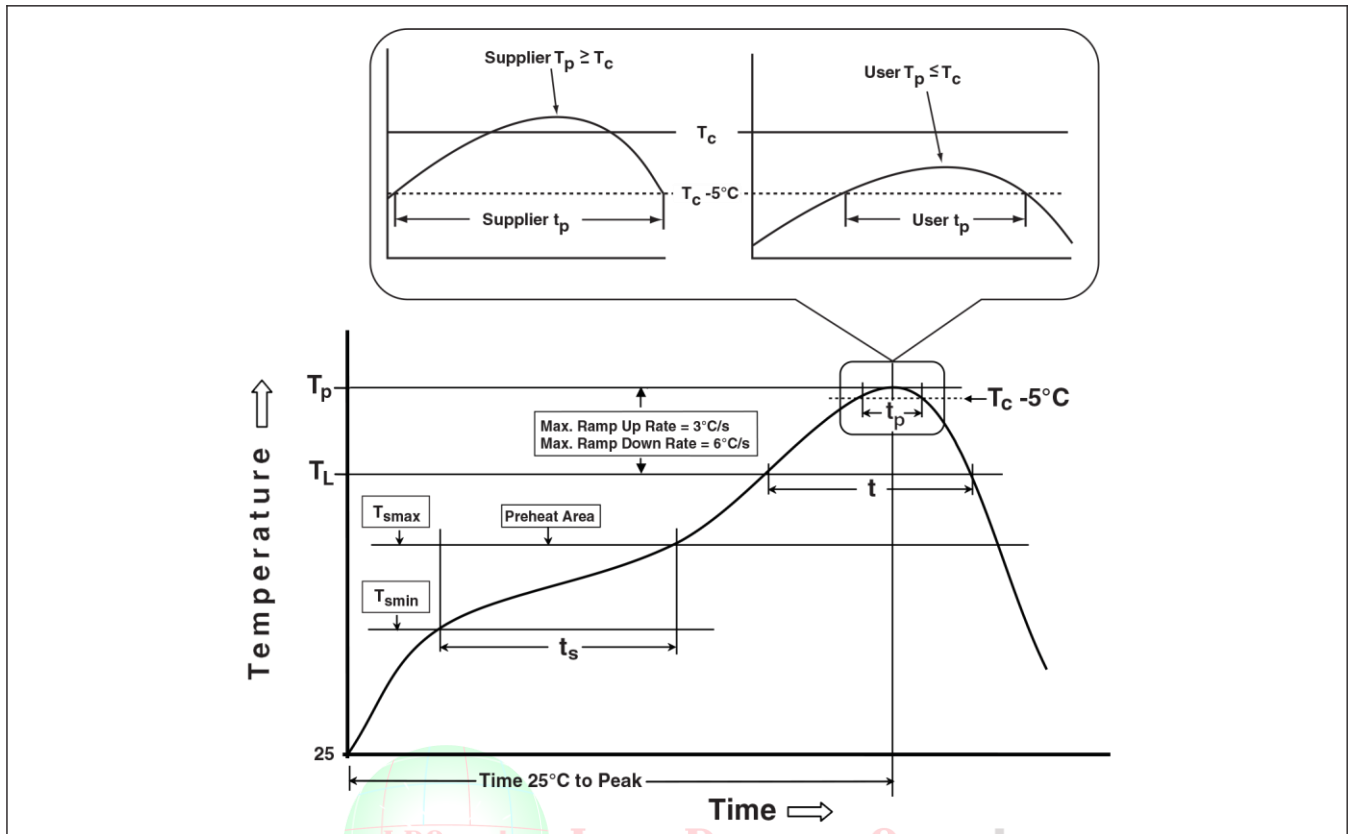

Figure1 Classification Profile (Not to scale)

Products Shipped Conform to “ROHS” Standards;

Moisture Sensitivity Level : MSL3 (CONDITION : $\leq 30\text{ }^{\circ}\text{C}/60\%\text{RH}$, Time control:168 hours) ;