



Features

- Up to 94% efficiency
- Output completely off at Shutdown Mode
- Output voltage Up to 20V
- Over Current Protection
- 450KHz fixed frequency switching
- High switch on current: 10A
- Available in ESOP-8/DFN-10(3*3mm) Package

Applications

- Battery products
- Host Products
- Panel

Ordering Information

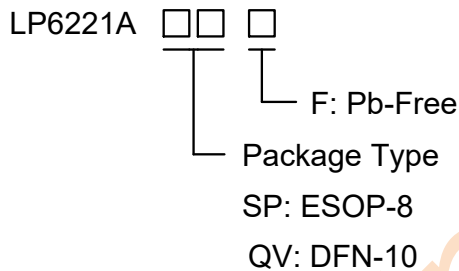

Description

The LP6221A is a current mode boost DC-DC converter. Its PWM circuitry with built-in 10A current power MOSFET makes this converter highly power efficiently. The LP6221A implements a constant frequency 450KHz PWM control scheme. The LP6221A can drive up to 20V output voltage

The LP6221A includes under-voltage lockout, current limiting, and thermal overload protection to prevent damage in the event of an output overload. The LP6221A is available in ESOP-8 / DFN-10 package.

Typical Application Circuit

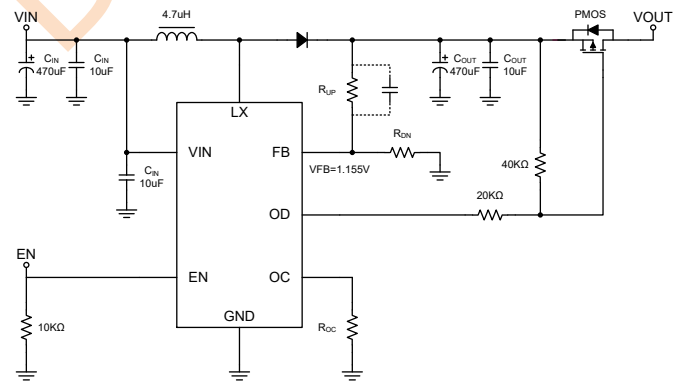

Marking Information

Device	Marking	Package	Shipping
LP6221ASPF	LPS LP6221 YWXXX	ESOP-8	4K/REEL
LP6221AQVF	LPS LP6221A YWX	DFN-10	5K/REEL

Marking indication:

Y is year code. W is week code. X is series number.



Pin Configuration

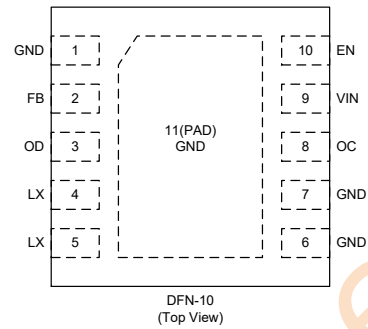
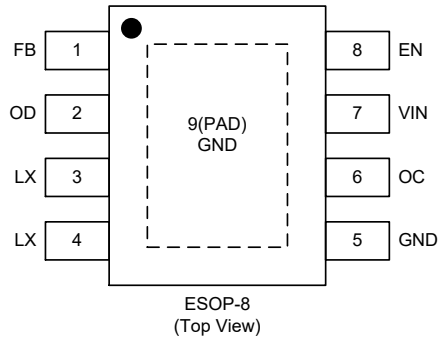

Pin Description

Pin Name	Pin NO.		Description
	ESOP8	DFN-10	
FB	1	2	Regulation Feedback Input. The feedback voltage is 1.155V
OD	2	3	Output Disconnect Control Pin.
LX	3/4	4/5	Switching Pin.
GND	5/9	1/6/7/11	Ground Pin.
OC	6	8	Over Current Protection Program Pin. Connect a resistance to GND.
VIN	7	9	Power Supply Pin.
EN	8	10	Chip Enable Pin. Active high



Absolute Maximum Ratings (Note 1)

- VIN to GND ----- -0.3V to 16V
- LX to GND ----- -0.3V to 22V
- OC/FB to GND ----- -0.3V to 6V
- Other to GND ----- -0.3V to 15V
- Maximum Junction Temperature (T_J) ----- 150°C
- Operating Ambient Temperature Range (T_A) ----- -40°C to 85°C
- Maximum Soldering Temperature (At leads, 10 sec) ----- 260°C

*Note 1: Stresses beyond those listed under “Absolute Maximum Ratings” may cause permanent damage to the device. These are stress ratings only, and functional operation of the device at these or any other conditions beyond those indicated in the operational sections of the specifications is not implied. Exposure to absolute maximum rating conditions for extended periods may affect device reliability.

Thermal Information

- Maximum Power Dissipation (P_D , ESOP8 , $T_A \leq 25^\circ\text{C}$) ----- 2W
- Thermal Resistance (θ_{JA} , ESOP8) (Note 2) ----- 46°C/W
- Maximum Power Dissipation (P_D , DFN-10 , $T_A \leq 25^\circ\text{C}$) ----- 1.5W
- Thermal Resistance (θ_{JA} ,DFN-10) (Note 2) ----- 65°C/W

*Note 2: Measured using 2S2P JEDEC standard PCB with ambient temperature < 25°C

ESD Susceptibility

- HBM(Human Body Mode) ----- 2KV
- MM(Machine Mode) ----- 200V



Electrical Characteristics

The specifications which apply over the full operating temperature range, otherwise specifications are at TA=25°C, VIN = 5V, unless otherwise noted.

Parameter	Symbol	Test Conditions	Min	Typ.	Max	Units
Input Supply Voltage	V _{IN}		2.6		15	V
Output Voltage Range	V _{OUT}				20	V
Input Supply Current	I _{CC}	V _{FB} =1.5V		0.15		mA
Shutdown Current	I _{SD}	V _{EN} =0		1		μA
Input UVLO Threshold	V _{UVLO}	V _{IN} Rising		2.3		V
UVLO Threshold Hysteresis	V _{UVLO(HYS)}	Falling Hysteresis		150		mV
Feedback Voltage	V _{FB}		1.132	1.155	1.179	V
FB Leakage Current	I _{FB}	V _{FB} =1.5V			100	nA
Internal Oscillator Frequency	F _{OSC}		350	450	550	kHz
Maximum Duty Cycle	D _{MAX}			90		%
Switch On Resistance	R _{DS(ON)}			15		mΩ
OC Voltage	V _{OC}			0.6		V
Current Limit Protection	I _{Limit}	V _{OUT} =12V R _{OC} =NC		6		A
		V _{OUT} =12V R _{OC} =10KΩ		10		A
		V _{OUT} =12V R _{OC} =12KΩ		8		A
		V _{OUT} =12V R _{OC} =20KΩ		4		A
		V _{OUT} =12V R _{OC} =30KΩ		2		A
EN Threshold Voltage	V _{IH}	Logic High.	1.4			V
	V _{IL}	Logic Low			0.4	V
Thermal Shutdown Threshold	T _{SD}	Temperature Rising		150		°C
Thermal Shutdown Hysteresis	ΔT _{SD}			20		°C



Typical Characteristics

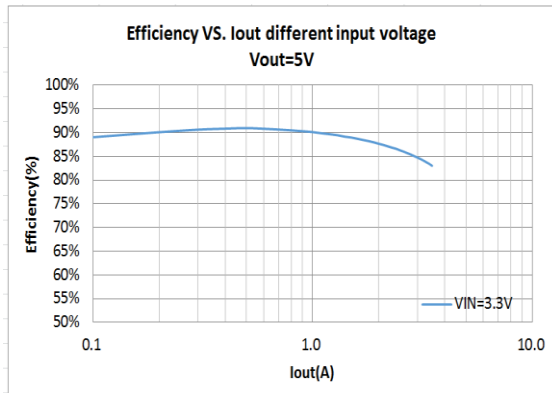

Figure 1. $V_{OUT}=5V$, Efficiency, $L=4.7\mu H$

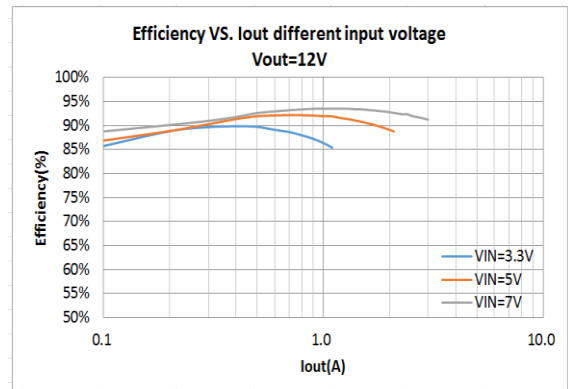

Figure 2. $V_{OUT}=12V$, Efficiency, $L=4.7\mu H$

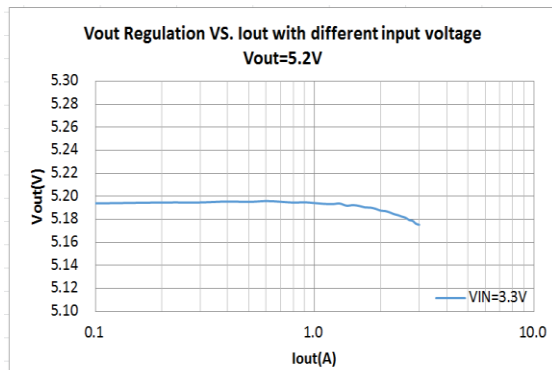

Figure 3. $V_{OUT}=5.0V$, Voltage Regulation

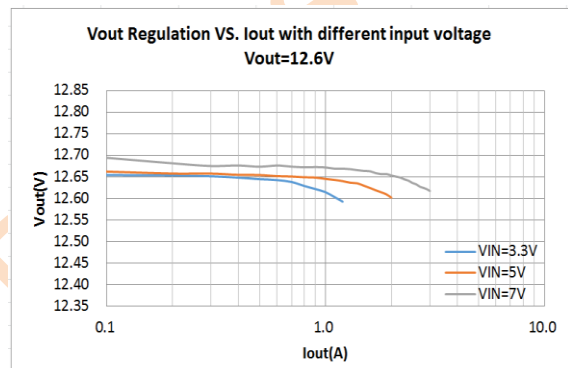

Figure 4. $V_{OUT}=12V$, Voltage Regulation

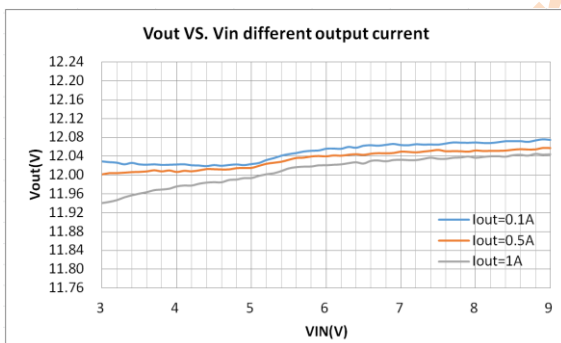

Figure 5. $V_{OUT}=12V$, Voltage Regulation

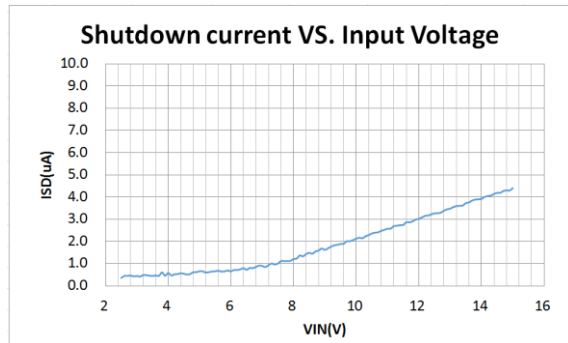

Figure 6. Shutdown Current, $V_{EN}=0$



Typical Characteristics

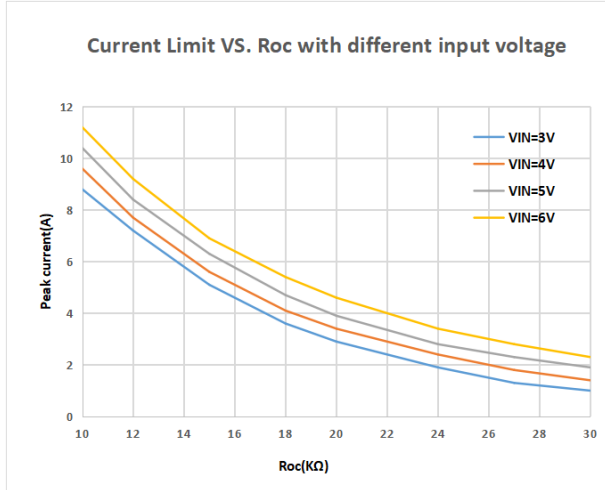

Figure 7. $V_{OUT}=12V$, $L=4.7\mu H$

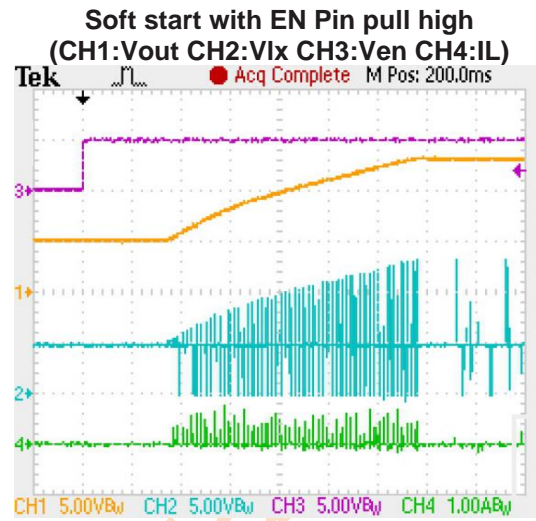

Figure 8. $V_{OUT}=12V$, $L=4.7\mu H$



Application Information

The LP6221A uses a fixed frequency, peak current mode boost regulator architecture to regulate voltage at the feedback pin. At the start of each oscillator cycle the MOSFET is turned on through the control circuitry. To prevent sub-harmonic oscillations at duty cycles greater than 50 percent, a stabilizing ramp is added to the output of the current sense amplifier and the result is fed into the negative input of the PWM comparator. When this voltage equals the output voltage of the error amplifier the power MOSFET is turned off. The voltage at the output of the error amplifier is an amplified version of the difference between the 1.155V bandgap reference voltage and the feedback voltage. In this way the peak current level keeps the output in regulation. If the feedback voltage starts to drop, the output of the error amplifier increases. These results in more current to flow through the power MOSFET, thus increasing the power delivered to the output. The LP6221A has internal soft start to limit the amount of input current at startup and to also limit the amount of overshoot on the output.

Setting the Output Voltage

Set the output voltage by selecting the resistive voltage divider ratio. The voltage divider drops the output voltage to the 1.155V feedback voltage. Use a 20K resistor for R_{DN} of the voltage divider. Determine the high-side resistor R_{UP} by the equation:

$$V_{OUT} = \left(\frac{R_{UP}}{R_{DN}} + 1 \right) \times V_{FB}$$

Resistor Selections for Different Output Voltage Settings (Standard 1% Resistors Substituted For Calculated Values).

Current Limitation

The internal power-MOS switch current is monitored cycle-by-cycle and is limited to the value not exceed 10A(Typ.). When the switch current reaches the limited value, the internal power-MOS is turned off immediately until the next cycle. Keep traces at this pin as short as possible. Do not put capacitance at this pin.

Current limit program

A resistor between OC and GND pin programs peak switch current. When the ROC value is between 10K and 30K, the current limit will be set from 10A to 2A. If the OC pin is left floating, the default current limit is 6A. Keep traces at this pin as short as possible. Do not put capacitance at this pin.

Diode Selection

To achieve high efficiency, Schottky diode is good choice for low forward drop voltage and fast switching time. The output diode rating should be able to handle the maximum output voltage, average power dissipation and the pulsating diode peak current.

Output Disconnect Control Function

The LP6221A can control the external MOS switch through the OD pin. When EN is low, the OD pin is in a high-impedance state. When EN is high, the OD pin is pulled down to GND. This allows the asynchronous boost to cut off the output in shutdown mode.



Package Dimensions

ESOP-8

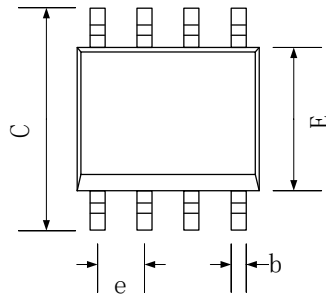

TOP VIEW

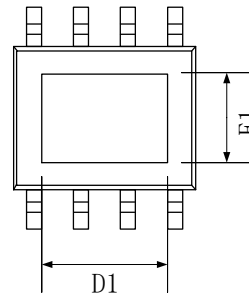

BOTTOM VIEW

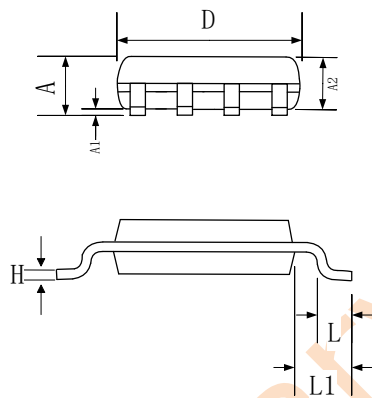

SIDE VIEW

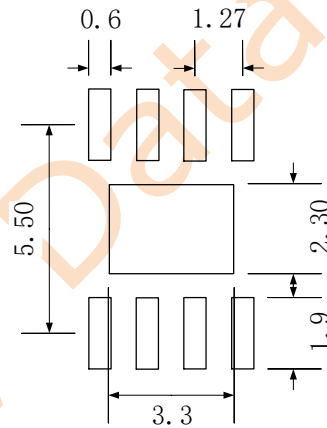

Recommended Land Pattern

SYMBOL	Dimensions In Millimeters			Dimensions In Inches		
	MIN	NOM	MAX	MIN	NOM	MAX
A	1.35	-	1.75	0.053	-	0.069
A1	0.00	-	0.15	-	-	0.006
A2	1.35	-	1.6	0.053	-	0.063
b	0.30	0.40	0.50	0.012	0.016	0.019
C	5.70	6.00	6.30	0.224	0.236	0.248
D	4.70	4.90	5.10	0.185	0.193	0.201
D1	3.20 REF			0.126 REF		
E	3.70	3.90	4.10	0.146	0.154	0.161
E1	2.30 REF			0.091 REF		
e	1.27 BSC			0.050 BSC		
L	0.40	0.60	0.80	0.016	0.024	0.031
L1	1.05 REF			0.041 REF		
H	0.20 REF			0.008 REF		



DFN-10

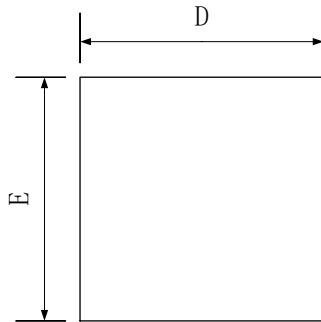

TOP VIEW

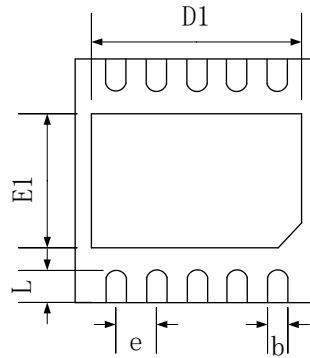

BOTTOM VIEW

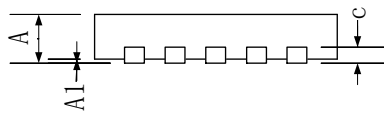

SIDE VIEW

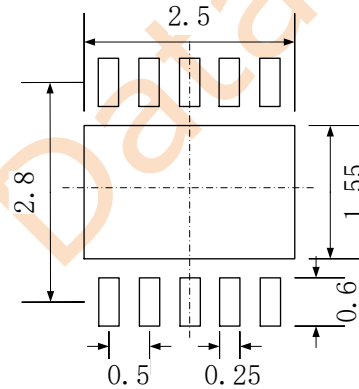

Recommended Land Pattern

SYMBOL	Dimensions In Millimeters			Dimensions In Inches		
	MIN	NOM	MAX	MIN	NOM	MAX
A	0.70	0.75	0.80	0.028	0.030	0.032
A1	0.00	0.02	0.05	0.000	0.001	0.002
b	0.18	0.25	0.30	0.007	0.010	0.012
C	0.20 REF			0.008 REF		
D	2.90	3.00	3.10	0.114	0.118	0.122
D1	2.40	2.50	2.60	0.094	0.098	0.102
E	2.90	3.00	3.10	0.114	0.118	0.122
E1	1.45	1.55	1.65	0.057	0.061	0.065
e	0.50 BSC			0.020 BSC		
L	0.30	0.40	0.50	0.012	0.016	0.020