

340KHz, 2A Step-down Converter With Soft-Start

General Description

The LP6482 contains an independent 340KHz constant frequency, current mode, PWM step-down converters. The converter integrates a main switch and synchronous rectifier for high efficiency without an external schottky diode. The converter can supply 2A of load current. The LP6482 can also run at 98% duty cycle for low dropout applications. It provides fast transient response and cycle-by-cycle limit with current mode control.

The LP6482 is available in a SOP8 package and is rated over the -40°C to 85°C temperature range.

Order Information

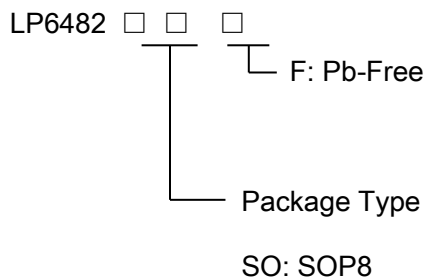

Features

- ◆ Input Voltage Range: 4.5V to 30V
- ◆ Output Voltage Range: 0.6V to 12V
- ◆ 2A Load Current
- ◆ Up to 95% Efficiency
- ◆ 340KHz Switching Frequency
- ◆ Short Circuit Protection
- ◆ Thermal Fault Protection
- ◆ SOP8 Package
- ◆ RoHS Compliant and 100% Lead (Pb)-Free

Applications

- ◇ Portable Media Players
- ◇ Cellular and Smart mobile phone
- ◇ PDA/DSC
- ◇ GPS Applications

Marking Information

Device	Marking	Package	Shipping
LP6482SOF	LPS LP6482 YWXXX	SO:SOP8	4K/REEL
Y: Year code. W: Week code. X: Batch numbers.			

Functional Pin Description

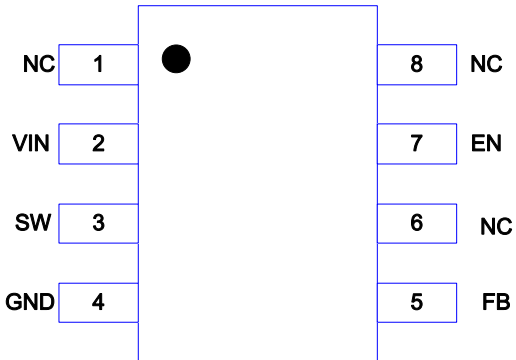
Package Type	Pin Configurations
SOP-8	

Pin Description

Pin	Name	Description
1/6/8	NC	No Connector.
2	VIN	Supply Input.
3	SW	Switch Mode Connection to Inductor. This pin connects to the drains of the internal main and synchronous power MOSFET switches.
4	GND	Ground.
5	FB	Feedback Input. Connect FB to the center point of the external resistor divider. Normal voltage for this pin is 0.6V.
7	EN	Enable Control Input. Drive EN above 2.5V to turn on the Channel. Drive EN below 0.4V to turn it off (shutdown current < 0.1μA).

Typical Application Circuit

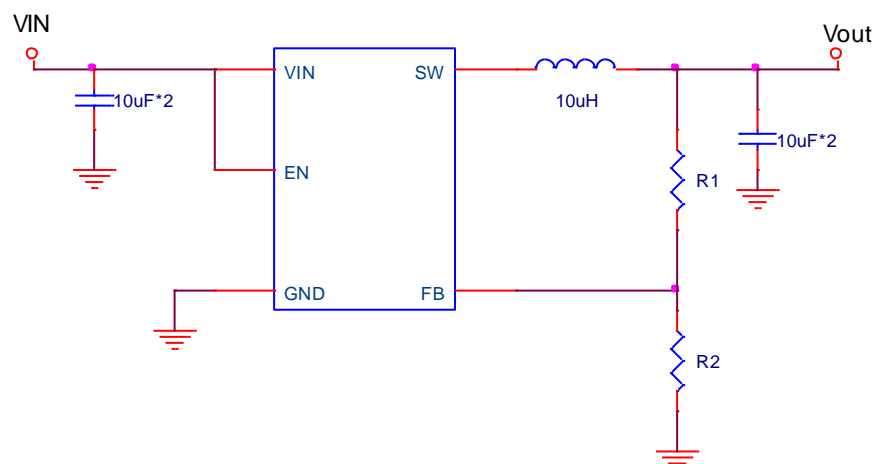

Function Diagram

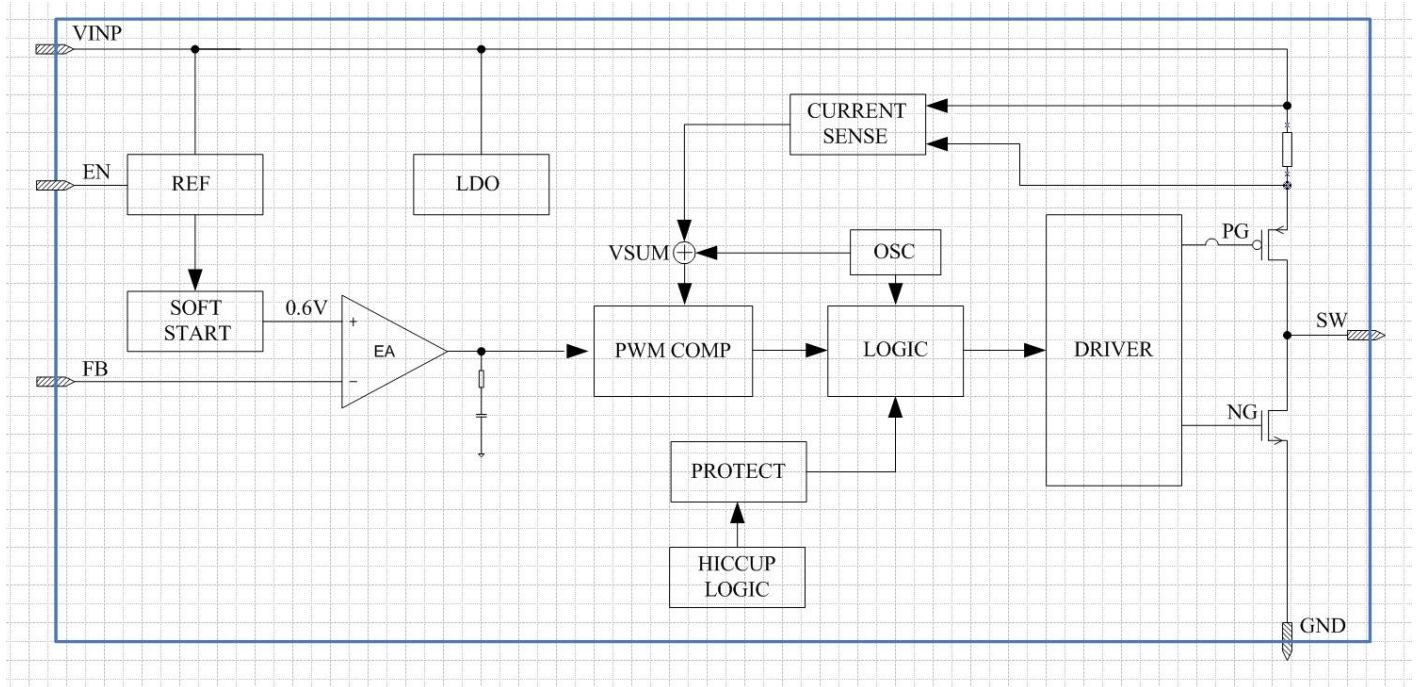

Absolute Maximum Ratings ^{Note 1}

- ✧ VIN/SW/EN to GND ----- 36V
- ✧ FB to GND (VFB) ----- -0.3V to 6V
- ✧ Junction Temperature ----- 150°C
- ✧ Storage Temperature ----- -65°C to 125°C
- ✧ Operating Ambient Temperature Range (T_A) ----- -40°C to 85°C
- ✧ Maximum Soldering Temperature (at leads, 10sec) ----- 260°C

Note 1. Stresses beyond those listed under "Absolute Maximum Ratings" may cause permanent damage to the device. These are stress ratings only, and functional operation of the device at these or any other conditions beyond those indicated in the operational sections of the specifications is not implied. Exposure to absolute maximum rating conditions for extended periods may affect device reliability.

Thermal Information

- ✧ Maximum Power Dissipation (SOP8, P_D, T_A=25°C) ----- 1.5W
- ✧ Thermal Resistance (SOP8, θ_{JA}) ----- 80°C/W

ESD Susceptibility

- ✧ HBM(Human Body Mode) ----- 2KV
- ✧ MM(Machine Mode) ----- 200V

Electrical Characteristics

$V_{IN}=12V, V_{EN}=5V, L=10\mu H, T_A=25^{\circ}C$, unless otherwise noted

Symbol	Parameter	Condition	Min	Typ	Max	Units
V _{IN}	Input Voltage		4.5		30	V
V _{IN-OVP}	V _{IN} OVP Voltage Lockout Threshold			32		
V _{OUT}	Output Voltage Range		0.6		12	V
I _Q	Quiescent Current	V _{IN} =12V		10		mA
I _{SHDN}	Shutdown Current	EN=GND		10		μA
I _{LIM}	P-Channel Current Limit		3			A
R _{DS(ON)_H}	High-Side Switch On Resistance			80		mΩ
R _{DS(ON)_L}	Low-Side Switch On Resistance			60		mΩ
I _{LX_LEAK}	LX Leakage Current	V _{EN} =0V, V _{SW} =0 or 5V, V _{IN} =5V		1		μA
V _{FB}	Feedback Threshold Voltage Accuracy	V _{IN} =12V	0.588	0.6	0.612	V
I _{FB}	FB Leakage Current	V _{OUT} =5.0V			30	nA
f _{OSC}	Oscillator Frequency			340		KHz
t _s	Startup Time	From Enable to Output Regulation		130		mS
T _{SD}	Over-Temperature Shutdown Threshold			150		°C
T _{HYS}	Over-Temperature Shutdown Hysteresis			20		°C
V _{EN(L)}	Enable Threshold Low				0.4	V
V _{EN(H)}	Enable Threshold High		2.5			V
I _{EN}	Enable Current	V _{IN} =12V, V _{EN} =12V		5		μA

Note: Output Voltage: $V_{OUT} = V_{FB} \times (1 + R_1 / R_2)$ Volts;



Typical Operating Characteristics

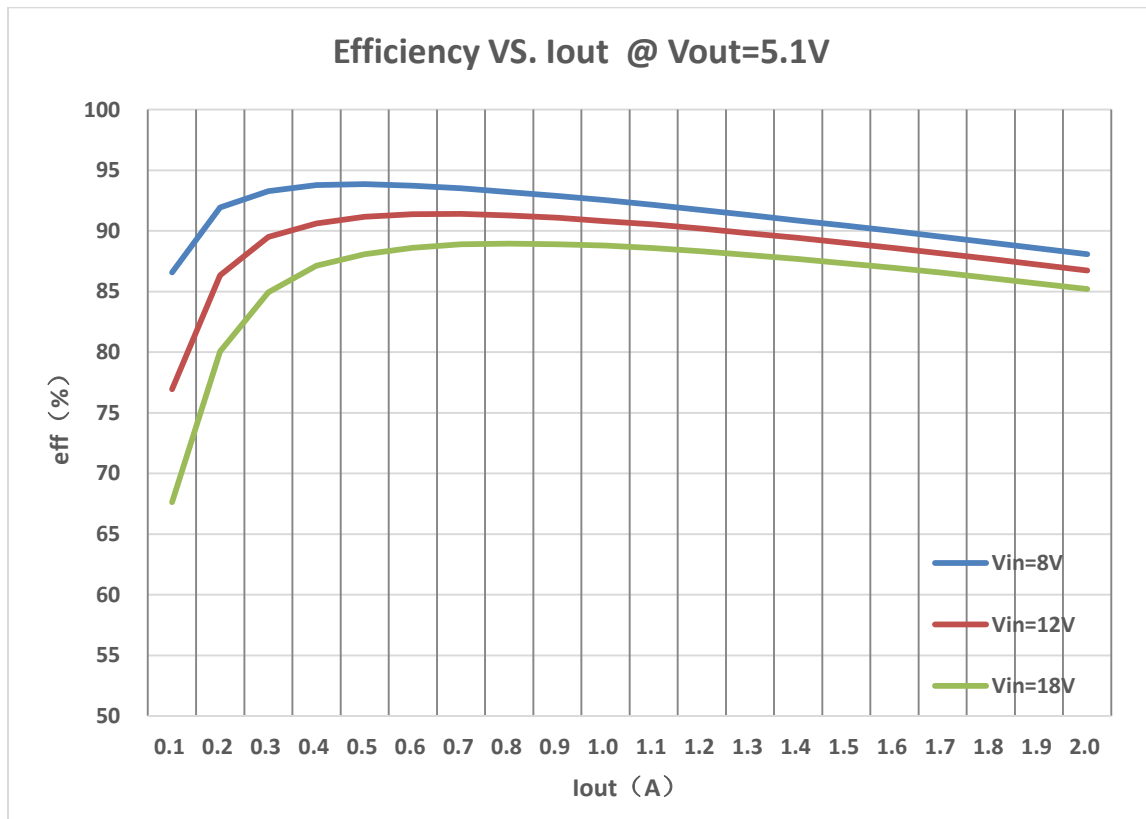

微源半导体

Application Information

The LP6482 operates by a constant frequency, current mode architecture. The output voltage is set by an external divider returned to the FB pin. An error amplifier compares the divided output voltage with a reference voltage of 0.6V and adjusts the peak inductor current accordingly.

Thermal Protection

The total power dissipation in LP6482 is limited by a thermal protection circuit. When the device temperature rises to approximately 150°C, this circuit turns off the output, allowing the IC to cool. The thermal protection circuit can protect the device from being damaged by overheating in the event of fault conditions. Continuously running the LP6482 into thermal shutdown degrades device reliability.

Setting Output Voltage

The output voltage is set with a resistor divider from the output node to the FB pin. It is recommended to use divider resistors with 1% tolerance or better. To improve efficiency at very light loads consider using larger value resistors. If the values are too high the regulator is more susceptible to noise and voltage errors from the FB input current are noticeable. For most applications, a resistor in the 10kΩ to 1MΩ range is suggested for R_{UP} and R_{DN}. The output voltage is established by the following equations

$$V_{OUT} = 0.6V \times (1 + R_1/R_2)$$

Where V_{REF} is 0.6V.

Inductor Selection

The inductor is required to supply constant current to the output load while being driven by the switched

input voltage. A larger value inductor results in less ripple current and lower output ripple voltage. However, the larger value inductor has a larger physical size, higher series resistance, and lower saturation current. Choose an inductor that does not saturate under the worst-case load conditions. A good rule for determining the inductance is to allow the peak-to-peak ripple current in the inductor to be approximately 30% of the maximum load current. The inductance value can be calculated by the equation:

$$L = (V_{OUT}) \times (V_{IN} - V_{OUT}) / (V_{IN} \times f \times \Delta I)$$

Output Capacitor

The output capacitor is required to maintain the DC output voltage. Low ESR capacitors are preferred to keep the output voltage ripple low. The characteristics of the output capacitor also affect the stability of the regulator control loop. Ceramic, tantalum, or low ESR electrolytic capacitors are recommended. In the case of ceramic capacitors, the impedance at the switching frequency is dominated by the capacitance. The output voltage ripple is estimated to be:

$$V_{RIPPLE} = 1.4 \times V_{IN} \times (f_{LC}/f)^2$$

Where V_{RIPPLE} is the output ripple voltage, V_{IN} is the input voltage, f_{LC} is the resonant frequency of the LC filter, f is the switching frequency. In the case of tantalum or low ESR electrolytic capacitors, the ESR dominates the impedance at the switching frequency, and so the output ripple is calculated as:

$$V_{RIPPLE} \approx \Delta I \times R_{ESR}$$

Where V_{RIPPLE} is the output voltage ripple, ΔI is the inductor ripple current, and R_{ESR} is the equivalent series resistance of the output capacitors.



Packaging Information

SOP8

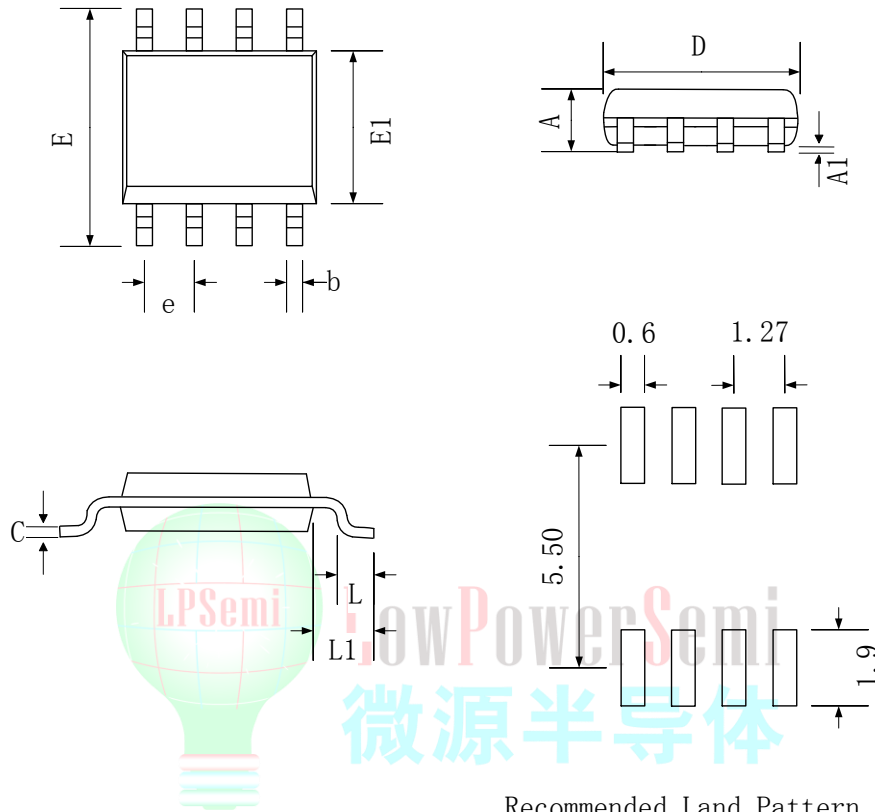

Recommended Land Pattern

SYMBOL	Dimensions In Millimeters		
	MIN	NOM	MAX
A	1.35	-	1.75
A1	0.10	-	0.25
b	0.30	0.40	0.50
c	0.20 REF		
D	4.70	4.90	5.10
E	5.70	6.00	6.30
E1	3.70	3.90	4.10
e	1.27 BSC		
L	0.40	0.60	0.80
L1	1.05 REF		

Classification of IR Reflow Profile

Profile Feature	Sn-Pb Eutectic Assembly	Pb-Free Assembly
Preheat/Soak		
Temperature Min(T_{SMIN})	100°C	150°C
Temperature Max(T_{SMAX})	150°C	200°C
Time(T_s) from (T_{SMIN} to T_{SMAX})	60~120 seconds	60~120 seconds
Ramp-up rate (T_L to T_P)	3°C/second max	3°C/second max
Liquidous temperature(T_L)	183°C	217°C
Time(t_L) maintained above T_L	60~150 seconds	60~150 seconds
Peak package body temperature (T_P)	For users T_P must not exceed the Classification temp in Table 1. For suppliers T_P must equal or exceed the Classification temp in Table 1.	For users T_P must not exceed the Classification temp in Table 2. For suppliers T_P must equal or exceed the Classification temp in Table 2.
Time(t_P)* within 5°C of the specified classification temperature(T_C), see Figure 1	20* seconds	30* seconds
Ramp-down rate (T_P to T_L)	6°C/second max	6°C/second max
Time 25°C to peak temperature	6 minutes max	8 minutes max
* Tolerance for peak profile temperature (T_P) is defined as a supplier minimum and a user maximum.		

Table 1 Sn-Pb Eutectic Process - Classification Temperatures (T_C)

Package Thickness	Volume mm^3 <350	Volume mm^3 ≥350
<2.5mm	235°C	220°C
≥2.5mm	220°C	220°C

Table 2 Pb-Free Process - Classification Temperatures (T_C)

Package Thickness	Volume mm^3 <350	Volume mm^3 350~2000	Volume mm^3 ≥350
<1.6mm	260°C	260°C	260°C
1.6mm~2.5mm	260°C	250°C	245°C
>2.5mm	250°C	245°C	245°C

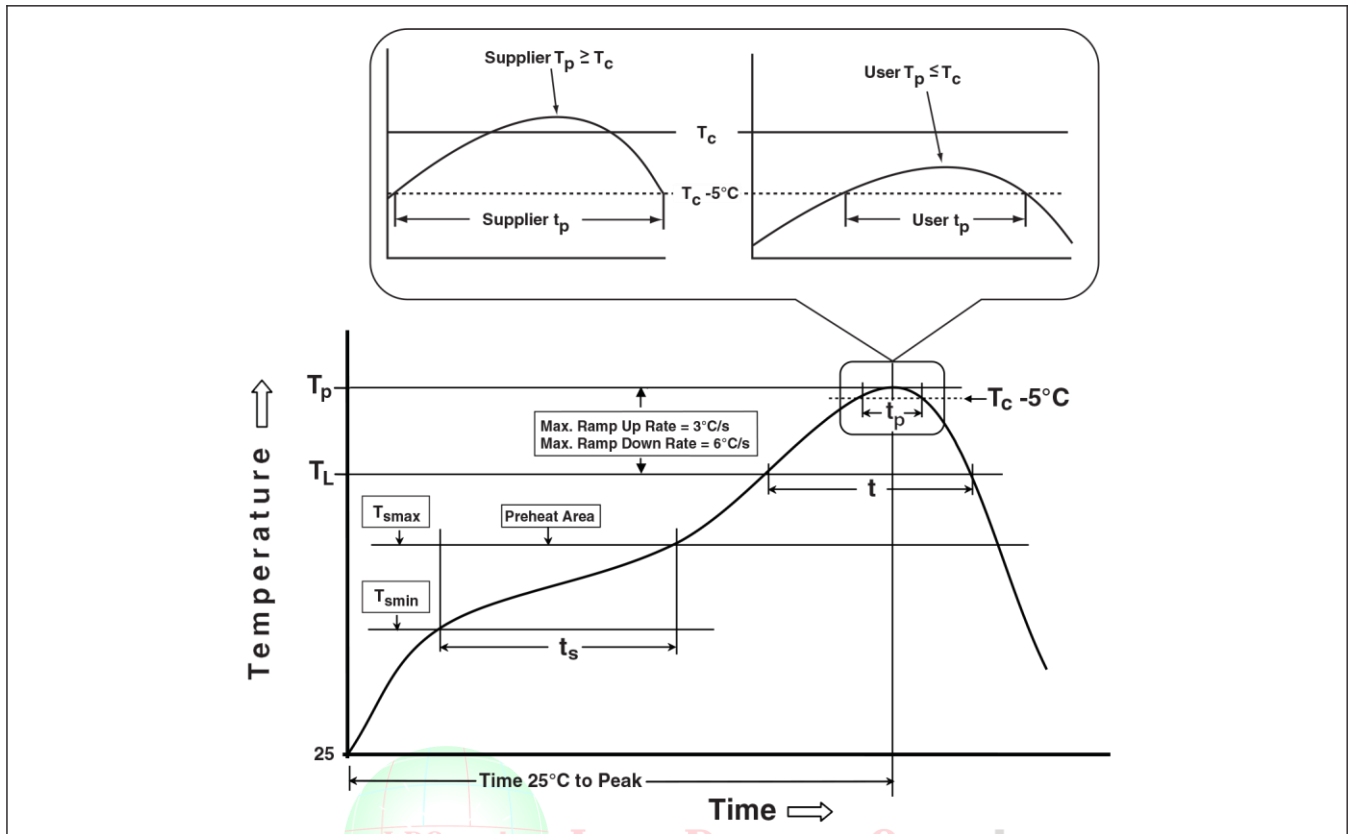

Figure 1 Classification Profile (Not to scale)

Products shipped conform to “Rohs” standards;

Moisture Sensitivity Level: MSL3 (CONDITION: $\cong 30\text{ }^\circ\text{C}/60\%\text{RH}$ 、Time control:168 hours) ;