

Ultra low IQ Synchronous Boost Convertor

General Description

The LP6261 device is a synchronous boost convertor with ultra-low quiescent current. It features a true-shutoff function that disconnects the input and output during shutdown and output short-circuit conditions.

The LP6261 only consumes 1uA quiescent current under light load condition and can achieve up to 75% efficiency at 20uA load. It can achieve up to 93% efficiency at 200mA load from 3.3 V to 5V conversion.

Features

- ◆ 5.1V output voltage
- ◆ Up to 95% efficiency
- ◆ Output to Input Disconnect at Shutdown Mode
- ◆ Shut-down current:<0.1uA
- ◆ Over Output Voltage Protection
- ◆ Over Current Protection
- ◆ Over Temperature Protection
- ◆ Internal Compensation of Soft-start
- ◆ 1.2MHz fixed frequency switching
- ◆ RoHS Compliant and 100% Lead (Pb)-Free

Order Information

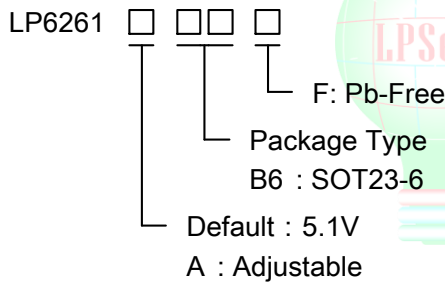

Applications

- ◇ Tablet, MID
- ◇ Smart Phone
- ◇ Power Bank

Typical Application Circuit

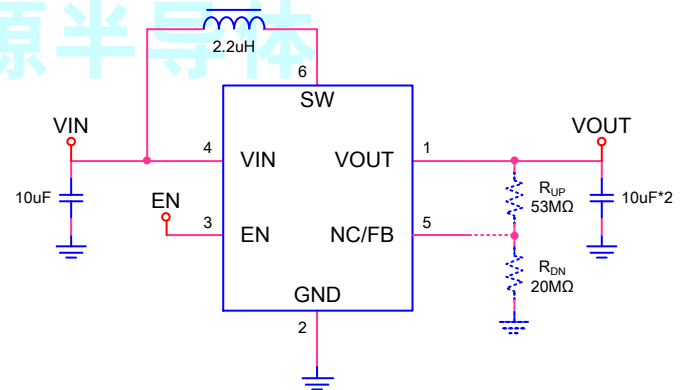

Marking and Package Information

Device	Marking	Package	MSL	Shipping
LP6261B6F	LP6261 YWXXX	SOT23-6	MSL3	3K/REEL
LP6261AB6F	LP6261A YWXXX	SOT23-6	MSL3	3K/REEL

Marking indication:

Y:Production year W:Production week X: Series Number

Functional Pin Description

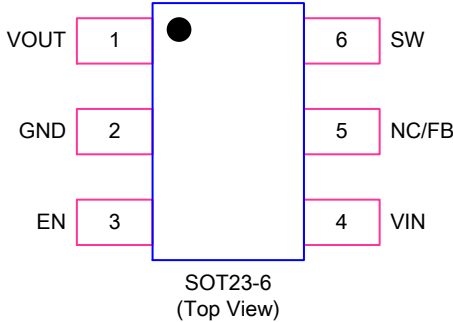
Package Type	Pin Configurations
SOT23-6	 <p style="text-align: center;">SOT23-6 (Top View)</p>

Pin Description

Pin No.	Name	Description
1	VOUT	Voltage output pin.
2	GND	Ground pin.
3	EN	Chip enable pin. Logic high voltage enables the device; logic low voltage disables the device. Do not leave it floating.
4	VIN	Voltage supply input pin.
5	NC (LP6261)	No Connect.
	FB (LP6261A)	Feedback pin. The feedback voltage is 1.36V.
6	SW	Pin for switching.

Function Diagram

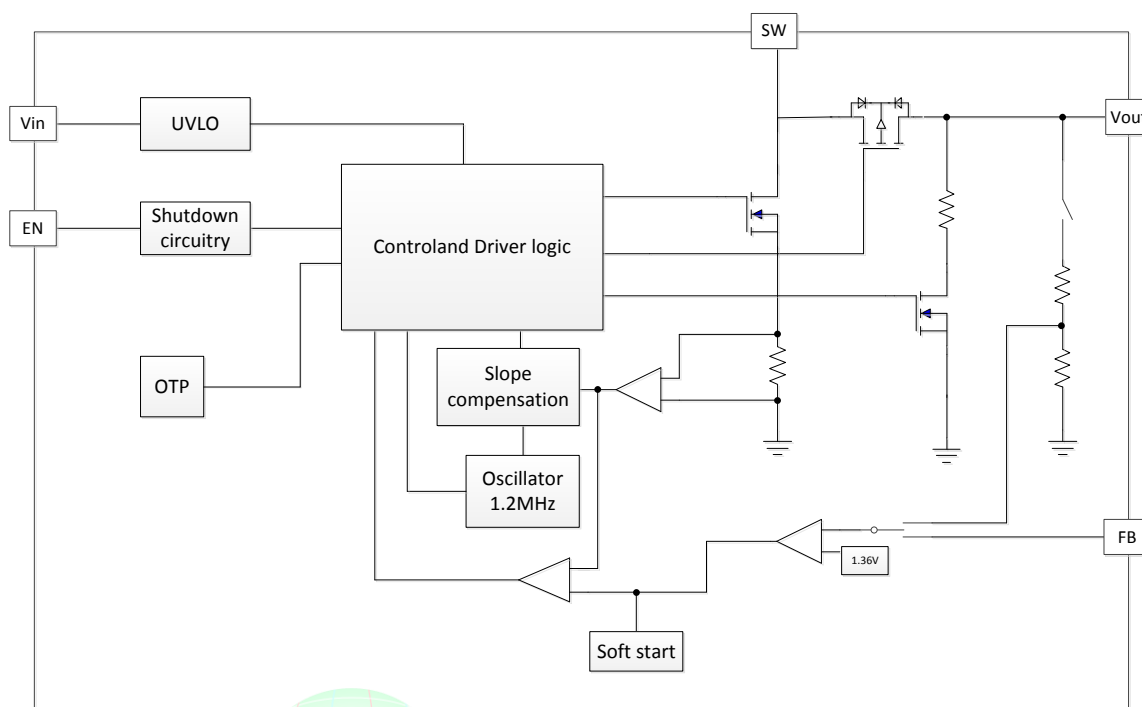

Absolute Maximum Ratings ^{Note 1}

◇ VIN and EN to GND	-----	6.5V
◇ VOUT to GND	-----	8V
◇ SW to GND	-----	9V
◇ Maximum Junction Temperature	-----	150°C
◇ Maximum Soldering Temperature (at leads, 10 sec)	-----	260°C

Note 1. Stresses beyond those listed under “Absolute Maximum Ratings” may cause permanent damage to the device. These are stress ratings only, and functional operation of the device at these or any other conditions beyond those indicated in the operational sections of the specifications is not implied. Exposure to absolute maximum rating conditions for extended periods may affect device reliability.

Thermal Information

◇ Maximum Power Dissipation (SOT23-6, P _D , T _A =25°C)	-----	0.45W
◇ Thermal Resistance (SOT23-6, J _A)	-----	250°C/W

ESD Susceptibility

◇ HBM(Human Body Mode)	-----	2KV
◇ MM(Machine Mode)	-----	200V

Recommended Operating Conditions

◇ Ambient Temperature Range	-----	-20°C to 85°C
-----------------------------	-------	---------------

Electrical Characteristics

($V_{IN}=3.5V$, $V_{OUT}=5V$, $C_{IN}=10\mu F$, $C_{OUT}=22\mu F$, $L=2.2\mu H$)

Parameter	Condition	Min	Typ	Max	Units
Output Voltage	LP6261B6F	5.0	5.1	5.2	V
Feedback Voltage	LP6261AB6F	1.333	1.36	1.388	V
Supply Voltage		2		5	V
Input UVLO	$I_{OUT}=1mA$		0.8		V
Supply Current	$V_{EN}=High$, $V_{IN}=5V$, No load		1	5	μA
Supply Current(Shutdown)	$V_{EN}=0V$, $V_{IN}=5V$		0.05	1	μA
Switching Frequency			1200		KHz
EN Input Low Voltage				0.3	V
EN Input High Voltage		1.4			V
EN Input Current	$V_{EN}=5V$		0.1		μA
Low-side Current Limit	$V_{IN}=3.5V$		1		A
Star-up Current Limit			1		A
High-side On Resistance	$I_{DS}=-100mA$		160		$m\Omega$
Low-side On Resistance	$I_{DS}=100mA$		220		$m\Omega$
Output Discharge Resistance	$V_{OUT}=5V$, $V_{EN}=0V$		2		$K\Omega$
Thermal Shutdown			150		$^{\circ}C$
Thermal Shutdown Hysteresis			25		$^{\circ}C$

Application Curves

($C_{IN}=10\mu F$, $C_{OUT}=22\mu F$, $L=2.2\mu H$)

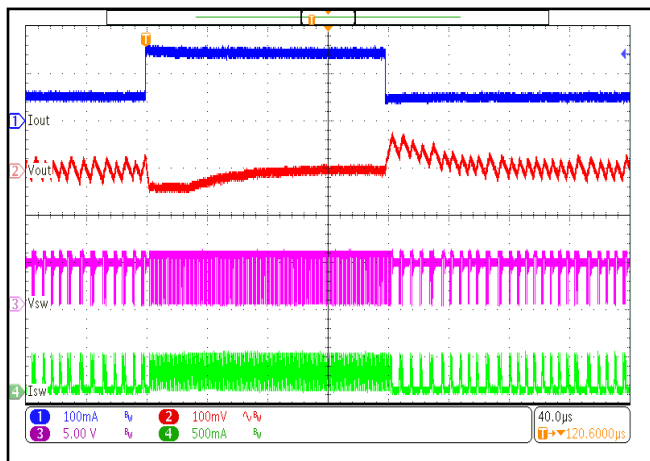

$V_{IN}=4.2V$, $I_{OUT}=50mA$ to $150mA$

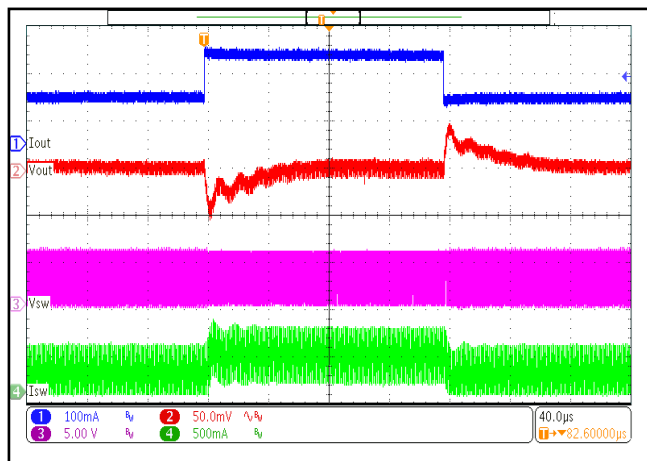

$V_{IN}=4.2V$, $I_{OUT}=100mA$ to $200mA$

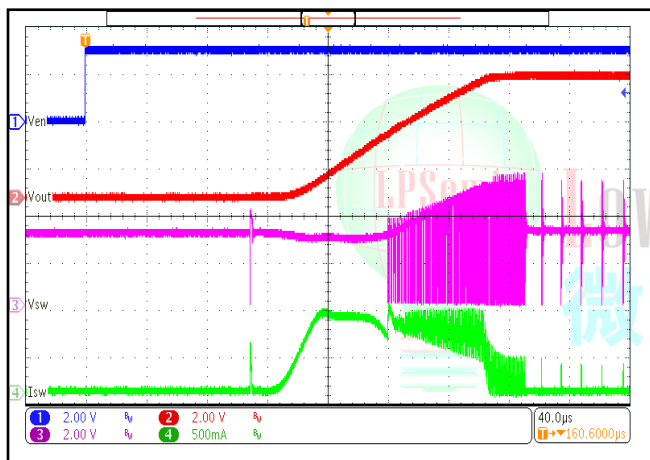

$V_{IN}=3V$, No Load

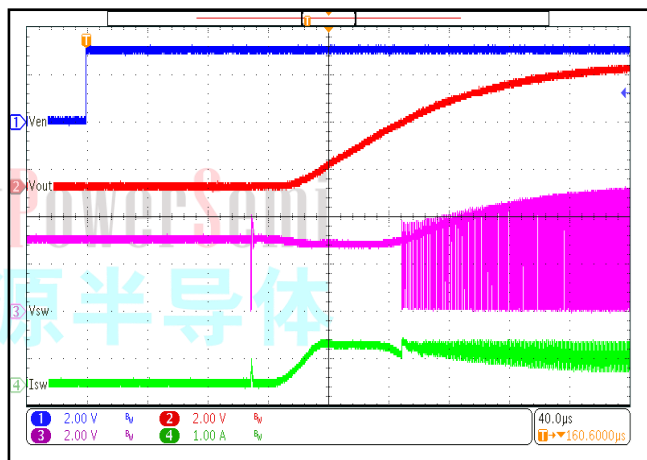

$V_{IN}=3V$, $R_{LOAD}=20\Omega$

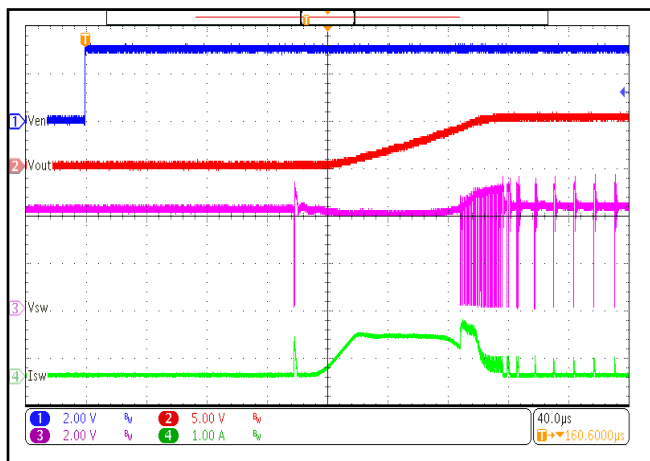

$V_{IN}=4.2V$, No Load

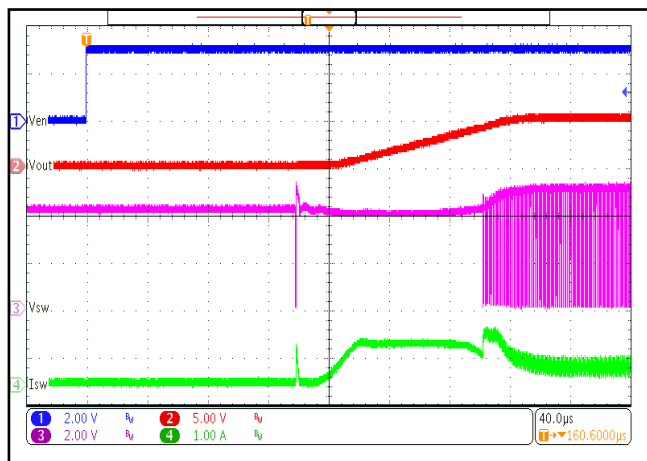

$V_{IN}=4.2V$, $R_{LOAD}=20\Omega$

Typical Operating Characteristics

($C_{IN}=10\mu F$, $C_{OUT}=22\mu F$, $L=2.2\mu H$)

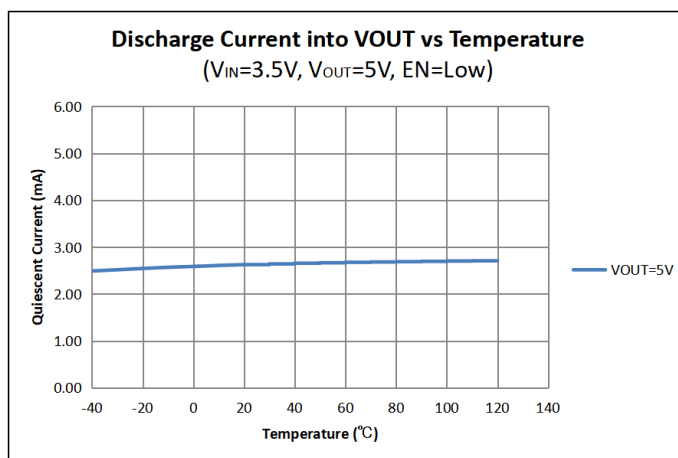
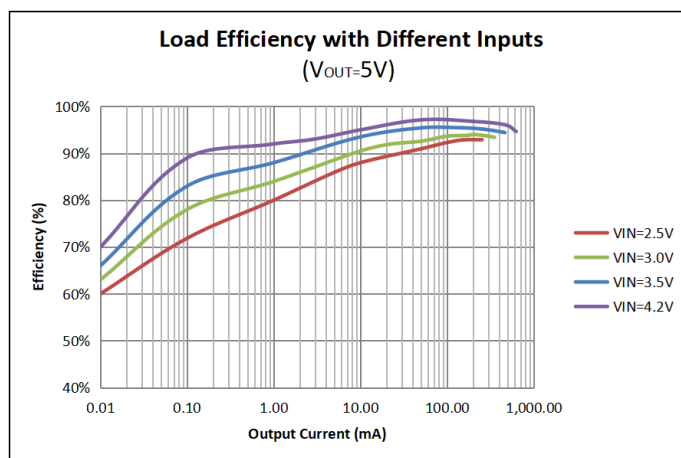
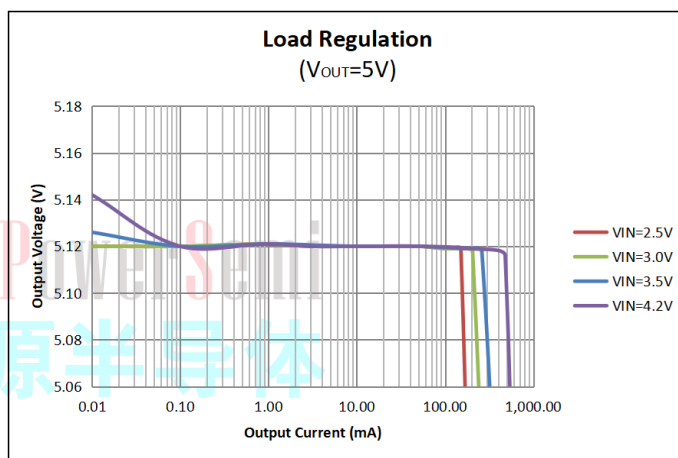
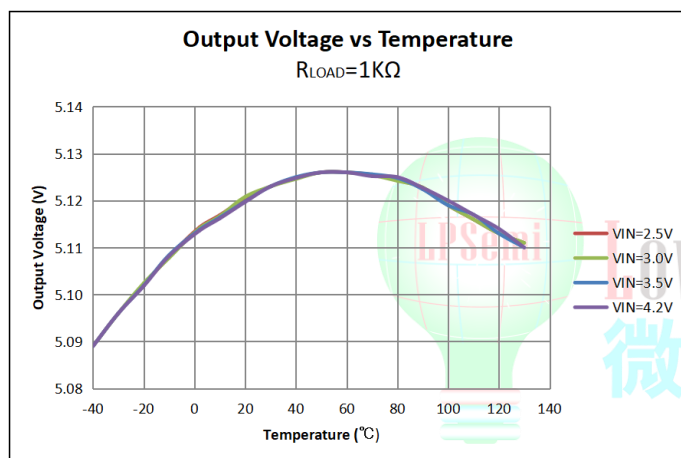
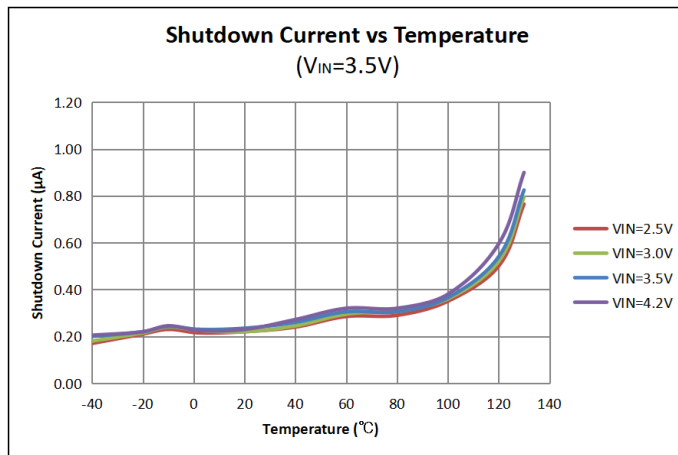
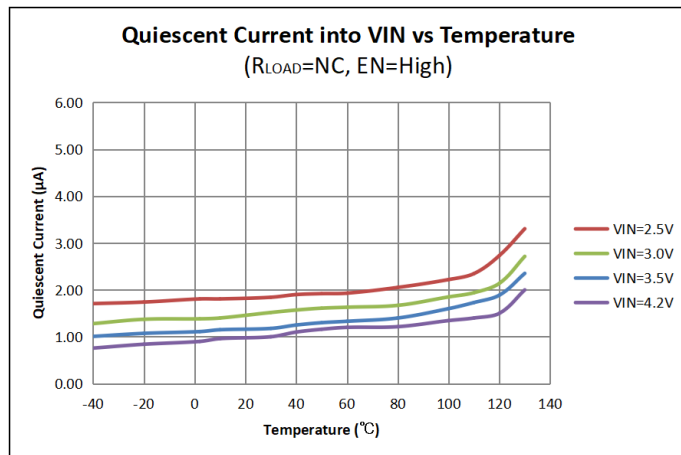

Application Information

The LP6261 uses a synchronous 1.2MHz fixed frequency with 1uA ultra-low quiescent current. It is designed for alkaline battery, coin-cell battery, Li-ion or Li-polymer battery powered systems, which requires long battery running time and tiny solution size.

The LP6261 uses cycle-by-cycle overcurrent protection. If the inductor peak current reaches the current limit, the chip turns off the main switch to stop the further increase in input current. In this case, the output voltage will decrease until the power balance between the input and output is reached.

Short-Circuit Protection

Unlike most boost converters, the LP6261 allows output shorts. In the case of a short circuit, the LP6261 first turns off the NMOS when the current detected by the chip reaches the current limit. When V_{OUT} falls below V_{IN} , the device enters a linear mode of operation with the same current limit as the start-up period. In addition, the thermal shutdown circuits disable switching if the die temperature rises above 150°C.

Setting the Output Voltage

Set the output voltage by selecting the resistive voltage divider ratio. The voltage divider drops the output voltage to the 1.36V feedback voltage. Determine the resistor R_{UP} and R_{DN} by the following equation:

$$V_{OUT} = \left(\frac{R_{UP}}{R_{DN}} + 1 \right) \times V_{FB}$$

Layout Guide

For high frequency switching power supplies, the PCB layout is important step in system application design. In order to let IC achieve good regulation, high efficiency and stability, it is strongly recommended the power components (Inductor, input and output capacitor) should be placed as close as possible to chip. The set traces should be wide and short.

Packaging Information

SOT23-6

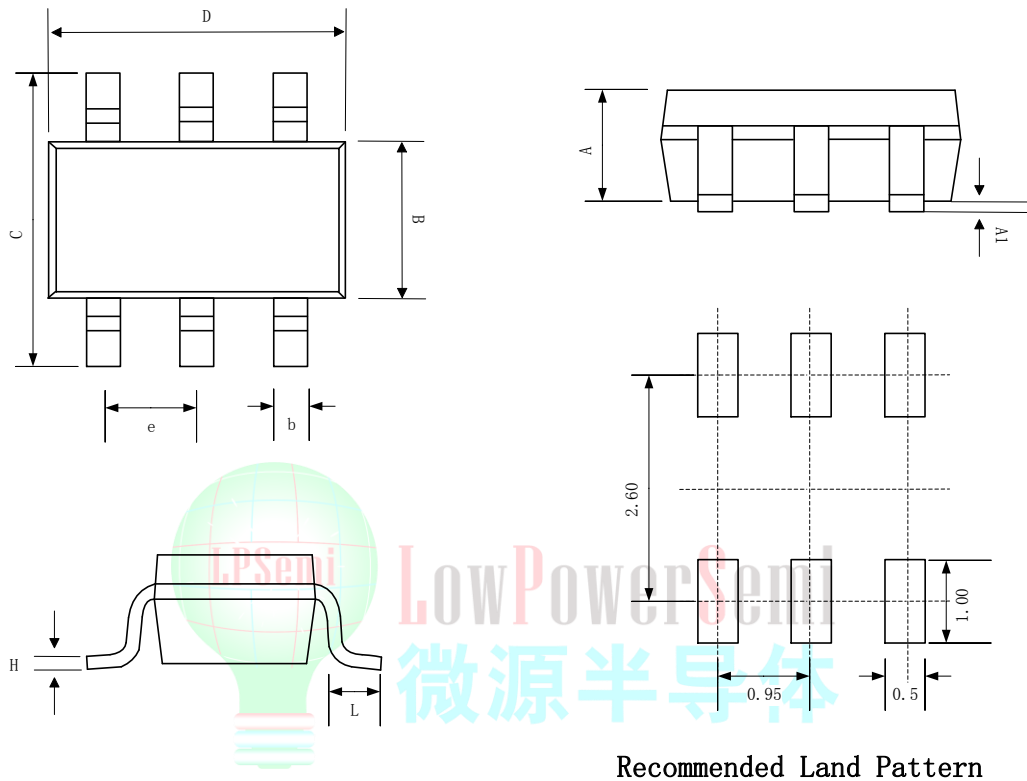

Recommended Land Pattern

SYMBOL	MILLIMETER		
	MIN	NOM	MAX
A	0.889	1.100	1.295
A1	0.000	0.050	0.152
B	1.397	1.600	1.803
b	0.28	0.35	0.559
C	2.591	2.800	3.000
D	2.692	2.920	3.120
e	0.95BSC		
H	0.080	0.152	0.254
L	0.300	0.450	0.610