

One Cell Li-Ion Battery Protection IC

General Description

The LPB1001 product is a highly integrated solution for Li-Ion battery protection. It includes advanced power MOSFETs, precision voltage detection circuitry and delay circuitry for all the protection functions required in battery applications, including overcharge, overdischarge, overcurrent and load short circuit protection. Its accurate overcharge detection voltage ensures a safe and efficient charging cycle. The low standby current allows for almost no battery current to be consumed during storage.

The LPB1001 is available in an ultra-small TDFN-4 package. Its simple peripheral circuit requires only one external capacitor.

This chip is suitable for any electronic device that requires long-term continuous power supply from a Li-Ion battery.

Features

- ◆ Protection of Battery Cell Reverse Connection
- ◆ Over-temperature Protection
- ◆ Integrate Advanced Power MOSFET with Equivalent of 70mΩ R_{DS(ON)}
- ◆ Two-step Overcurrent Detection:
 - Overdischarge Current
 - Load Short Circuiting
- ◆ Overcharge Current Protection
- ◆ 0V Battery Charging Function
- ◆ Delay Times are generated inside
- ◆ High-accuracy Voltage Detection
- ◆ Low Current Consumption:
 - Operation Mode: 1.5μA typ.

Typical Application Circuit

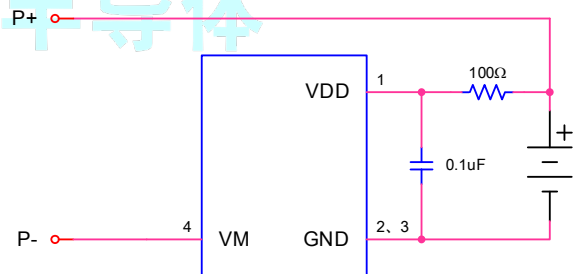

Order Information

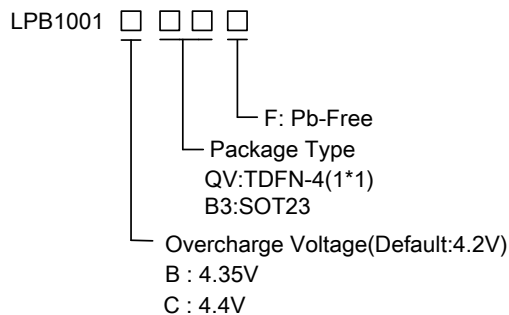

Applications

- ✧ Any application that requires long periods of power from a Li-Ion battery

Marking Information

Device	Marking	Package	Shipping
LPB1001QVF	YWX	TDFN-4(1*1)	12K/REEL
LPB1001BQVF			
LPB1001CQVF			
LPB1001B3F	LPS J1YWX	SOT23	3K/REEL
Marking indication: Y:Production year W:Production week X:Production batch.			

Functional Pin Description

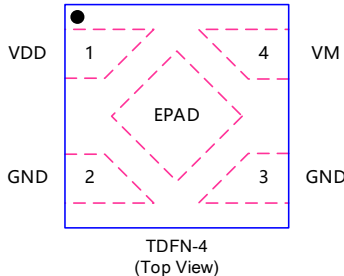
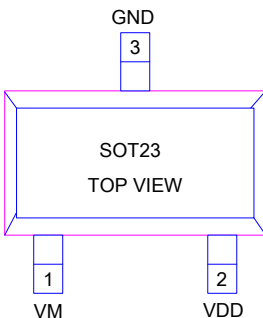
Package Type	TDFN-4(1*1)	SOT23
Pin Configurations	 <p>TDFN-4 (Top View)</p>	 <p>SOT23 TOP VIEW</p>

Pin Description

Name	Pin		Description
	TDFN-4	SOT23	
GND	2、3	3	Ground, connect the negative terminal of the battery to this pin
VDD	1	2	Power Supply
VM	4	1	The internal FET switch connects this terminal to GND
NC	EPAD		Not Use, Suggest to connect with GND

Function Diagram

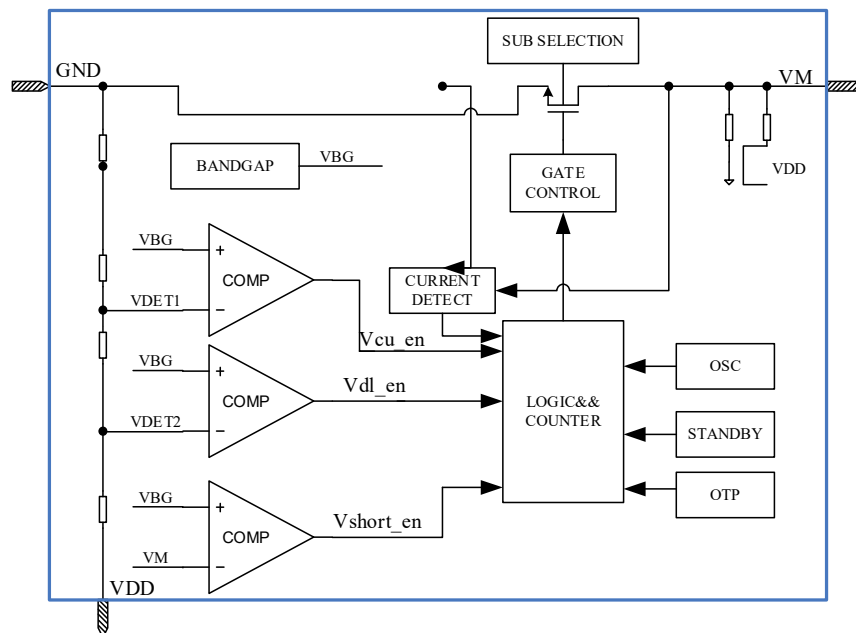

Absolute Maximum Ratings ^{Note 1}

- ✧ VDD to GND ----- -0.3V to 6V
- ✧ VM to GND ----- VDD-6V to VDD+0.3V

Note 1. Stresses beyond those listed under “Absolute Maximum Ratings” may cause permanent damage to the device. These are stress ratings only, and functional operation of the device at these or any other conditions beyond those indicated in the operational sections of the specifications is not implied. Exposure to absolute maximum rating conditions for extended periods may affect device reliability.

Recommended Operating Conditions

- ✧ Operating Ambient temperature ----- -40°C to +85°C
- ✧ Storage temperature ----- -55°C to +125°C
- ✧ Maximum Junction Temperature ----- +125°C

Thermal Information

- ✧ Maximum Power Dissipation (TDFN-4, PD, TA=25°C) ----- 390mW
- ✧ Thermal Resistance (TDFN-4, θ_{JA}) ----- 256°C/W

ESD Susceptibility

- ✧ HBM(Human Body Mode) ----- 2KV
- ✧ MM(Machine Mode) ----- 200V

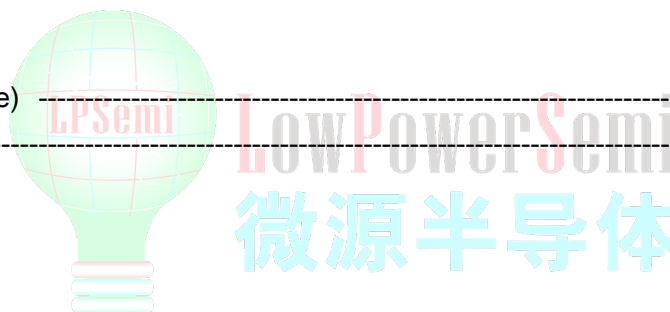

Electrical Characteristics

(Typicals and limits appearing in normal type apply for TA = 25°C, unless otherwise specified.)

Parameter	Symbol	Condition	Min	Typ	Max	Unit
Current Consumption						
Current Consumption in Normal Operation	I _{OPE}	V _{DD} =3.6V		1.5	3	μA
Current Consumption in power Down	I _{PDN}	V _{DD} =2V		0.1		μA
Detection Voltage						
Overcharge Detection Voltage	V _{CU}	LPB1001QVF	4.28	4.325	4.37	V
		LPB1001BQVF	4.43	4.475	4.52	V
		LPB1001CQVF	4.48	4.525	4.57	V
Overcharge Release Voltage	V _{CL}	LPB1001QVF		4.10		V
		LPB1001BQVF		4.25		V
		LPB1001CQVF		4.30		V
Overdischarge Detection Voltage	V _{DL}		2.75	2.8	2.85	V
Overdischarge Release Voltage	V _{DR}			3.0		V
Detection Current						
Overdischarge Current Detection	I _{IOV1}	V _{DD} =3.6V		1		A
Overcharge Current Detection	I _{CHOC}	V _{DD} =3.6V		1		A
Load Short-Circuiting Detection	*I _{SHORT}	V _{DD} =3.6V		3		A
Delay time						
Overcharge Voltage Detection Delay Time	t _{CU}	V _{DD} =3.6V~4.4V		100		mS
Overdischarge Voltage Detection Delay Time	t _{DL}	V _{DD} =3.6V~2.0V		25		mS
Overcharge Current Detection Delay Time	t _{CHOC}	V _{DD} =3.6V	2	12	20	mS
Overdischarge Current1 Detection Delay Time	t _{IOV1}	V _{DD} =3.6V	2	12	20	mS
Load Short-circuiting Detection Delay Time	*t _{SHORT}	V _{DD} =3.6V	100	150	400	uS
VM Internal Resistance						
Internal Resistance between VM and VDD	R _{VMD}	V _{DD} =2.0V VM pin floating		450		kΩ
Internal Resistance between VM and GND	R _{VMS}	V _{DD} =3.6V VM=1V		1.4		kΩ
FET on Resistance						
MOS transistor on-resistance	R _{D(S)ON}	V _{DD} =3.6V, I _D =1.0A		70		mΩ
Over Temperature Protection						
Over Temperature Protection	*T _{SHD+}			125		°C
Over Temperature Recovery Degree	*T _{SHD-}			95		°C
Charger Voltage (0V charging)	V _{0CHA}		1.2			V

Application Information

LPB1001 has functions such as overcharge voltage protection, overdischarge voltage protection, overdischarge current protection, overcharge current protection and short circuit to operate the battery within the specified range. The chip only requires an external capacitor. MOSFET is integrated, and its $R_{DS(ON)}$ typical value is as low as 70m Ω

Normal operating mode

LPB1001 monitors the battery voltage connected between the VDD pin and the GND pin and the voltage difference between the VM pin and the GND pin to control charging and discharging. When the battery voltage is within the range of over-discharge detection voltage (V_{DL}) to over-charge detection voltage (V_{CU}), LPB1001 will turn on the charge and discharge control FET at the same time. Under no special test conditions, it can be charged and discharged freely. This state called the normal operating mode.

Overcharge Condition

Under normal charging process, when the battery voltage is higher than the overcharge detection voltage (V_{CU}) and the detection continues for the overcharge detection delay time (t_{CU}) or longer, the LPB1001 will turn off the charging control FET to stop the charging. This situation is called overcharge condition.

The release mechanism of the overcharged condition is described in the following 2 points:

1. When the battery voltage is lower than the overcharge release voltage (V_{CL}), LPB1001 will turn on the charging control FET to release the overcharge condition.

2. When a load is connected and discharging starts, the LPB1001 turns the charging control FET on and returns to the normal condition. The release mechanism is as follows: After detecting overcharge, when the load is connected to start discharging, the discharge current flows through the parasitic diode in the charge control FET, the VM pin voltage rises more than the GND pin voltage due to the V_f voltage of the parasitic diode. If the voltage of the VM pin is higher than or equal to the discharge overcurrent detection voltage (V_{DIOV}), therefore, when the battery voltage is lower than or equal to the overcharge detection voltage (V_{CU}), the LPB1001 will release the overcharge condition.

Even if a heavy load is connected, if the battery voltage is higher than the overcharge detection voltage (V_{CU}) and the battery voltage does not fall below the overcharge detection voltage (V_{CU}), discharge overcurrent detection and load short-circuiting detection do not work until the battery voltage falls below overcharge detection voltage (V_{CU}).

Overdischarge Condition

Under normal discharging process, when the battery voltage is lower than the overdischarge detection voltage (V_{DL}) and the detection continues for the overdischarge detection delay time (t_{DL}) or longer, the LPB1001 will turn off the discharge control FET to stop the discharge. This situation is called overdischarge condition.

Under this condition, the current consumption will be reduced to the power-down current consumption (I_{PDN}). This situation is called a power-down condition.

The resistor (R_{VMS}) between VM pins and GND pins is not connected under this condition and overdischarge condition. When the charger is connected, the power-down condition will be released and the voltage difference between VM pins and VDD pins becomes a typical 1.2V value, or higher. At this point, the FET is still off. When the battery voltage is equal to or greater than the overdischarge detection voltage (V_{DL}), LPB1001 conducts the FET from the overdischarge condition to the normal condition.

Discharge Overcurrent Condition

In the normal condition, the discharge current is higher than the specified value (VM pin voltage is equal to or higher than the discharge overcurrent detection voltage), and the condition lasts for the discharge overcurrent detection delay time, the LPB1001 will turn off the discharge control FET to stop the discharge. This situation is called the discharge overcurrent condition.

In the discharge overcurrent condition, a short circuit occurs through the resistance (R_{VMS}) between the VM terminal and the GND terminal. However, as long as the load is connected, the VM pin voltage is equal to the VDD potential. After removing the load, the VM pin will return to the GND potential. If is detected to the VM pin voltage return to the discharge overcurrent detection voltage (V_{DIOV}) or lower, the IC returns to the normal condition.

Charge Overcurrent Detection

In the normal condition, the charge current is higher than the specified value (VM pin voltage is lower than the charge overcurrent detection voltage), and it continues for the overcharge detection delay time,

the LPB1001 will turn off the charge control FET to stop the charge. This situation is called the charge overcurrent condition.

By removing the charger, when the VM pin voltage returns to the charge overcurrent detection voltage (V_{CIOV}) or higher, the LPB1001 will return from the charge overcurrent condition to the normal condition.

In the overdischarge condition, the charge overcurrent detection function does not work. In the overdischarge condition, the charge overcurrent detection function does not work as the resistor (R_{VMD}) between the VM pin and VDD pin and the resistor (R_{VMS}) between the VM pin and GND pin are not connected.

Load Short-circuiting condition

If voltage of VM pin is equal or greater than the short circuiting protection voltage (V_{SHORT}) and the duration exceeds the short-circuit delay time t_{SHORT} , the LPB1001 will stop discharging and disconnect the battery from the load. This condition is released when voltage of VM pin is below short protection voltage (V_{SHORT}), such as when disconnecting the load.

Delay Circuits

When the discharge overcurrent detection voltage (V_{DIOV}) is detected, the discharge overcurrent detection delay time (t_{DIOV}) and load short-circuit detection delay time (t_{SHORT}) are started. After the discharge overcurrent detection voltage (V_{DIOV}) is detected, if the load short-circuit detection voltage (V_{SHORT}) is detected within the load short-circuit detection delay time (t_{SHORT}), the LPB1001 turns the discharging control FET off within the load short-circuiting detection delay time (t_{SHORT}) from the

time of detecting V_{SHORT} .

When an overcurrent is detected and the overcurrent duration exceeds the overdischarge detection delay time (t_{DL}) without releasing the load, and when the battery voltage drops below the overdischarge detection voltage (V_{DL}), the state will change to the power-down condition in the following time. When the battery voltage drops below the overdischarge detection voltage (V_{DL}) due to overcurrent, the LPB1001 will turn off the discharge control FET through overcurrent detection. In this case, the LPB1001 will switch to the power-down condition because the battery voltage recovery is so slow that the battery voltage after the overdischarge detection delay time (t_{DL}) is still lower than the overdischarge detection voltage (V_{DL}).

0V Battery Charging Function ⁽¹⁾ ⁽²⁾ ⁽³⁾

This function is used to charge a connected battery whose voltage is 0 V caused by self-discharge. When the 0 V battery charge starting charger voltage (V_{OCHA}) or a higher voltage is applied between the P+ and P- pins by connecting the charger, the gate of the charge control FET is fixed to the VDD pin voltage. When the voltage between the gate and source of the charge control FET becomes equal to or higher than the turn-on voltage due to the charger voltage, the charge control FET turns on to start charging. At this time, the discharging control FET is off and the charging current flows through the internal parasitic diode in the discharging control FET. If the battery voltage becomes equal to or higher than the overdischarge release voltage (V_{DU}), the LPB1001 enters normal condition.

Note:

(1) Some battery suppliers do not recommend

charging fully self-discharged batteries. Please refer to the battery supplier to determine whether to enable or disable the 0V battery charging function.

(2) The priority of 0V battery charging function is higher than charging overcurrent detection function. Therefore, products with 0V battery charging enabled will force the battery to be charged, and when the battery voltage is lower than the overdischarge detection voltage (V_{DL}), the charging overcurrent cannot be detected.

(3) When a battery is connected to the IC for the first time, the IC may not enter the normal condition in which discharging is possible. In this case, set the VM pin voltage equal to the GND voltage (short the VM and GND pins or connect a charger) to enter the normal condition.

Packaging Information

TDFN-4

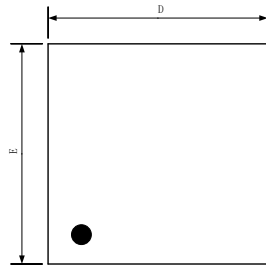

TOP VIEW

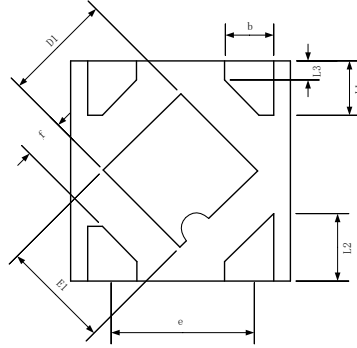

BOTTOM VIEW

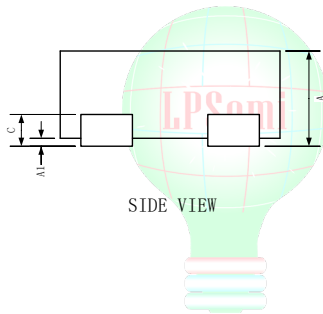

SIDE VIEW

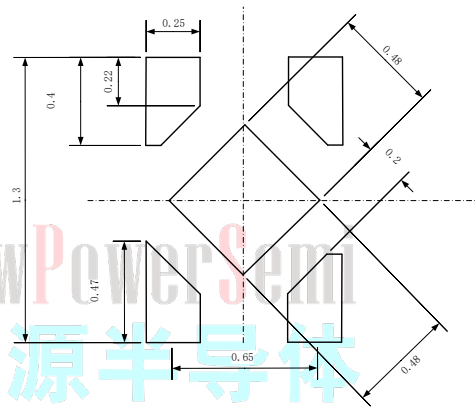

Recommended Land Pattern

SYMBOL	MILLIMETER		
	MIN	NOM	MAX
A	0.35	-	0.40
A1	0.00	0.02	0.05
b	0.20	0.25	0.30
c	0.07	0.12	0.17
D	0.95	1.00	1.05
D1	0.43	0.48	0.55
E	0.95	1.00	1.05
E1	0.43	0.48	0.55
e	0.65BSC		
L1	0.2	0.25	0.30
L2	0.27	0.32	0.37
L3	0.09REF		
f	0.18REF		



SOT23

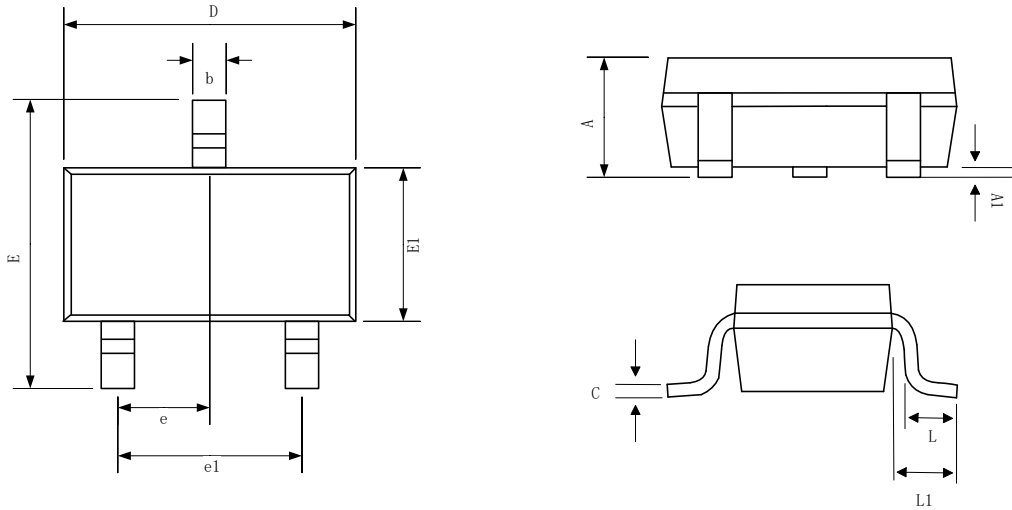

SYMBOL	MILLIMETER		
	MIN	NOM	MAX
A	0.900		1.200
A1	0.000	0.050	0.100
b	0.300	0.400	0.500
c	0.008	0.120	0.150
D	2.800	2.900	3.000
E	2.250	2.400	2.550
E1	1.200	1.300	1.400
e	0.950BSC		
e1	1.900BSC		
L	0.200	0.350	0.500
L1	0.550REF		