



Features

- Maximum input voltage up to 30-V with 15-V input-over-voltage protection
- Charge management
 - Maximum charge current up to 350-mA
 - Default 4.2-V floating voltage with 1% accuracy
 - Trickle current/constant current/constant voltage mode supported
 - Charge termination and automatic re-charge
 - Dynamic power management for different input source capacity application
- Discharge management
 - Smart discharge voltage management to maximize the battery life
 - 96% peak boost efficiency
 - Automatic load detection
 - Key control
 - Low cut-off discharge current
 - Inductor current-limit protection
 - Short circuit protection
- Temperature Management
 - Thermal foldback at 125°C junction temperature
 - Thermal shutdown at 150°C junction temperature
- Built-in charging and discharging indication
- 20-µA low quiescent current in standby mode

Applications

- TWS charging case

Order Information

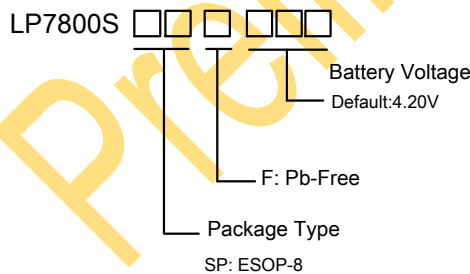

General Description

The LP7800S is an advanced TWS charging case management IC targeting to improve the total battery run time of the TWS earphones. The IC integrates a linear charger which contains completely charge modes with up to 350-mA charge current, and a smart discharge management module to protect the battery from over-discharged to maximize the battery run time. The IC features a high efficiency synchronous boost module, automatic load detection and Key control discharge, automatic shut-down while the discharge current is lower than the cut-off current threshold. The IC includes charging and discharging status indication through two LEDs controller. The quiescent current is less than 20-µA in standby mode.

The device provides various safety features for battery charging and discharging, including device junction temperature-limit protection for charging by limiting the charge current, which is implemented by an internal thermal foldback regulation loop, battery discharge inductor current-limit protection, V_{OUT} short protection and thermal shutdown.

The LP7800S is available in a small 8-pin ESOP package.

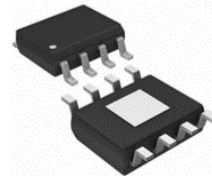

Marking Information

Device	Marking	Package	Shipping
LP7800SSPF	LPS LP7800S YWX	ESOP-8	4K/REEL
Marking indication: Y: Year code. W: Week code. X: Batch numbers.			



Typical Application Circuit

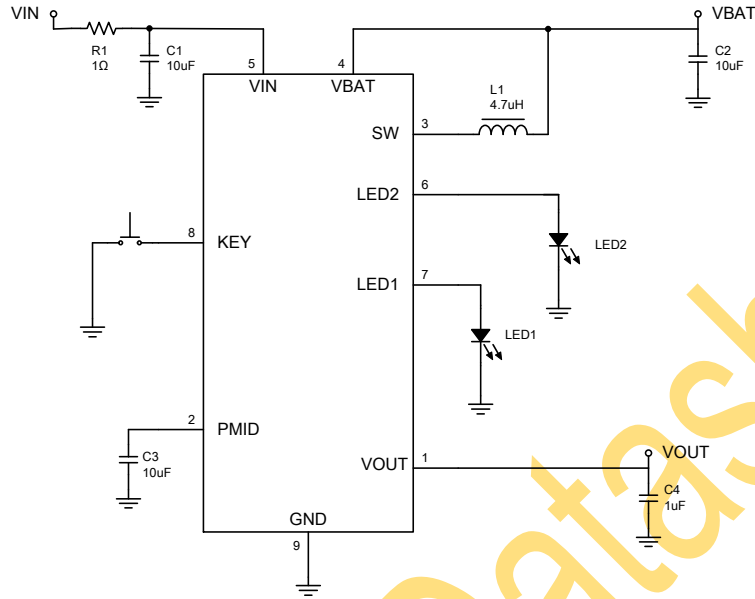

Pin Diagram

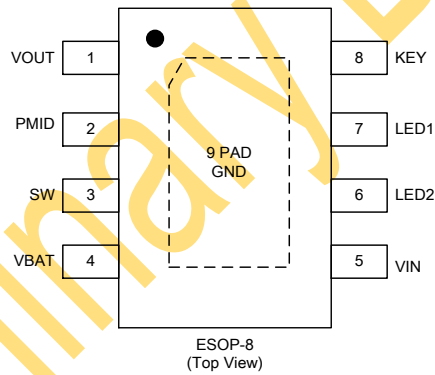



Pin Description

Pin No.	Name	Description
1	VOUT	Discharge Output. Connect the pin with a 1- μ F capacitor to GND.
2	PMID	Boost Module Output. Connect the pin with a 10- μ F capacitor to GND.
3	SW	Boost Module Switching Pin. Connect this pin with an inductor.
4	VBAT	Battery Pin. Connect to the charging output and discharge input internally.
5	VIN	Input Supply Source. Connect to a wall adaptor typically.
6	LED2	Discharging Indicator.
7	LED1	Charging Indicator.
8	KEY	KEY Control Pin.
9(PAD)	GND	Ground.

Functional Block Diagram

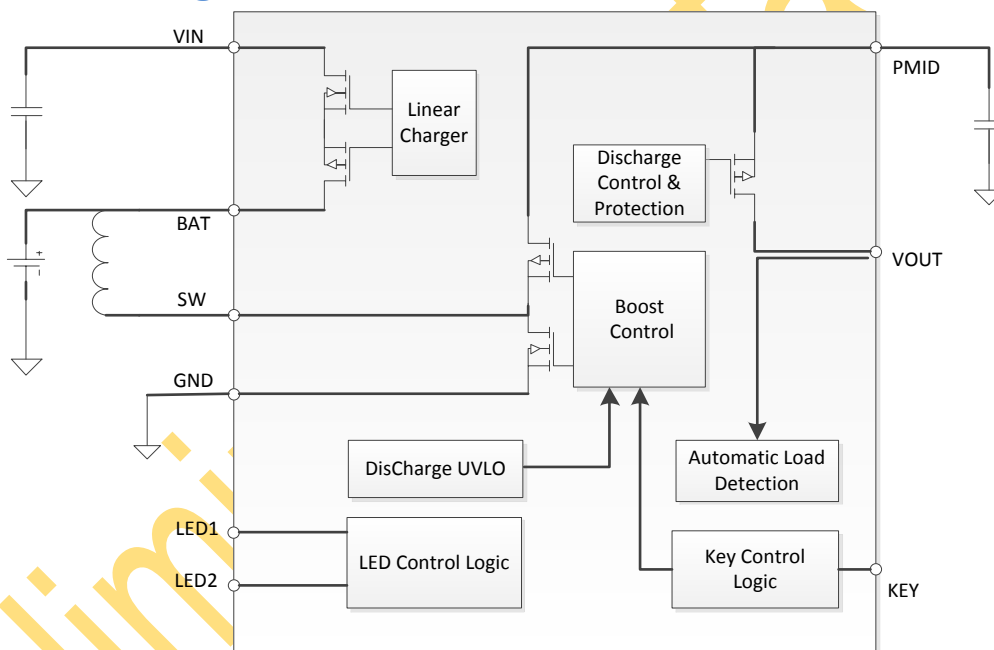



Absolute Maximum Ratings (Note 1)

- VIN to GND ----- -0.3V to 30V
- SW to GND ----- -0.3V to 9V
- Other Pin to GND ----- -0.3V to 7V
- Maximum Power Dissipation (P_D , $T_A=25^\circ\text{C}$) ----- 1.5W
- Maximum Junction Temperature (T_J) ----- 150°C
- Storage Temperature ----- -55°C to 150°C
- Maximum Soldering Temperature (at leads, 10 sec) ----- 260°C

Note 1. Stresses beyond those listed under “Absolute Maximum Ratings” may cause permanent damage to the device. These are stress ratings only, and functional operation of the device at these or any other conditions beyond those indicated in the operational sections of the specifications is not implied. Exposure to absolute maximum rating conditions for extended periods may affect device reliability.

ESD Susceptibility

- HBM(Human Body Model) ----- 2kV
- MM(Machine Model) ----- 200V

Recommended Operating Conditions

- Input Voltage ----- 4.5V to 6V
- Maximum Charge Current ----- 350mA
- Maximum Discharge Current ----- 300mA
- Operating Junction Temperature Range (T_J) ----- -40°C to 150°C
- Operating Ambient Temperature Range (T_A) ----- -20°C to 80°C

Preliminary Datasheet



Electrical Characteristics

(The specifications are at $T_A=25^\circ\text{C}$, $V_{IN} = 5\text{V}$, unless otherwise noted.)

Symbol	Parameter	Condition	Min	Typ	Max	Units
Charge Module						
V_{IN}	Input Voltage Range		4.5		6	V
I_{IN}	Input Supply Current	Charge Terminated, $V_{BAT}=4.2\text{V}$		280		μA
V_{UVLO}	Under Voltage Lockout of V_{IN}	V_{IN} Rising		3.7		V
V_{UVLO_HYS}	V_{UVLO} Hysteresis	V_{IN} Falling		270		mV
V_{OVP}	Over-Voltage Protection Threshold Voltage	V_{IN} Rising		15		V
V_{OVP_HYS}	OVP Hysteresis Voltage	V_{IN} Falling		1		V
V_{FLOAT}	Regulated Output (Float) Voltage		-1%	4.2	1%	V
I_{BAT}	Constant Charge Current	Constant Current Mode	315	350	385	mA
		After Terminated, $V_{IN}=5\text{V}$, $V_{BAT}=4.2\text{V}$				-2
I_Q	Quiescent current in standby mode	V_{IN} =Floating, $V_{BAT}=4.2\text{V}$				-20 μA
I_{TRIKL}	Trickle Charge Current	$V_{BAT}<V_{TRIKL}$		100		mA
V_{TRIKL}	Trickle Charge Threshold Voltage	V_{BAT} Rising		2.6		V
V_{TRHYS}	Trickle Charge Hysteresis Voltage	V_{BAT} Falling		200		mV
I_{TERM}	Termination Current Threshold			35		mA
ΔV_{RECHRG}	Battery Recharge Voltage Difference Threshold	$V_{FLOAT} - V_{RECHRG}$		150		mV
I_{STAT}	LED1/LED2 Pin Source Current			2		mA
V_{DPM_THR}	Input Dynamic Power			4.4		V



	Management Voltage Threshold					
T _{J_LIMIT}	Junction Temperature-Limit	Thermal Protection State		125		°C
R _{VIN-VBAT}	VIN to VBAT ON-Resistance	V _{BAT} =3.5V		1.6		Ω
Discharging Module						
PMID	Boost Output voltage		5.0	5.1	5.2	V
V _{OUT}	Standby V _{OUT} Voltage	Standby mode		2.7		V
I _{L_Max}	Load current	Standby mode		30		μA
I _{L_PK}	MosFET (Inductor) Peak Current Limit	V _{BAT} =3.7V		900		mA
F _{SW}	Boost switching frequency	V _{BAT} =3.7V, I _{OUT} =100mA		850		kHz
I _{OUT_OCP}	V _{OUT} Over-Current Protection Threshold	V _{BAT} =3.7V		650		mA
V _{SC_TH}	V _{OUT} Short Circuit Voltage Threshold	V _{BAT} =3.7V		250		mV
I _{CUT-OFF}	Output Cut-off Current Threshold	V _{BAT} =3.7V		4		mA
T _{CUT-OFF}	The Time Interval from Trigger the Cut-off threshold to stop the Boost	V _{BAT} =3.7V		16		s
V _{SD_BAT}	Battery Discharging Shut-down Voltage Threshold	Battery voltage discharging Falling		2.8		V
V _{LV_BAT}	Battery Discharging Low Voltage Threshold	Load detection to start Boost module voltage		3.1		V
T _{OTP}	Thermal Shut-down Temperature Threshold			150		°C
R _{PMID-VOUT}	PMID to VOUT ON-Resistance	V _{BAT} =3.5V, I _{OUT} =200mA		1.15		Ω

Typical Characteristics

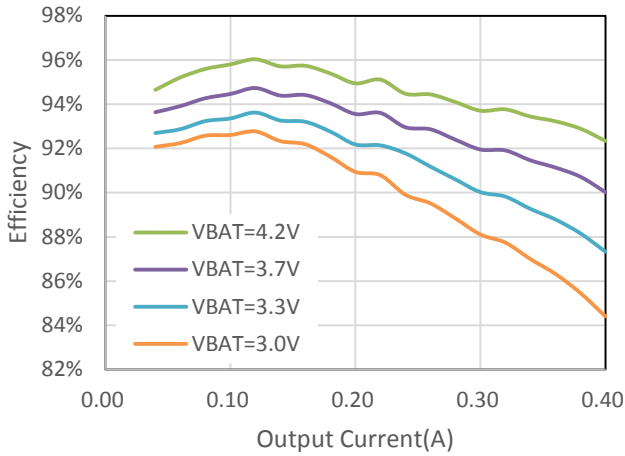

Figure 1. Boost Module VBAT to PMID Efficiency
VIN=Floating, V_{PMID}=5V, 25C°

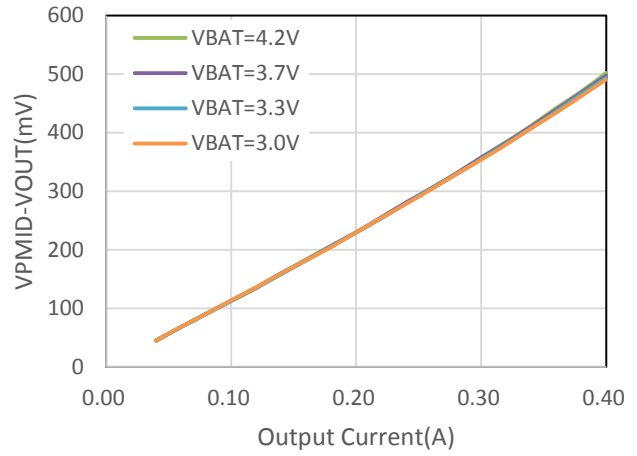

Figure 2. PMID-VOUT voltage vs output current
VIN=Floating, V_{PMID}=5V, 25C°

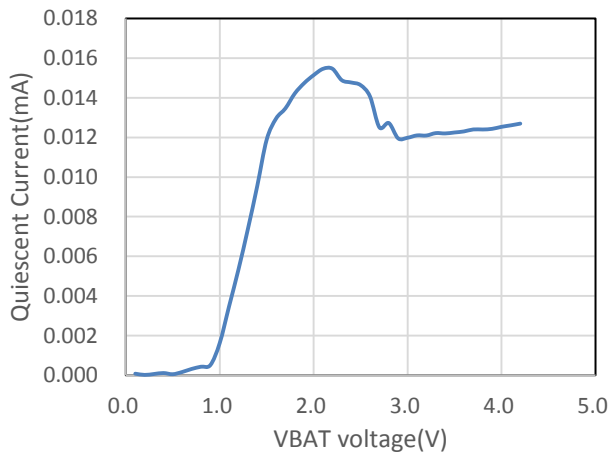

Figure 3. VBAT quiescent current vs VBAT voltage
VIN=Floating, standby mode, 25C°

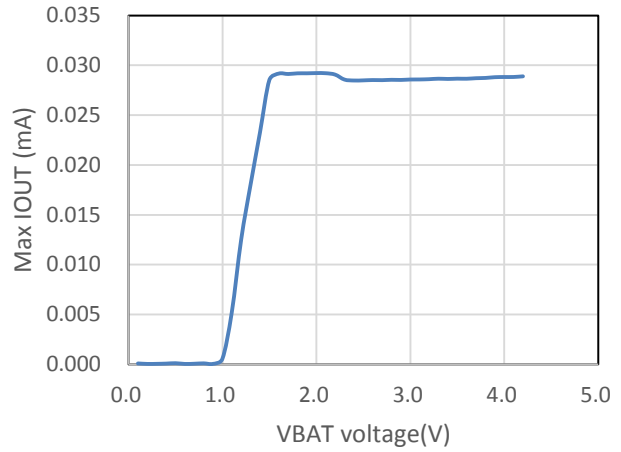

Figure 4. Maximum I_{OUT} at standby mode
VIN=Floating, standby mode, 25C°

Preliminary

Detailed Description

Overview

The LP7800S is an advanced TWS charging case management IC, which integrates a linear charger with 350-mA charge current for single cell Li-Ion and Li-Polymer battery and a synchronous boost discharge management module. The device supports status indicator LEDs, supports charging and discharging simultaneously, includes automatic load detection function. The discharge module can protect the battery and system safety against over-current, short circuit, and over-temperature effectively.

Charging Module

The device charges the battery in three modes: trickle current mode, constant current mode and constant voltage mode.

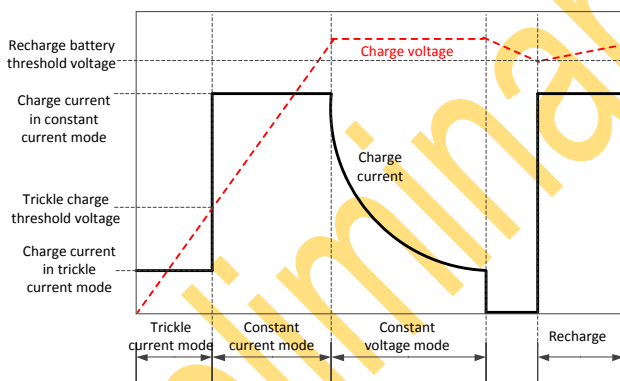

Figure 5. Typical Charge Profile

When the battery voltage is lower than trickle charge threshold voltage 2.6-V (typical), the device is in trickle current mode, the charge current will be set as approximately 100-mA (typical) current to bring the battery voltage up to a safe level for full current charging. When the battery voltage rises to be higher than trickle charge threshold voltage, the device enters

the constant current mode, where the charge current is fixed 350-mA. When the battery voltage approaches the float voltage, the device goes to constant voltage mode, the charge current starts to decrease. When the charge current is lower than the termination current threshold 35-mA typical, the device will terminate the charging. The device will automatically recharge the battery while the battery voltage drops 150-mV (typical, ΔV_{RECHRG}) from the float voltage.

Automatic Recharge

Once the charge cycle is terminated, the LP7800S device continuously monitors the voltage on the BAT pin by a comparator with a 1.95-ms filter. A new charge cycle restarts when the battery voltage drops by a voltage difference ΔV_{RECHRG} 150-mV (typical) from the float voltage, which means the battery level drops to approximately 80% to 90% capacity. This ensures that the battery always keeps at or near a fully charged condition.

Dynamic Power Management

The charging function is always active when plug in a 5V input supply. For different input capacity source application, the LP7800S device integrates an input current adaptive function. When the input voltage falls below the input dynamic power management threshold voltage V_{DPM_THR} as the input source current capacity is not enough to offer the programmed charge current, the device begins to reduce the charge current until the input voltage rising up to about V_{DPM_THR} . When the charge current decreases to zero, but the input voltage is still lower than the V_{DPM_THR} , the device keeps in charge status but has no charge current.



Junction Temperature Protection

An internal thermal foldback loop reduces charge current if the junction temperature attempts to rise above a preset value of approximately 125°C. This function protects the LP7800S from excessive temperature and allows the user to get the limits of the power handling capability of a given circuit board without risk of damaging the LP7800S device. The charge current can be set according to typical ambient temperature with the assurance that the charger will automatically reduce the current in worst-case conditions.

When the junction temperature continues increase to higher than the shutdown temperature threshold 150°C typical, the device will stops all the modules includes charging and discharging.

Discharging Module

LP7800S integrates a synchronous boost module and power MOSFETs for discharging the battery. The PMID is the boost output pin, the output voltage is fixed 5-V while normal discharging. There is a MOSFET between the PMID and VOUT which are used for over-current protection. The boost switching frequency is fixed 850kHz typical.

Automatic Load Detection

The device integrates a 2.7-V voltage source with maximum 30- μ A source current on the VOUT pin at standby mode with no load condition. When insert a load on the VOUT Pin, earphone as an example, there should be current flowed from the voltage source to the load, the device will detect this current, then turn on the boost module and outputs a fixed 5-V voltage on VOUT.

Cut-off Discharging Current Threshold

When the load on the VOUT, earphone as an example, there always be a charger on the load. When the

earphone battery is charged full, the discharge current of the device will decrease, when the discharge current drops to the cut-off discharging current threshold 5-mA typical and lasts for 16 seconds, the boost module will turn off. At this time, the chip will maintain the OUT terminal at the standby voltage of 2.7V, the boost module does not restart again until the next load insertion happened.

Discharge Undervoltage Lockout (UVLO)

LP7800S supports charging and discharging of the battery simultaneously. The device integrates an input undervoltage detection to prevent the battery output large current on the trickle charging current mode at the same time. The feature can protect the battery from over-discharged and acquire as long as possible life run time effectively. When the VBAT drops below 2.8-V, the discharge boost module will be turned off while discharging. When $V_{BAT} < 3.1\text{-V}$, the load detection or KEY click will not automatic start the boost module. Only when $V_{BAT} > 3.1\text{-V}$, the boost function will be active. If the device is on the undervoltage protection state during load detection, after the VBAT voltage rises above 3.1-V, it is necessary to re-detect the load or click the KEY to turn on the boost module.

KEY Control

When the KEY click is detected, and the battery voltage is higher than the discharging UVLO voltage, the boost module turns on and outputs a 5-V voltage and enters discharge mode. If there is no load on the VOUT, the boost module will turn off after 16s.

If the KEY function is not required, keep the KEY pin floating connection.



Short Circuit Protection

If VOUT is shorted to GND when normal discharging, a large current will flow from PMID to VOUT, if the voltage difference from PMID to VOUT is higher than the threshold, the Boost module will turn off. A load insertion detection or KEY click will restart the boost module.

If VOUT is shorted to GND in standby mode, as the standby voltage source has only 30- μ A current capacity, the source voltage will be pulled down to lower than the VOUT short voltage threshold VSC_TH 250-mV typical, then the boost module will not start operating.

LEDs Indication

LED1 indicates the charging status of the device. When the input voltage is above the UVLO and above the battery voltage+150mV ($V_{IN} > V_{BAT} + 150mV$), and lower than OVP ($V_{IN} < V_{OVP}$), the IC is in charging mode, then LED1 pin switches on and off a 2-mA source current in ~1Hz frequency and 50% duty cycle, then the LED light connected from LED1 pin to GND

blinking in ~1Hz frequency. When the battery is charged full and the charging is terminated, the LED1 pin will output 2-mA source current continuously, the LED light keeps on.

Function	LED1 Light
Charging	Blinking in ~1Hz
Battery Full and Charge Terminated	Lights ON
Other Status	Lights OFF

LED2 indicates the discharging status of the device. When the VBAT voltage is higher than the UVLO and detect the load insertion or KEY clicked, the discharge module will operate and output the power from the battery to the load, then LED2 pin will output a 2-mA source current and lights on the LED light. When the VBAT voltage is discharging to trigger the UVLO, the light connected from LED2 Pin will blinking in ~1Hz frequency.

Function	LED2 Light
Discharging	Lights ON
Discharge UVLO	Blinking in ~1Hz
Other Status	Lights OFF



Application Information

Thermal Consideration

The reason which causes the LP7800S device to reduce charge current through thermal foldback loop is the power dissipation of the device. Nearly all of the power dissipation is generated by the internal MOSFETs, the power dissipation can be calculated approximately:

$$P_D = (V_{IN} - V_{BAT}) \times I_{BAT}$$

Where P_D is the power dissipation, V_{IN} is the input supply voltage, V_{BAT} is the battery voltage and I_{BAT} is the charge current. The approximate ambient temperature which the thermal feedback begins to protect the device can be calculate as:

$$T_A = 125^\circ\text{C} - P_D \times \theta_{JA}$$

Due to the low efficiency of linear charging, the most important factors are thermal design and cost, which are a direct function of the input voltage, output charge current and thermal impedance between the battery charger and the ambient cooling air. The worst-case situation is when the device has transitioned from the trickle current mode to the constant current mode. In this situation, the battery charger has to dissipate the maximum power.

In this case, with a maximum 15V input voltage source, 350-mA constant current, the max power dissipation could be:

$$P_{Dmax} = (15V - 2.6V) \times 350\text{mA} = 4.3\text{W}$$

This power dissipation with the battery charger in the ESOP-8 package may cause thermal regulation to decrease the charge current. Then a trade-off must be made between the charge current, cost and thermal requirements of the charger.

Boost Inductor Selection

Because the selection of inductor affects boost module's steady state operation, transient behavior, loop stability and the efficiency, the inductor is one of the most important components in the application design. There are three specifications most important to the performance of the inductor: inductor value, DC resistance, and saturation current. For the LP7800 device applications, a 2.2 ~4.7 μH inductor is typically available. Therefore, customers need to verify the inductor in their application if it is different from the values in typical application circuit. Inductor values can have $\pm 20\%$ or even $\pm 30\%$ tolerance with no current bias. When the inductor current approaches saturation level, its inductance can decrease 20% to 35% from the 0A value depending on how the inductor vendor defines saturation. When selecting an inductor, please make sure its rated current, especially the saturation current, is larger than its peak current during the operation. To calculate the inductor peak current in the worst case, customers need take consideration of the minimum boost input voltage (in this case, it should be the V_{SD_BAT}) and maximum discharging current of the application. In order to leave enough design margin, the inductor value with -30% tolerance is recommended for the calculation. In a boost switching charger, the inductor maximum DC current should be the discharging output current. The inductor peak current can be calculated as below:

$$\Delta I_{PP} = \frac{(V_{OUT} - V_{SD_BAT}) * V_{SD_BAT}}{V_{OUT} * F_{SW}} * \frac{1}{L}$$



$$I_{L_PK} = I_{OUT} + \frac{\Delta I_{PP}}{2}$$

Boost switching module efficiency is dependent on the resistance of its current path, the switching losses associated with the switch MOSFET and the inductor's loss. The inductor's loss is affected a lot by the inductor's DC Resistance (DCR), Equivalent Series Resistance (ESR) at the switching frequency and the core loss. Core loss is related to the core material and different inductors have different core

loss. For a certain inductor, larger current ripple generates higher DCR/ESR conduction losses as well as higher core loss. Normally a datasheet of an inductor does not provide the ESR and core loss information. If needed, consult the inductor vendor for detailed information. Generally, an inductor with lower DCR/ESR is recommended for the LP7800S device application.

Preliminary Datasheet



Packaging Information

ESOP-8

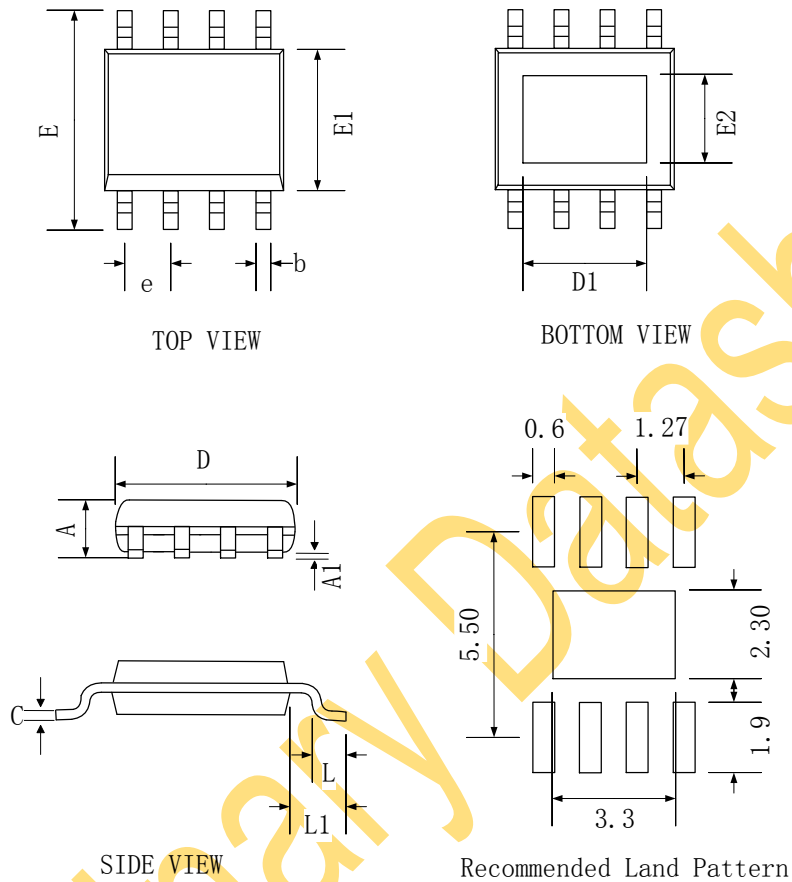

SYMBOL	Dimensions In Millimeters		
	MIN	NOM	MAX
A	1.35	-	1.75
A1	0.00	-	0.15
b	0.30	0.40	0.50
c	0.20 REF		
D	4.70	4.90	5.10
D1	3.2 REF		
E	5.70	6.00	6.30
E1	3.70	3.90	4.10
E2	2.30 REF		
e	1.27 BSC		
L	0.40	0.60	0.80
L1	1.05 REF		