

600mA LNB Power Supply & Control Voltage Regulator

General Description

Designed for analog and digital satellite receivers/sat-TV, the LP6220A is a adjustable voltage regulator, specifically to provide the 14V/19V power supply and the 22kHz tone signaling to the LNB converter in the antenna dish or to the multi-switch box.

LP6220A consists of a BOOST converter with a internal power MOS running at 1MHz switching frequency and a LDO regulator which with push-pull output stage generates clean 22-kHz tone signal superimposed at the output even at zero loading. The EXTM can accept a DiSEqC command and transfer it symmetrically to the output to meet DiSEqC 1.x protocol.

Other features include over temperature protection and under-voltage lockout (UVLO). The LP6220A is available in a space saving ESOP-8 package.

Order Information



Features

- ◆ Low noise output to avoid sensitivity of Can Tuner and DISH's LNA dropping down
- ◆ Single chip solution on 700mVpp 22KHz EXTM with 10μ s Trise/Tfall for less Transferring noise
- ◆ LNB Voltages (14V/19V) compatible with common standards, Push-pull output stage minimizes 14→19V and 19V→14V output transition times
- ◆ External 22KHz EXTM input
- ◆ 1MHz Switch Frequency Boost
- ◆ Integrate Low Noise Linear Regulator
- ◆ Under Voltage Lockout
- ◆ Output Short-Circuit Protection
- ◆ Output Over-Current Protection
- ◆ Over-Temperature Protection
- ◆ Available in ESOP-8
- ◆ RoHS Compliant and Halogen Free

Applications

- ◆ LNB Power supply For DVB-S/S2/ABS
- ◆ Digital Set-Top-Box
- ◆ Satellite TV cards
- ◆ STB Satellite Receiver
- ◆ PC Card Satellite

Marking Information

| Device | Marking | Package | Shipping |
|--|-------------------------|---------|----------|
| LP6220ASPF | LPS LP6220A YWXXX | ESOP-8 | 4K/REEL |
| Y: Y is year code. W: W is week code. X: X is series number. | | | |

Typical Application Circuit

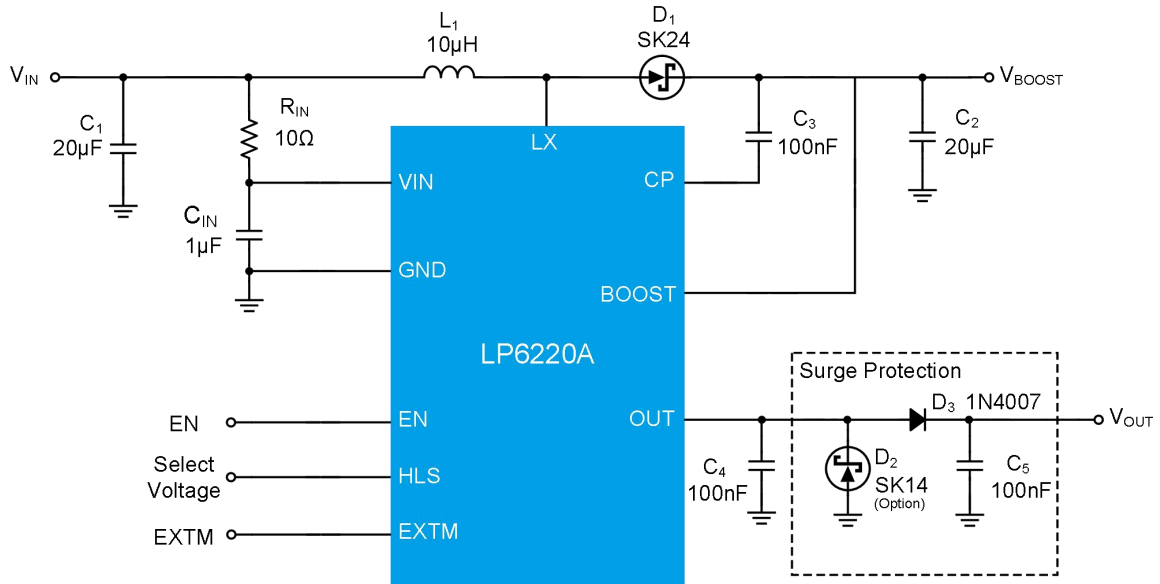

Figure 1. Typical Application Circuit of LP6220A .

Pin Configuration

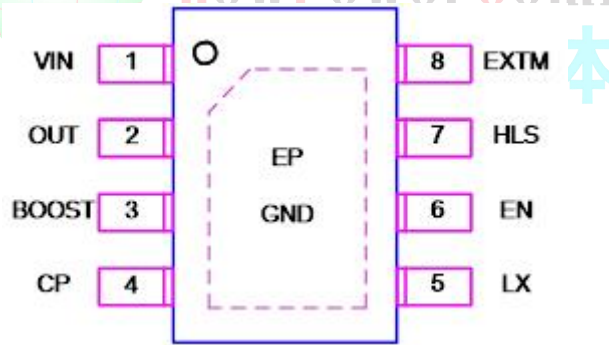

Figure 2. Package Top View

Function Block Diagram

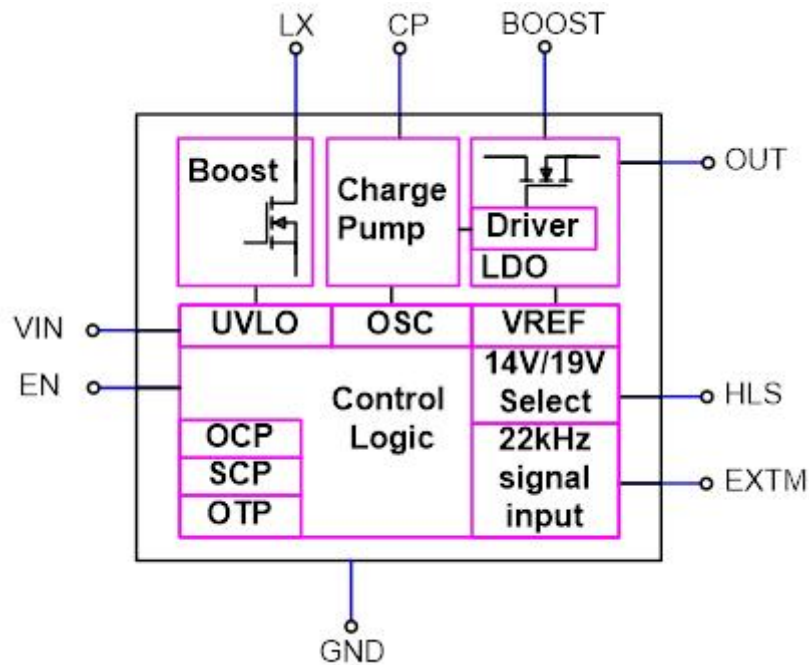

Figure 3. Function Block Diagram

Functional Pin Description

| Pin NO. | ESOP8 | Description |
|---------|-------|--|
| 1 | VIN | Power Source Input. Connect a ceramic capacitor between VIN and GND. |
| 2 | OUT | Output Voltage for LNB. |
| 3 | BOOST | Boost converter output Voltage sense and internal LDO's input terminal. |
| 4 | CP | Charge Pump for LDO use. |
| 5 | LX | Boost Regulator Switching Node. Connect the inductor and the schottky diode to LX. |
| 6 | EN | Enable Pin. |
| 7 | HLS | LNB output Voltage Set Pin. HLS=H:19V; HLS=L:14V |
| 8 | EXTM | 22KHz external modulation signal input Pin. |
| EP | GND | Ground. |

Absolute Maximum Ratings ^{Note1}

| | | |
|--|-------|-----------------|
| ◇ VIN to GND | ----- | -0.3V to +27V |
| ◇ BOOST, OUT to GND | ----- | -0.3V to +22.5V |
| ◇ LX to GND(10ns) | ----- | -0.3V to +36V |
| ◇ CP to GND | ----- | -0.3V to +27V |
| ◇ EN, HLS, EXTM to GND | ----- | -0.3V to +6V |
| ◇ Operating Junction Temperature Range (T _J) | ----- | -40°C to +125°C |
| ◇ Operation Ambient Temperature Range | ----- | -40°C to +85°C |
| ◇ Storage Temperature Range | ----- | -65°C to +150°C |
| ◇ Maximum Soldering Temperature (at leads, 10sec) | ----- | +260°C |

Note1. Stresses beyond those listed under “Absolute Maximum Ratings” may cause permanent damage to the device. These are stress ratings only, and functional operation of the device at these or any other conditions beyond those indicated in the operational sections of the specifications is not implied. Exposure to absolute maximum rating conditions for extended periods may affect device reliability.



Electrical Characteristics

($V_{IN} = 12V$, $T_A = 25^{\circ}C$ (Unless Otherwise Specified))

| Parameter | Symbol | Test Conditions | Min | Typ | Max | Units |
|---|-------------------|--|-----|-----|------|-------------|
| Supply and Reference Function | | | | | | |
| Power Source Voltage | V_{IN} | | 9 | 12 | 14 | V |
| Power Source Current | I_Q | EN=H,HLS=L,EXTM=0V, $V_{OUT}=16V$ | | 2 | 3.5 | mA |
| | | EN=H,HLS=H | | 24 | | mA |
| Shutdown Current | I_{SD} | EN=L | | 0.3 | 1.2 | mA |
| Input Under Voltage Lockout Threshold | V_{UVLO} | V_{IN} Rising | 7.4 | 8 | 8.4 | V |
| UVLO Threshold Hysteresis | ΔV_{UVLO} | Falling Hysteresis | | 0.3 | | V |
| Thermal Shutdown Threshold ⁽²⁾ | T_{SD} | | | 160 | | $^{\circ}C$ |
| Thermal Shutdown Threshold Hysteresis ⁽²⁾ | ΔT_{SD} | | | 25 | | $^{\circ}C$ |
| EXTM | | | | | | |
| EXTM Threshold Voltage | V_{IH} | | 1.4 | | | V |
| | V_{IL} | | | | 0.4 | V |
| EXTM Internal Pull-Low Current | I_{EXTM} | Sink | | 4 | | μA |
| Input EXTM Frequency Range ⁽²⁾ | F_{EXTM} | | 20 | 22 | | kHz |
| VO _{UT} Output EXTM Amplitude ⁽²⁾ | $V_{pp(EXTM)}$ | $I_{LOAD}=0\sim 0.5A$, $C_{LOAD}=100nF$ | | 700 | | mV |
| VO _{UT} Output EXTM Duty ⁽²⁾ | D_{EXTM} | | | 50 | | % |
| VO _{UT} EXTM Rising Time ⁽²⁾ | T_{R_EXTM} | $I_{LOAD}=0\sim 0.5A$, $C_{LOAD}=100nF$ | 7.5 | 10 | 12.5 | μs |
| VO _{UT} EXTM Falling Time ⁽²⁾ | T_{F_EXTM} | $I_{LOAD}=0\sim 0.5A$, $C_{LOAD}=100nF$ | 7.5 | 10 | 12.5 | μs |
| Logic (EN, HLS) | | | | | | |
| EN Threshold Voltage | V_{ENH} | | 1.4 | | | V |
| | V_{ENL} | | | | 0.4 | V |
| EN Internal Pull-High Current | I_{EN} | Source | | 12 | | μA |
| HLS Threshold Voltage | V_{HLH} | | 1.4 | | | V |
| | V_{HLL} | | | | 0.4 | V |
| HLS Internal Pull-Low Current | I_{HL} | Sink | | 4 | | μA |

Note 2. The parameter is guaranteed by design and characterization.

Electrical Characteristics(Continued)

($V_{IN} = 12V$, $T_A = 25^{\circ}C$ (Unless Otherwise Specified))

| Parameter | Symbol | Test Conditions | Min | Typ | Max | Units |
|--|---|--|------|------|------|-------|
| Boost Regulator | | | | | | |
| Internal Oscillator Frequency | F_{OSC} | | 0.8 | 1 | 1.2 | MHz |
| Switch On Resistance ⁽²⁾ | $R_{DS(ON)}$ | | | 150 | | mΩ |
| Maximum Duty Cycle ⁽²⁾ | D_{MAX} | | | 80 | | % |
| Minimum On Time ⁽²⁾ | $T_{ON(MIN)}$ | | | 90 | | ns |
| Current Limit ⁽²⁾ | I_{LIMIT} | | | 2.2 | | A |
| Output Voltage | | | | | | |
| Output voltage | V_{OUT} | EN=H, HLS=H | 18.5 | 19 | 19.5 | V |
| | | EN=H, HLS=L | 13.6 | 14 | 14.4 | V |
| Linear regulator drop voltage ⁽²⁾ | V_{DROP} | EN=H, ILOAD=500mA. | | 0.7 | | V |
| VOUT Line Regulation ⁽²⁾ | $\frac{\Delta V_{OUT}}{(V_{OUT} \times \Delta V_{IN})}$ | $V_{IN}=9\sim 14V$, $V_{OUT}=19V$ | | 0.05 | 0.2 | %/V |
| VOUT Output Load Regulation ⁽²⁾ | $\frac{\Delta V_{OUT}}{V_{OUT}}$ | $I_{LOAD}=0\sim 500mA$, $V_{OUT}=19V$ $C_{OUT}=0.1\mu F$ | | 0.5 | | % |
| Output Current limit ⁽²⁾ | I_{LIMIT} | | | 650 | | mA |

Note 2. The parameter is guaranteed by design and characterization.

Application Information

The LP6220A is a power management IC that integrates a boost converter, a LDO, and a 22-kHz tone transfer that serves as a LNB power supply. OUT voltage set by HLS pin, and accepts a tone modulated DiSEqC command and transfers it symmetrically to the output to meet DiSEqC 1.x protocol.

Under Voltage Lockout (UVLO)

The LP6220A had an UVLO internal circuit that enable the device once the voltage on the V_{IN} voltage exceeds the UVLO threshold voltage.

Boost Converter

The LP6220A use 1MHz fixed-frequency, current mode architecture to regulate the output voltage. The LP6220A measures the output voltage through BOOST pin, and use the internal compensation to saving external element.

Linear Regulator

The linear regulator features low drop out voltage to minimize power loss while keeping enough head room for the 22-kHz tone. It also implements a tight current limit for over current protection. The linear regulator is used to generate the 22-kHz tone signal by changing the reference voltage.

Over Load Protection

When the LNB OUT current over the preset over current threshold and the status continues for 65ms, the device enters a auto-retry routine. The device returns to normal operation after the status release.

EXTM input

Once LP6220A is enable, it can applying 22kHz, 50% square pulse on EXTM in generates the DISEQ EXTM ($\pm 350mV$) on the output VOUT.

DiSEqC Encoding

The EXTM accepts an externally modulated EXTM. command and in turn modulates the VOUT symmetrically to meet the DiSEqC 1.x and with few more external components to meet DiSEqC 2.0 transmit protocol. Burst coding of the EXTM can be accomplished due to the fast response of the EXTM pin.

Over Temperature Protection

The LP6220A device enters over temperature protection if its junction temperature exceeds $160^{\circ}C$ (typical). During over temperature protection none of the device's functions are available. To resume normal operation the junction temperature need cool down, and the outputs will restart.

Layout Consideration

The proper PCB layout and component placement are critical for all circuit. Here are some suggestions to the layout of LP6220A design.

1. The input capacitor should be located as closed as possible to the V_{IN} and ground plane.
2. Minimize the distance of all traces connected to the LX node, that the traces short and wide route to obtain optimum efficiency.
3. All output capacitor must be closed to ground plane. The ground terminal of COUT must be located as closed as possible to ground plane.
4. Radiated noise can be decreased by choosing a shielded inductor.

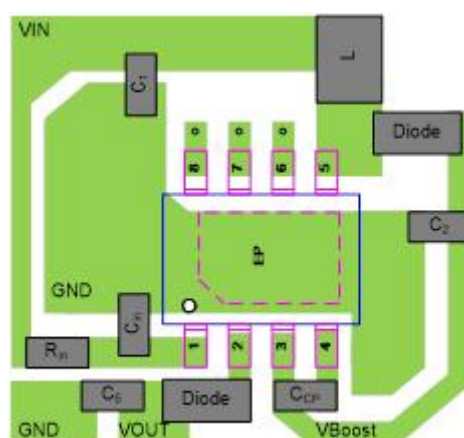
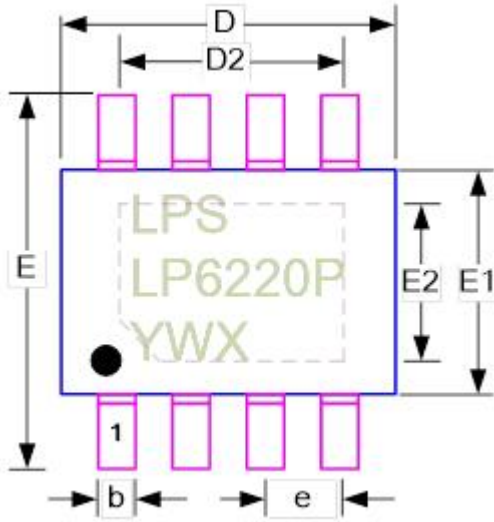

Figure 4. Recommended PCB Layout Diagram



Outline Information

ESOP-8 Package (Unit: mm)



| SYMBOLS UNIT | DIMENSION IN MILLIMETER | |
|-----------------|-------------------------|-------|
| | MIN | MAX |
| A | 1.300 | 1.700 |
| A1 | 0.000 | 0.100 |
| A2 | 1.250 | 1.520 |
| b | 0.330 | 0.510 |
| D | 4.800 | 5.000 |
| D2 | 3.150 | 3.450 |
| E | 5.800 | 6.200 |
| E1 | 3.800 | 4.000 |
| E2 | 2.260 | 2.560 |
| e | 1.270 BSC | |
| L | 0.410 | 1.270 |

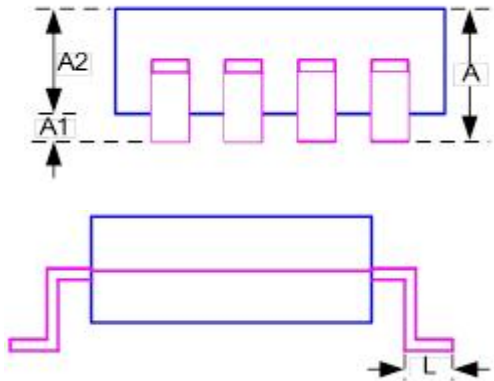

LowPowerSemi
微源半导体