



Features

- Easy-to-use standalone single-cell charger
- High input voltage linear charger
 - Support up to 7V operating input voltage with 28V absolute maximum input rating
 - Maximum BAT withstand voltage up to 15V
 - Programmable up to 1A fast charge current
 - $\pm 1\%$ regulated output voltage accuracy
 - Trickle current 20% of fast charge current
 - Termination current 10% of fast charge current
- High integration
 - Integrated reverse blocking MOSFET
 - Built-in charge current sensing
 - Internal loop compensation
 - Integrated charge status indication
- Support full charge cycle of trickle current mode, constant current (CC) mode, constant voltage (CV) mode, charge termination and automatic recharge
- BAT leakage current $< 1\mu\text{A}$
- Protection features
 - Input under-voltage lockout (UVLO)
 - Input over-voltage protection (OVP)
 - Battery reverse connection protection
 - Thermal regulation
- RoHS Compliant and 100% Lead (Pb)-Free
- Package: DFN-10(3mm x 3mm)

Applications

- Wireless Speaker
- Cordless Power Tools
- Gaming Devices
- Portable Media Players
- Handheld Battery-Powered Devices
- Charging Docks and Cradles
- Power Bank
- E-Cigarettes

Order Information

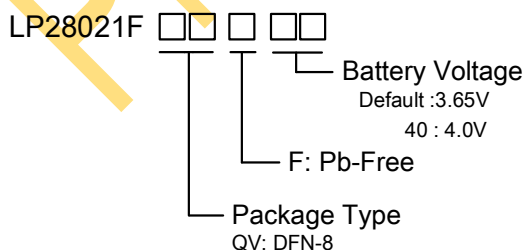

General Description

The LP28021F is a highly advanced linear charger for single cell LiFePO4 and Li-Ion batteries. The device is ideally suited for portable applications due to low number of external components required.

The device employs a full charge algorithm with trickle current, constant current (CC), constant voltage (CV) modes, charge termination and automatic recharge. The device supports charge current up to 1A, programmed by an external resistor. The device can withstand an input voltage up to 28V, which can protect the charger from the accidental insertion of a high voltage supply or a hot insertion. The device can withstand a BAT voltage up to 15V, which is suited for power battery applications. Without an input supply, the battery leakage current is less than $1\mu\text{A}$.

The device provides various safety features for battery charging, including input under voltage lockout (UVLO), input over-voltage protection (OVP), battery reverse connection protection, and thermal regulation protection that is implemented by reducing the charge current when the junction temperature reaches 145°C .

The LP28021F is available in a DFN-10 (3mmx3mm) package.

Typical Application Circuit

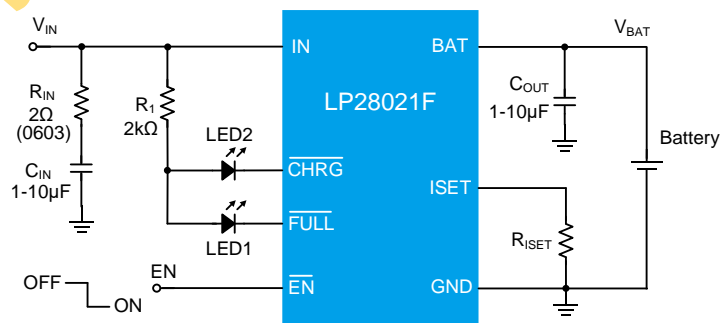



Device Information

Part Number	Top Marking	Battery Voltage	Moisture Sensitivity Level	Package	Shipping
LP28021FQVF	LPS LP28021F YWX	3.65V	MSL3	DFN-10	4K/REEL
LP28021FQVF-40	LPS LP28021F 40YWX	4.00V	MSL3	DFN-10	4K/REEL
Marking indication: Y: Production year. W: Production week. X: Series number.					

Preliminary Datasheet



Pin Diagram

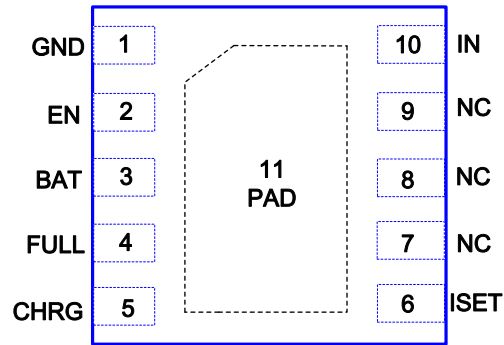

DFN-10 (Top View)

Pin Description

Pin	Name	Description
1	GND	GND. Connect to the system ground.
2	EN	Charge Enable Input. Low active.
3	BAT	Battery Pin. Connect to the battery, A 1-10 μ F capacitor is needed typically.
4	FULL	Open-Drain Status Output. When the device is in charging state, the FULL pin is pulled high by an external pull-up resistor. When the charge cycle is completed, the pin is pulled down by an internal NMOS.
5	CHRG	Open-Drain Charge Status Output. When the device is in charging state, the CHRG pin is pulled down by an internal NMOS. When the charge cycle is completed, the internal NMOS turned-off, the pin could be pulled high by an external pull-up resistor.
6	ISET	Fast Charge Current Program Pin. Connect this pin with an external resistor R_{ISET} to GND to program the fast charge current.
7/8/9	NC	No Connection.
10	IN	Positive Supply Voltage Input. Place a 2 Ω resistor and a 1-10 μ F ceramic capacitor in series from IN to GND, and place the components as close as possible to IC.
11	PAD	Ground reference for the device that is also the thermal pad used to conduct heat from the device.



Absolute Maximum Ratings ⁽¹⁾

IN to GND	-----	-0.3V to 28V
CHRG, FULL to GND	-----	-0.3V to 28V
BAT to GND	-----	-5V to 15V
EN, ISET to GND	-----	-0.3V to 6.5V
Maximum Junction Temperature (T _J)	-----	150°C
Storage Temperature	-----	-55°C to 150°C
Maximum Soldering Temperature (at leads, 10 sec)	-----	260°C

Note: (1) Stresses beyond those listed under “Absolute Maximum Ratings” may cause permanent damage to the device. These are stress ratings only, and functional operation of the device at these or any other conditions beyond those indicated in the operational sections of the specifications is not implied. Exposure to absolute maximum rating conditions for extended periods may affect device reliability.

ESD Susceptibility

HBM (Human Body Model)	-----	2kV
MM (Machine Model)	-----	200V

Recommended Operating Conditions

Input Voltage	-----	4.5V to 6V
Maximum Charge Current	-----	1A
Operating Junction Temperature Range (T _J)	-----	-20°C to 145°C
Operating Ambient Temperature Range (T _A)	-----	-20°C to 85°C

Preliminary Datasheet



Electrical Characteristics

(The specifications are at $T_A=25^{\circ}\text{C}$, $V_{IN} = 5\text{V}$, unless otherwise noted.)

SYMBOL	PARAMETER	CONDITION	MIN	TYP	MAX	UNITS
INPUT VOLTAGE AND CURRENT						
V_{IN}	Input Voltage Range		4.5	5	6.5	V
I_{IN_STB}	Input Standby Current	Standby mode Charge terminated, $V_{EN}=0\text{V}$		160		μA
I_{IN_SD}	Input Shutdown Current	$V_{EN}=5\text{V}$		60		μA
V_{UVLO}	Under Voltage Lockout of V_{IN}	V_{IN} Rising	3.3	3.5	3.7	V
V_{UVLO_HYS}	V_{UVLO} Hysteresis	V_{IN} Falling		150		mV
V_{OVP}	Over-Voltage Protection Threshold Voltage	V_{IN} Rising	6.7	7	7.3	V
V_{OVP_HYS}	OVP Hysteresis	V_{IN} Falling		300		mV
BAT LEAKAGE CURRENT						
$I_{BAT_Leakage}$	Battery Leakage Current	LP28021FQVF V_{IN} floating, $V_{BAT}=3.65\text{V}$			-1	μA
BATTERY CHARGER						
V_{FLOAT}	Regulated Output Voltage	LP28021FQVF	3.613	3.65	3.686	V
		LP28021FQVF-40	3.96	4.0	4.04	
I_{CC}	Fast Charge Current	$R_{ISET}=3.4\text{k}\Omega$, Constant Current Mode	460	500	540	mA
		$R_{ISET}=17\text{k}\Omega$, Constant Current Mode	90	100	110	mA
I_{TERM}	Termination Current Threshold	$R_{ISET}=3.4\text{k}\Omega$, Constant Voltage Mode		10%		I_{CC}
I_{TRIKL}	Trickle Charge Current	$V_{BAT}<V_{TRIKL}$, $R_{ISET}=3.4\text{k}\Omega$		20%		I_{CC}
V_{TRIKL}	Trickle Charge Threshold Voltage	LP28021FQVF V_{BAT} Rising	2.25	2.4	2.55	V
V_{TR_HYS}	Trickle Charge Hysteresis Voltage	LP28021FQVF V_{BAT} Falling		120		mV
ΔV_{RECHRG}	Battery Recharge Voltage Difference Threshold ($V_{FLOAT} - V_{RECHRG}$)	LP28021FQVF V_{BAT} Falling	100	150	200	mV
$V_{DF_Lockout}$	IN-BAT Difference Lockout Threshold Voltage	$V_{BAT}=3.2\text{V}$, V_{IN} Rising	110	130	150	mV
$V_{DF_Lockout_HYS}$	IN-BAT Difference Lockout Voltage Hysteresis	$V_{BAT}=3.2\text{V}$, V_{IN} Falling		60		mV
T_{J_LIMIT}	Junction Temperature Limit	Thermal Foldback Protection State		145		$^{\circ}\text{C}$
R_{DS}	IN-BAT ON-resistance	Charge Current=500mA		950		m Ω



Electrical Characteristics (Continued)

(The specifications are at $T_A=25^{\circ}\text{C}$, $V_{IN} = 5\text{V}$, unless otherwise noted.)

ISET/CHRG/FULL PINS						
V_{ISET_CC}	ISET Pin Voltage	Constant Current Mode	0.9	1	1.1	V
V_{ISET_TR}		Trickle Current Mode		0.1		V
V_{STAT_LOW}	STAT Pin Output Low Voltage	$I_{STAT_SINK}=5\text{mA}$			0.5	V
I_{STAT_SINK}	CHRG/FULL Pin Sink Current	STAT pin pulled down			-5	mA
I_{STAT_Leakge}	CHRG/FULL Pin Leakage Current	STAT pin high impedance			-1	μA
EN FUNCTION						
V_{EN_ON}	EN Logic-Low Voltage Threshold	EN Falling			0.4	V
V_{EN_OFF}	EN Logic-High Voltage Threshold	EN Rising	1.4			V
$I_{EN_Leakage}$	EN pin leakage current	$V_{EN}=5\text{V}$ or $V_{EN}=0\text{V}$	-1		1	μA

Preliminary Datasheet



Typical Characteristics

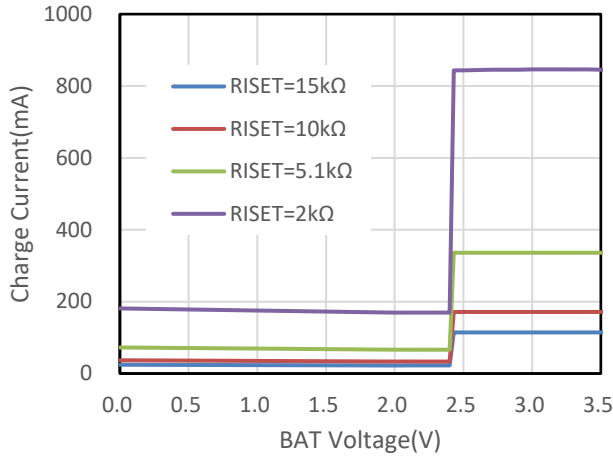

Figure 1. Charge Current vs BAT Voltage
 $V_{IN}=5V, 25^{\circ}C$

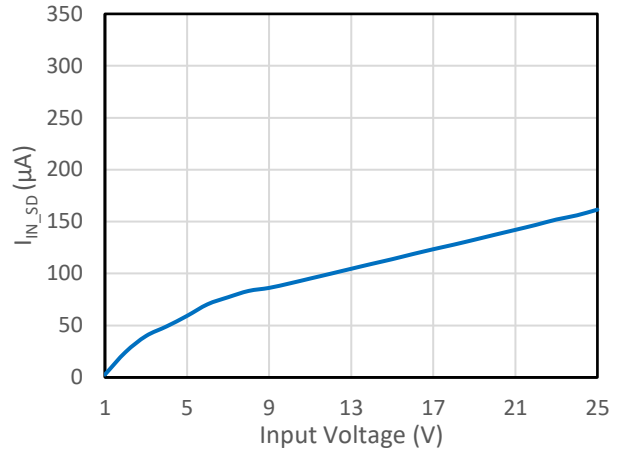

Figure 2. Input Shutdown current vs Input Voltage
Charge terminated, $25^{\circ}C$

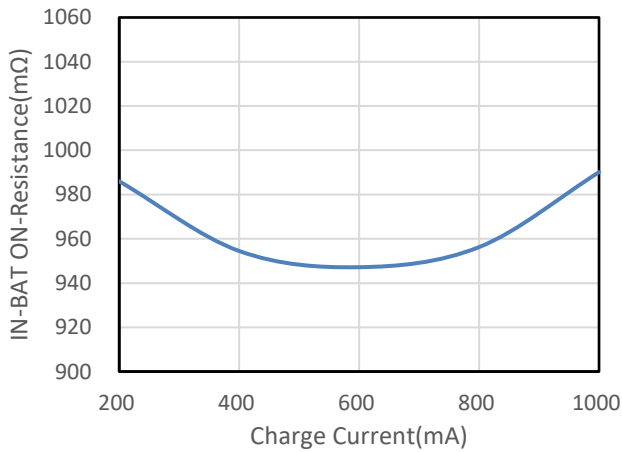

Figure 3. IN-BAT ON-Resistance vs Charge Current
 $V_{BAT}=3.2V, 25^{\circ}C$

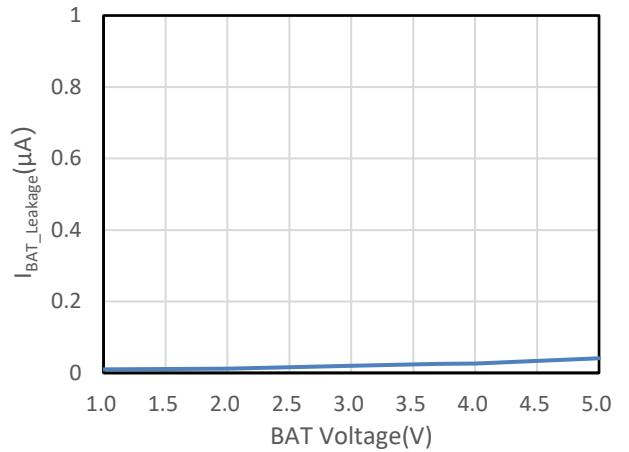

Figure 4. BAT Leakage Current vs V_{BAT}
 $V_{IN}=Floating, 25^{\circ}C$

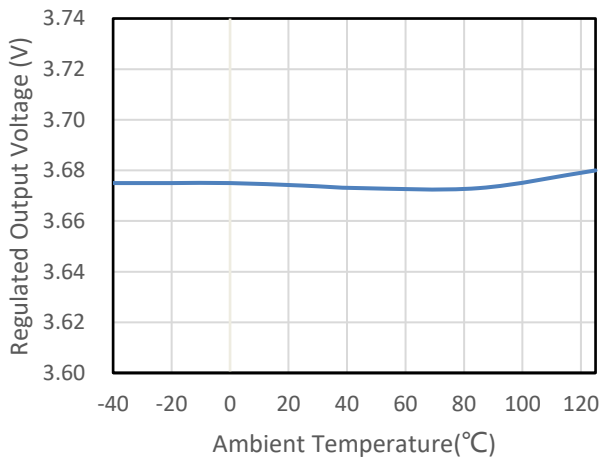
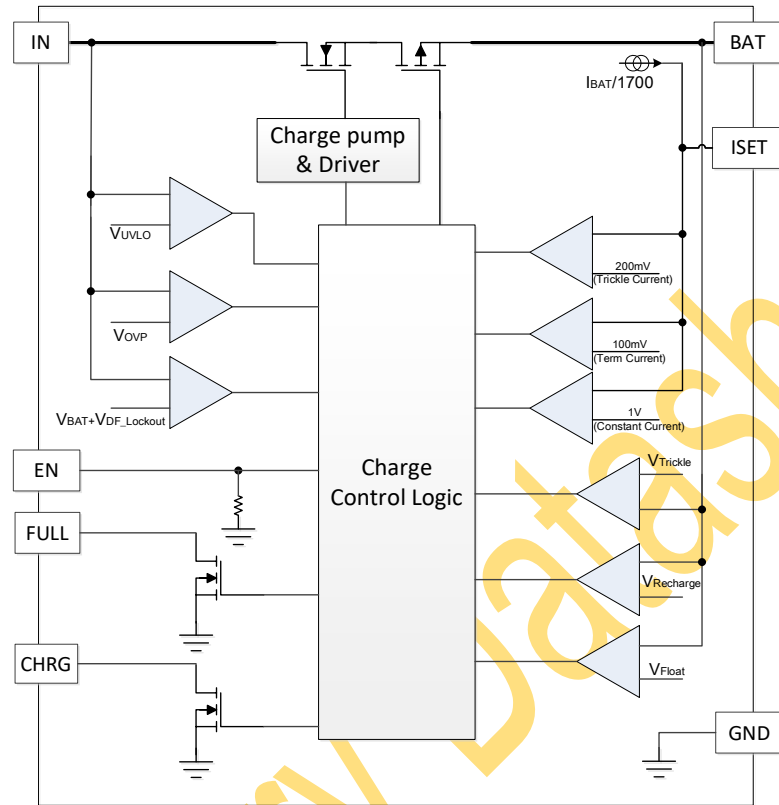

Figure 5. Regulated Output Voltage (V_{FLOAT}) vs Ambient Temperature



Functional Block Diagram



Preliminary Data Sheet



Detailed Description

Overview

The LP28021F is a highly advanced linear charger with up to 1A maximum charge current for single cell LiFePO4 and Li-Ion batteries. The device charges the battery with full charge cycle: trickle current mode, constant current mode (CC), constant voltage mode (CV), charge termination and recharge. The typical charge profile can be showed as the figure below.

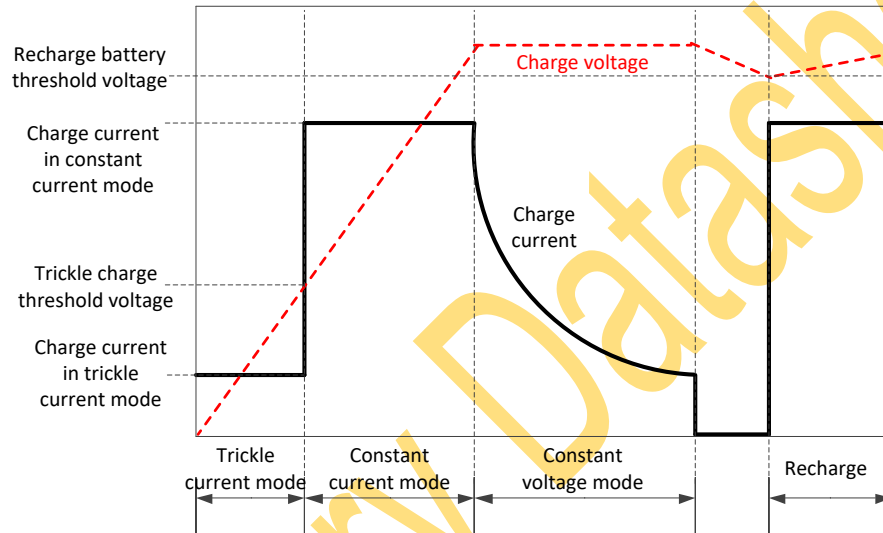

When the battery voltage is lower than Trickle Charge Threshold Voltage (V_{TRIKL} , 2.4V typical), the device charges in the trickle current mode, the charge current will be set to Trickle Charge Current (I_{TRIKL}), which is approximately 20% of the ISET programmed Fast Charge Current (I_{CC}) to bring the battery voltage up to a safe level for full current charging. When the battery voltage rises to V_{TRIKL} , the device enters the constant current mode, where the charge current is 100% I_{CC} . When the battery voltage approaches the Regulated Output Voltage (V_{FLOAT}), the device goes to constant voltage mode, the charge current starts to decrease. When the charge current is lower than the Termination Current threshold (I_{TERM}), which is 10% I_{CC} , the device will terminate the charging.

Once the charge cycle is terminated, the LP28021F continuously monitors the voltage on the BAT pin by a comparator. A new charge cycle starts when the battery voltage drops by a voltage difference ΔV_{RECHRG} (150mV, typical) from V_{FLOAT} , which means the battery level drops to approximately 80% to 90% capacity. This ensures that the battery always keeps at or near a fully charged condition.

ISET Programming Fast Charge Current

The Fast Charge Current (I_{CC}) is set by a resistor (R_{ISET}) connecting from the ISET pin to GND. The relationship between I_{CC} and the programming resistance is established by the following formula:

$$I_{CC} = \frac{V_{ISET} \times 1700}{R_{ISET}}$$

where V_{ISET} =1V typical.



Undervoltage Lockout (UVLO) and IN-BAT Difference Lockout

An internal UVLO circuit monitors the input voltage and keeps the device in Shutdown mode until the input supply rises above the UVLO threshold. The UVLO circuitry has a built-in hysteresis of 150 mV. The UVLO circuit always be active.

In addition, the input supply must be $V_{DF_Lockout}$ (130mV, typical) higher than the battery voltage before the LP28021F become operational. Whenever the input supply is below the UVLO threshold or lower than a voltage of $V_{DF_Lockout}$ above the VBAT pin, the LP28021F is in Shutdown mode.

Enable Function

The LP28021F features an enable/disable function. An input “Low” signal or floating connection on EN pin will enable the device. To ensure the device to be active, the EN low voltage level must be lower than 0.4V. The device will enter the shutdown mode when the voltage on the EN pin is higher than 1.4V. If the enable function is not needed in a specific application, the EN pin can be shorted to GND or left floating to keep the device continuously active.

Charge Status Indicator (CHRG & FULL)

When the input voltage is above the V_{UVLO} and above the voltage of $V_{BAT} + V_{DF_Lockout}$, but lower than V_{OVP} , CHRG pin and FULL pin have two different states: pull-down state and high impedance state. The pull-down state of CHRG implemented by an internal NMOS indicates that the LP28021F is in a charge cycle. After the charge current decreased to I_{TERM} in CV mode and then charging terminated, the CHRG pin will become high impedance state, the FULL pin will become pull-down state from high impedance state.

Function	CHRG	FULL
Charging	Pull-down	Hi-Z
Charge Terminated	Hi-Z	Pull-down

Thermal Regulation Foldback

An internal thermal regulation foldback loop reduces charge current if the junction temperature reaches a preset value of approximately 145°C to prevent further temperature rise. This function protects the device from excessive temperature and allows the user to get the limits of the power handling capability of a given circuit board without the risk of damaging the device. The charge current can be set according to typical ambient temperature with the assurance that the charger will automatically reduce the current in worst-case conditions.

Charge termination function will not be active when thermal foldback regulation protection is happening.



Application Information

Thermal Consideration

Due to low efficiency of linear charging, the most important factor is thermal design, which is a direct function of input voltage, output charge current and thermal impedance between the battery charger and the ambient cooling air. The power dissipation can be calculated approximately:

$$P_D = (V_{IN} - V_{BAT}) \times I_{BAT}$$

where PD is the power dissipation, V_{IN} is the input supply voltage, V_{BAT} is the battery voltage and I_{BAT} is the charge current.

The worst-case situation is when the device has transitioned from the trickle current mode to the constant current mode. In this situation, the battery charger has to dissipate the maximum power.

In this case, with a 5V input voltage source, 1A fast charge current, the max power dissipation could be:

$$P_{Dmax} = (5V - 2.4V) \times 1A = 2.6W$$

This power dissipation with the battery charger in the DFN-10 package may cause thermal regulation foldback to reduce the charge current. Then a trade-off must be made between the charge current and thermal requirements of the charger.

External Capacitors

In order to maintain good stability in the whole charge cycle, a capacitance of 1-10 μ F is recommended to bypass the BAT pin to GND. In addition, the battery and interconnections appear inductive at high frequencies. These elements are in the control feedback loop during constant voltage mode. Therefore, the bypass capacitance may be necessary to compensate for the inductive nature of the battery pack.

Layout Consideration

For optimum voltage regulation, place the battery pack as close as possible to the device's BAT and GND pins. This is recommended to minimize voltage drops along the high current-carrying PCB traces. If the PCB layout is used as a heat sink, adding many vias in the heat sink pad can help conduct more heat to the PCB backplane, thus reducing the maximum junction temperature. It is also recommended to place the capacitor C_{IN} and C_{OUT} as close as possible to the corresponding pins and the GND pin.



Packaging Information

DFN-10

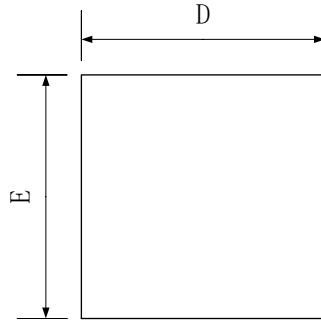

TOP VIEW

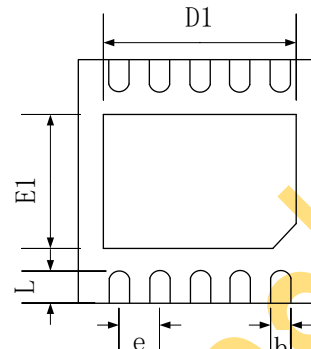

BOTTOM VIEW

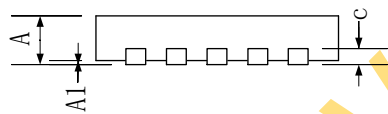

SIDE VIEW

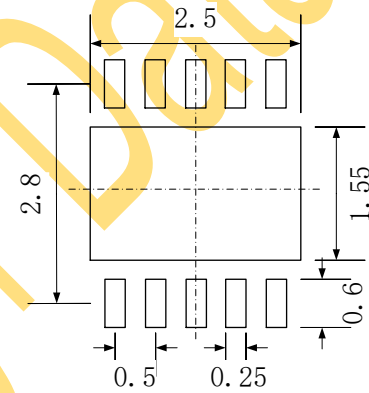

Recommended Land Pattern

SYMBOL	MILLIMETER		
	MIN	NOM	MAX
A	0.70	0.75	0.80
A1	0.00	0.02	0.05
b	0.18	0.25	0.30
C	0.20 REF		
D	2.90	3.00	3.10
D1	2.40	2.50	2.60
E	2.90	3.00	3.10
E1	1.45	1.55	1.65
e	0.50 BSC		
L	0.30	0.40	0.50



Tape and Reel Information

REEL DIMENSIONS

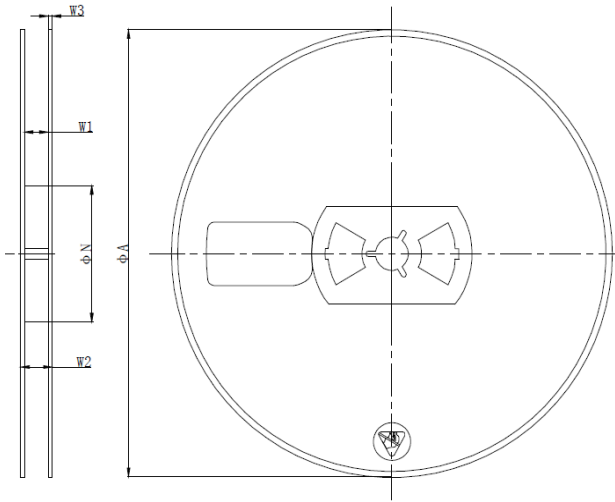

SYMBOL	Dimensions In Millimeters		
	MIN	NOM	MAX
ΦA	327.00	329.00	331.00
W2	14.40	16.40	18.40

TAPE DIMENSIONS

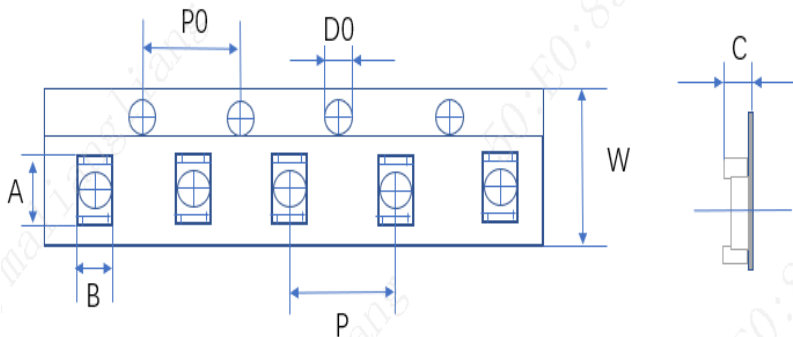

SYMBOL	Dimensions In Millimeters		
	MIN	NOM	MAX
A	3.10	3.40	3.70
B	3.10	3.40	3.70
P0	3.90	4.00	4.10
P	7.90	8.00	8.10
D0	1.45	1.55	1.65
W	11.7	12.00	12.30
C	0.95	1.10	1.25

PIN1 AND TAPE FEEDING DIRECTION

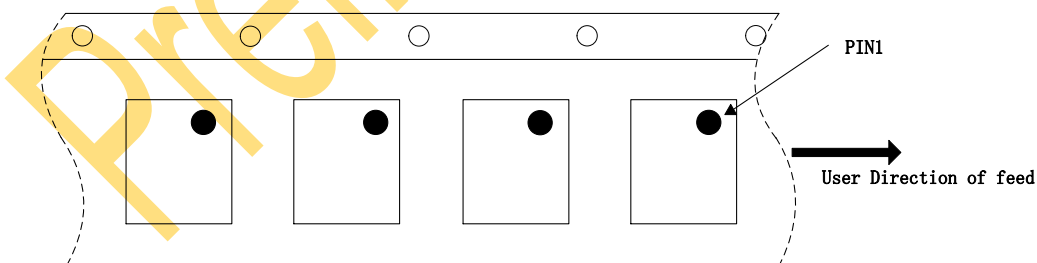



Classification of IR Reflow Profile

Profile Feature	Sn-Pb Eutectic Assembly	Pb-Free Assembly
Preheat/Soak		
Temperature Min(T_{SMIN})	100°C	150°C
Temperature Max(T_{SMAX})	150°C	200°C
Time(T_S) from (T_{SMIN} to T_{SMAX})	60~120 seconds	60~120 seconds
Ramp-up rate (T_L to T_P)	3°C/second max	3°C/second max
Liquidous temperature(T_L)	183°C	217°C
Time(t_L) maintained above T_L	60~150 seconds	60~150 seconds
Peak package body temperature (T_P)	For users T_P must not exceed the Classification temp in Table 1. For suppliers T_P must equal or exceed the Classification temp in Table 1.	For users T_P must not exceed the Classification temp in Table 2. For suppliers T_P must equal or exceed the Classification temp in Table 2.
Time(t_P)* within 5°C of the specified classification temperature(T_C), see Figure1	20* seconds	30* seconds
Ramp-down rate (T_P to T_L)	6°C/second max	6°C/second max
Time 25°C to peak temperature	6 minutes max	8minutes max
* Tolerance for peak profile temperature (T_P) is defined as a supplier minimum and a user maximum.		

Table 1 Sn-Pb Eutectic Process - Classification Temperatures (T_C)

Package Thickness	Volume mm ³ <350	Volume mm ³ ≥350
<2.5mm	235°C	220°C
≥2.5mm	220°C	220°C

Table 2 Pb-Free Process - Classification Temperatures (T_C)

Package Thickness	Volume mm ³ <350	Volume mm ³ 350~2000	Volume mm ³ ≥350
<1.6mm	260°C	260°C	260°C
1.6mm~2.5mm	260°C	250°C	245°C
>2.5mm	250°C	245°C	245°C

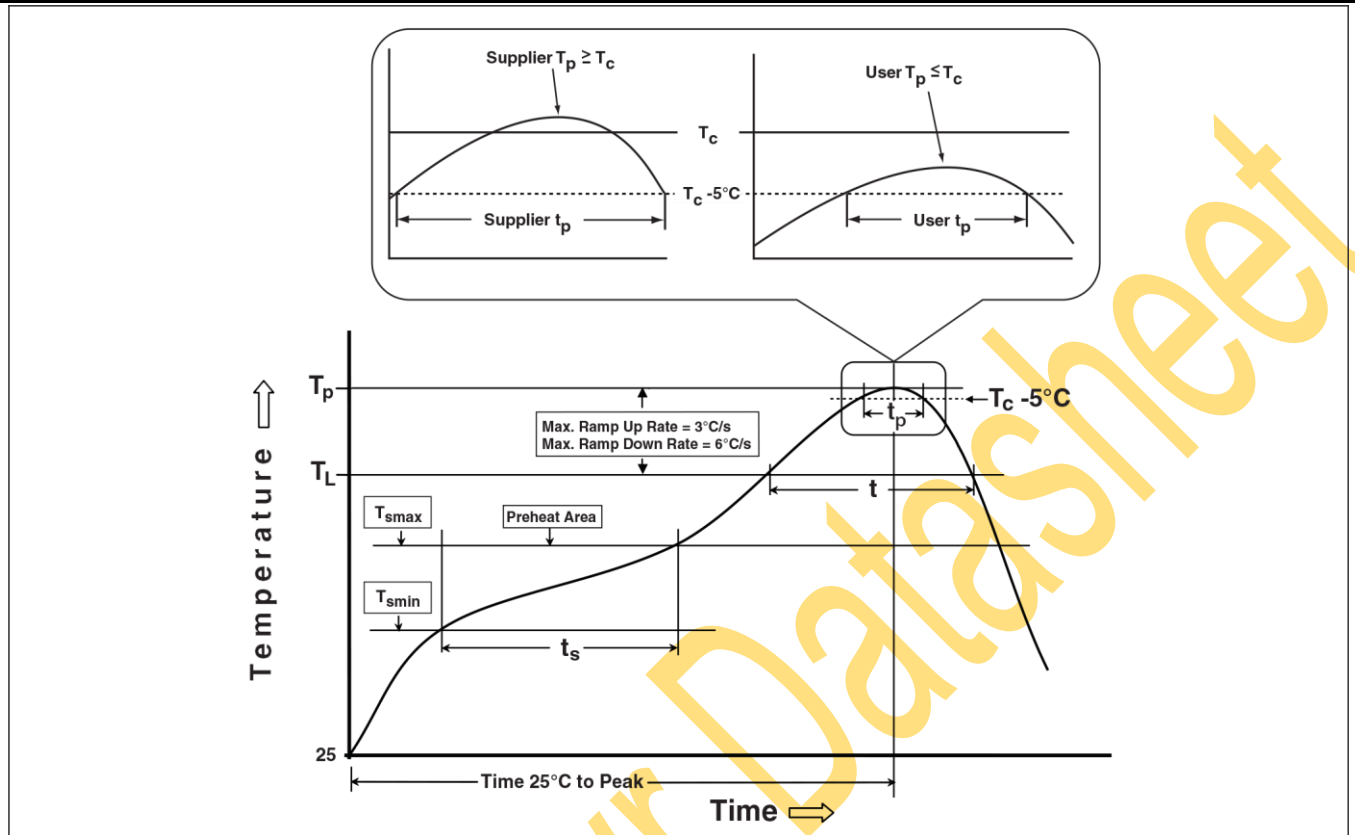

Figure1 Classification Profile (Not to scale)

Products conform to “JEDEC J-STD-020C” standards;

Products shipped conform to “Rohs” standards;

Moisture Sensitivity Level: MSL3 (CONDITION: $\cong 30\text{ }^\circ\text{C}/60\%\text{RH}$ 、Time control:168 hours) ;