

High Performance Regulated Charge Pump

General Description

The LP3110 is a high performance charge pump DC/DC converter that produces a regulated 5V output. No external inductor is required for operation. The operating voltage range is 2.8V to V_{OUT} . Internal soft-start circuitry effectively reduces the in-rush current both while start-up and mode change.

The LP3110 features very low quiescent current, over current protection and short circuit protection.

The LP3110 is available in SOT23-6 package.

Features

- ◆ 2x Mode for Ultra-High Efficiency
- ◆ 2.8V to V_{OUT} Range Input Voltage
- ◆ Soft-Start Function
- ◆ Built-In Short-Circuit Protection
- ◆ 340KHz Fixed frequency
- ◆ Built-in Thermal Protection
- ◆ Over Current Protection Function
- ◆ $I_{SD} < 1\mu A$ in Shutdown
- ◆ SOT23-6 Package
- ◆ RoHS Compliant and 100% Lead (Pb)-Free

Order Information

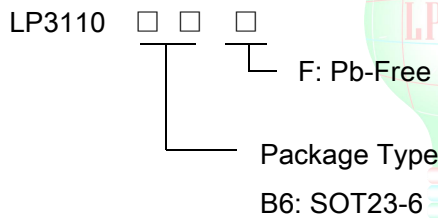

Applications

- ◇ LCD Panel
- ◇ Cellular and Smart mobile phone
- ◇ PDA/DSC
- ◇ Flash LED Driver

Typical Application Circuit

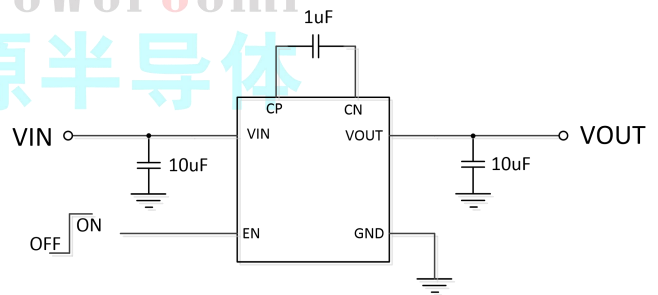

Marking Information

Device	Marking	Package	Shipping
LP3110B6F	LPS D3YW X	SOT23-6	3K/REEL

Marking indication:
Y:Production year W:Production week X:Production batch.

Functional Pin Description

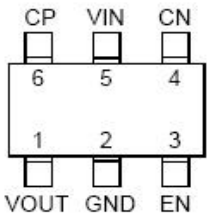
Package Type		Pin Configurations
SOT23-6		(TOP VIEW) 
Pin	Name	Description
1	VOUT	Output Voltage.
2	GND	Ground.
3	EN	Chip Enable (Active High).
4	CN	Flying Capacitor Negative Terminal.
5	VIN	Power Input Voltage.
6	CP	Flying Capacitor Positive Terminal.

Function Block Diagram

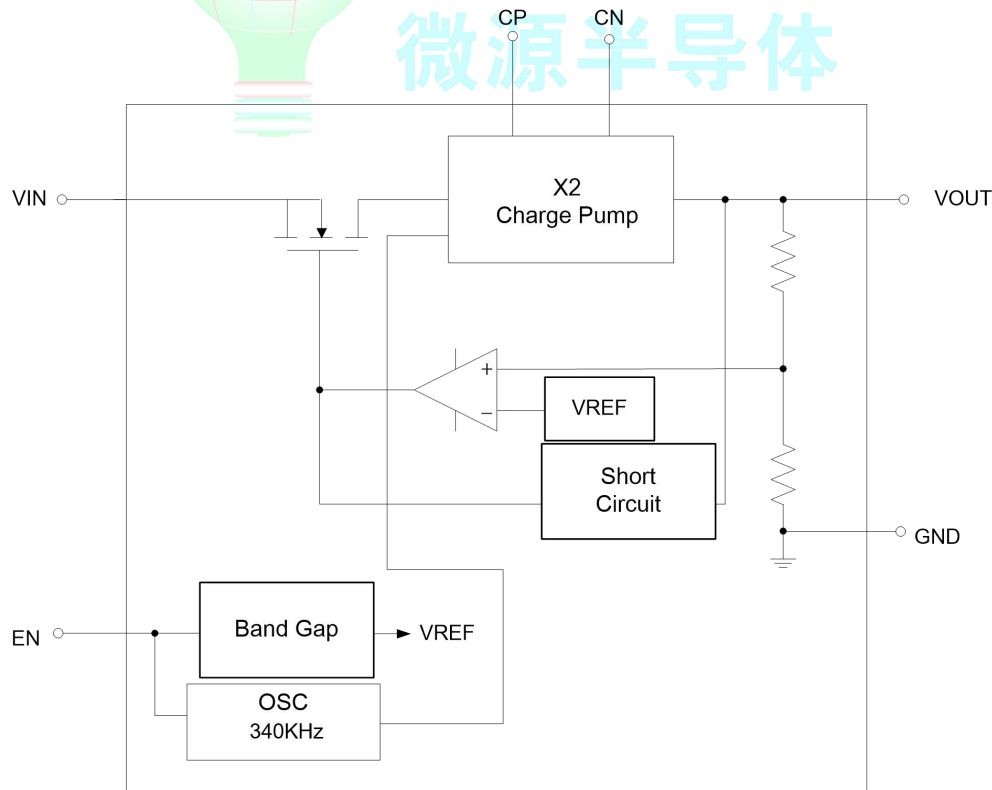

Absolute Maximum Ratings ^{Note 1}

✧	Input Voltage to GND (V_{IN})	-----	6V
✧	EN to GND Voltage (V_{EN})	-----	0.3V to $V_{IN}+0.3V$
✧	Maximum Power Dissipation (P_D)	-----	0.45W
✧	Thermal Resistance (J_A)	-----	250°C/W
✧	Operating Junction Temperature Range	-----	150°C
✧	Maximum Soldering Temperature (at leads, 10sec)	-----	260°C

Note 1. Stresses beyond those listed under “Absolute Maximum Ratings” may cause permanent damage to the device. These are stress ratings only, and functional operation of the device at these or any other conditions beyond those indicated in the operational sections of the specifications is not implied. Exposure to absolute maximum rating conditions for extended periods may affect device reliability.

ESD Susceptibility

✧	HBM(Human Body Mode)	-----	2KV
✧	MM(Machine Mode)	-----	200V

Recommended Operating Conditions

✧	Ambient Temperature Range	-----	-20°C to 85°C
---	---------------------------	-------	---------------

Electrical Characteristics

(Over recommended operating conditions unless specified otherwise, $V_{IN} = 3.6V, EN = High, TA = 25^\circ C$)

Parameter	Symbol	Condition	Min	Typ	Max	Units
Input Voltage	V_{IN}		2.8		V_{OUT}	V
Output Voltage Range	V_{OUT}			5		V
Quiescent Current	I_Q	No Load		2		mA
Shutdown Current	I_{SHDN}	$V_{EN} = GND$			1	μA
Oscillator Frequency	f_{OSC}			340		KHz
Output Short Circuit Current Limit	I_{SC}	$V_{OUT} < 0.5V$	300	350		mA
Enable Threshold Low	$V_{EN(L)}$				0.4	V
Enable Threshold High	$V_{EN(H)}$		1.4			V
Enable Current	I_{EN}	$V_{IN} = V_{EN} = 5.5V$		1		μA



Typical Operating Characteristics

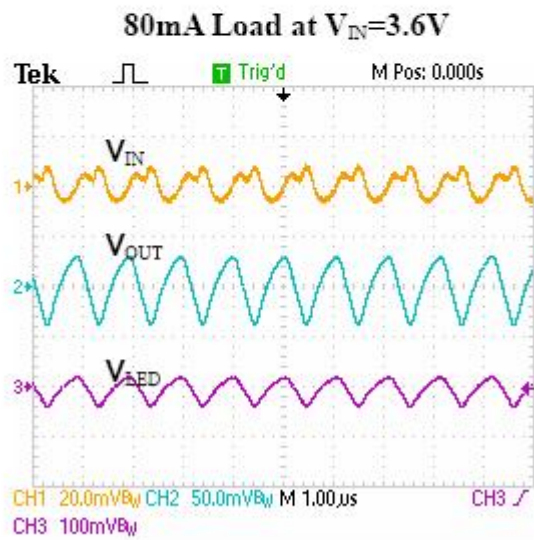
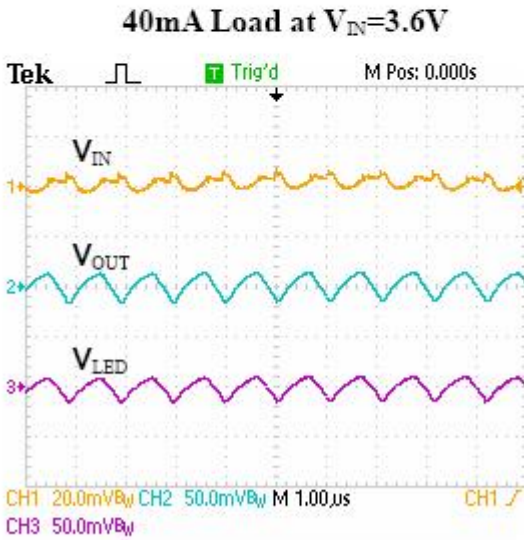
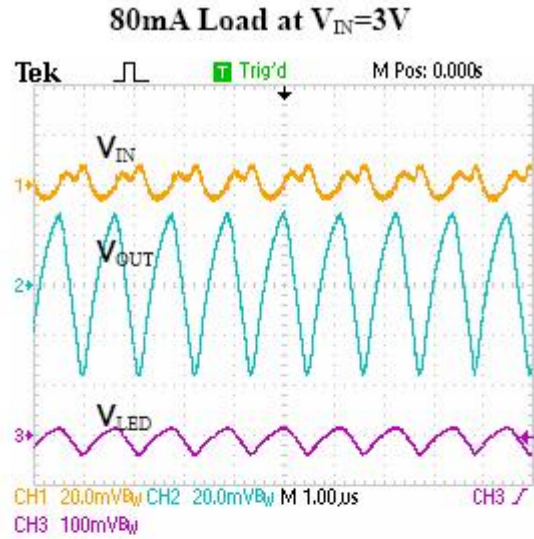
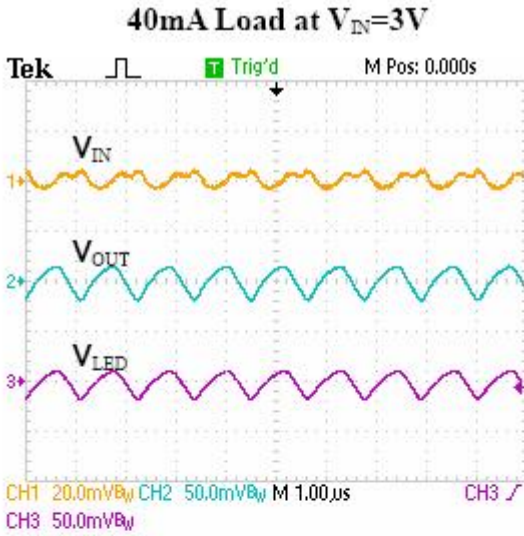

Application Information

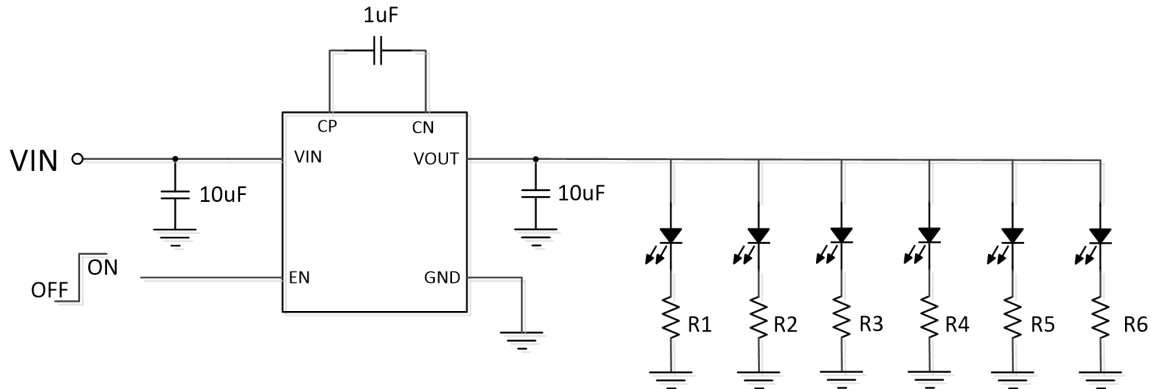

Figure1: Up to 6pcs White/Blue LED Driver from Li-Ion Battery Source

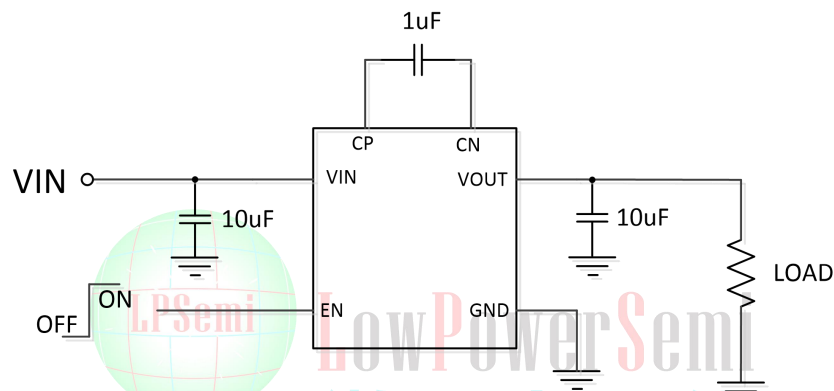

Figure2: Step-up to 5V with loading application from Li-Ion Battery Source

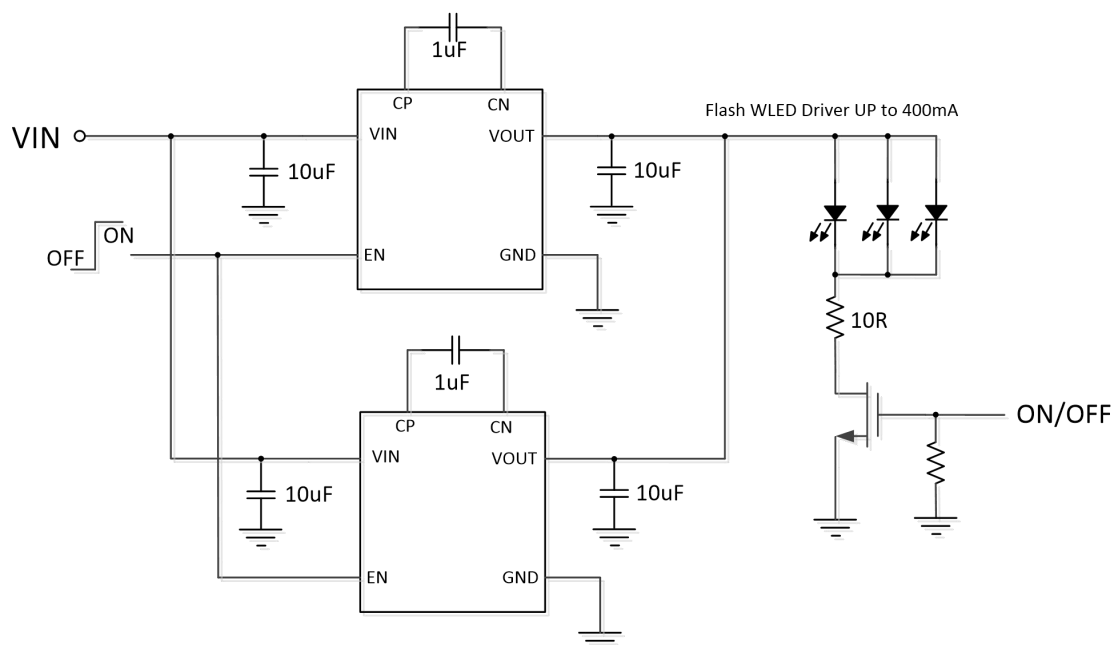
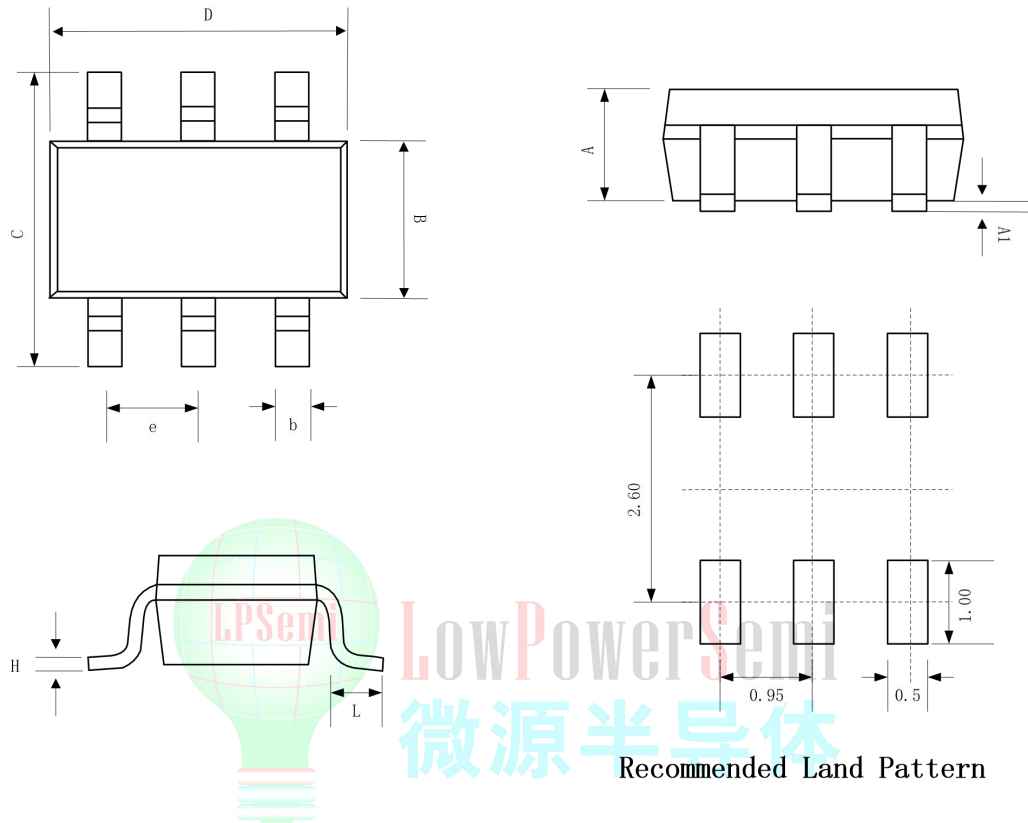

Figure3: Large Current Flash LED Driver from Li-Ion Battery Source

Packaging Information

SOT23-6



SYMBOL	MILLIMETER		
	MIN	NOM	MAX
A	0.889	1.100	1.295
A1	0.000	0.050	0.152
B	1.397	1.600	1.803
b	0.28	0.35	0.559
C	2.591	2.800	3.000
D	2.692	2.920	3.120
e	0.95BSC		
H	0.080	0.152	0.254
L	0.300	0.450	0.610

Tape and Reel Information

REEL DIMENSIONS (Unit:mm)

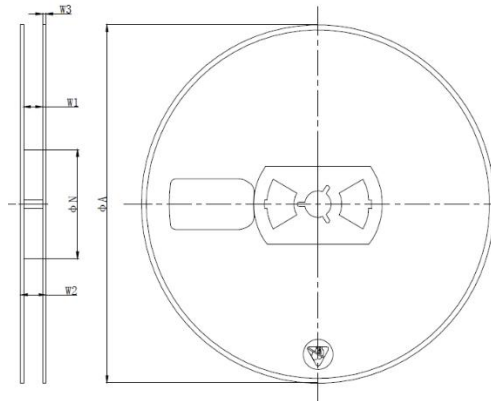

ΦA	W2
180 ± 4	12 ± 0.6

TAPE DIMENSIONS (Unit:mm)

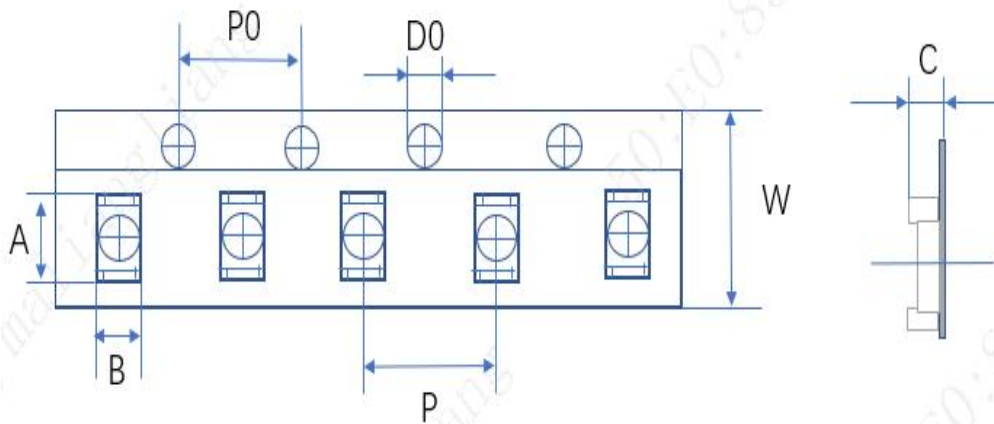

A	B	P0	P	D0	W	C
3.20 ± 0.20	3.26 ± 0.20	4.00 ± 0.10	4.00 ± 0.10	1.50 ± 0.15	8.00 ± 0.30	1.40 ± 0.20

PIN1 AND TAPE FEEDING DIRECTION

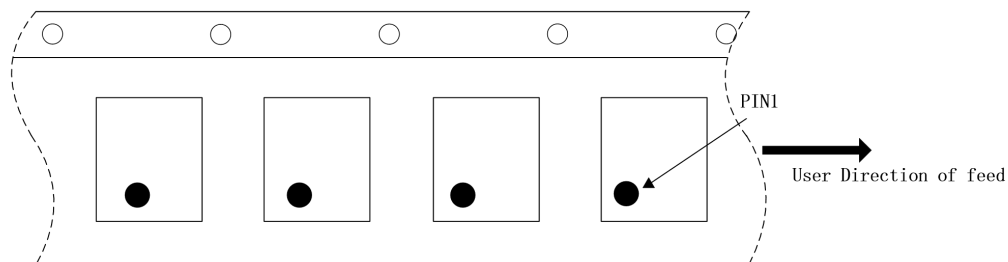

CARTON BOX DIMENSIONS

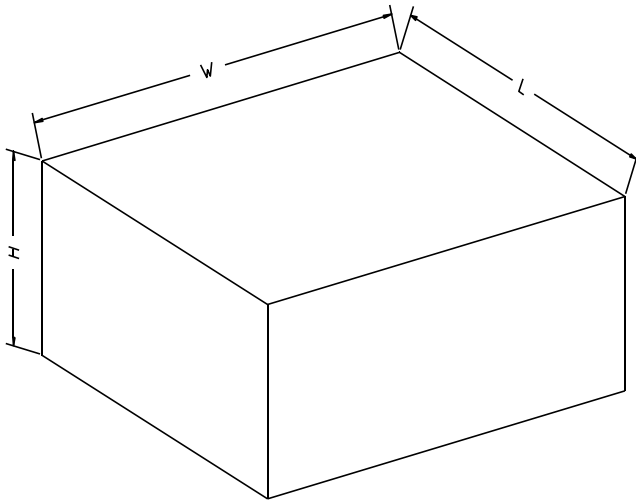

KEY PARAMETER LIST

Reel Type	Carton	Length (mm)	Width (mm)	Height (mm)	Reel/Carton
7"	Inner	210	210	210	10
7"	Outer	445	445	230	40

NOTE: The picture is only for reference. Please make the object as the standard.

Classification of IR Reflow Profile

Profile Feature	Sn-Pb Eutectic Assembly	Pb-Free Assembly
Preheat/Soak		
Temperature Min(T_{SMIN})	100°C	150°C
Temperature Max(T_{SMAX})	150°C	200°C
Time(T_S) from (T_{SMIN} to T_{SMAX})	60~120 seconds	60~120 seconds
Ramp-up rate (T_L to T_P)	3°C/second max	3°C/second max
Liquidous temperature(T_L)	183°C	217°C
Time(t_L) maintained above T_L	60~150 seconds	60~150 seconds
Peak package body temperature (T_P)	For users T_P must not exceed the Classification temp in Table 1. For suppliers T_P must equal or exceed the Classification temp in Table 1.	For users T_P must not exceed the Classification temp in Table 2. For suppliers T_P must equal or exceed the Classification temp in Table 2.
Time(t_p)* within 5°C of the specified classification temperature(T_C), see Figure 1	20* seconds	30* seconds
Ramp-down rate (T_P to T_L)	6°C/second max	6°C/second max
Time 25°C to peak temperature	6 minutes max	8 minutes max
* Tolerance for peak profile temperature (T_P) is defined as a supplier minimum and a user maximum.		

Table 1 Sn-Pb Eutectic Process - Classification Temperatures (T_C)

Package Thickness	Volume mm^3 <350	Volume mm^3 ≥350
<2.5mm	235°C	220°C
≥2.5mm	220°C	220°C

Table 2 Pb-Free Process - Classification Temperatures (T_C)

Package Thickness	Volume mm^3 <350	Volume mm^3 350~2000	Volume mm^3 ≥350
<1.6mm	260°C	260°C	260°C
1.6mm~2.5mm	260°C	250°C	245°C
>2.5mm	250°C	245°C	245°C

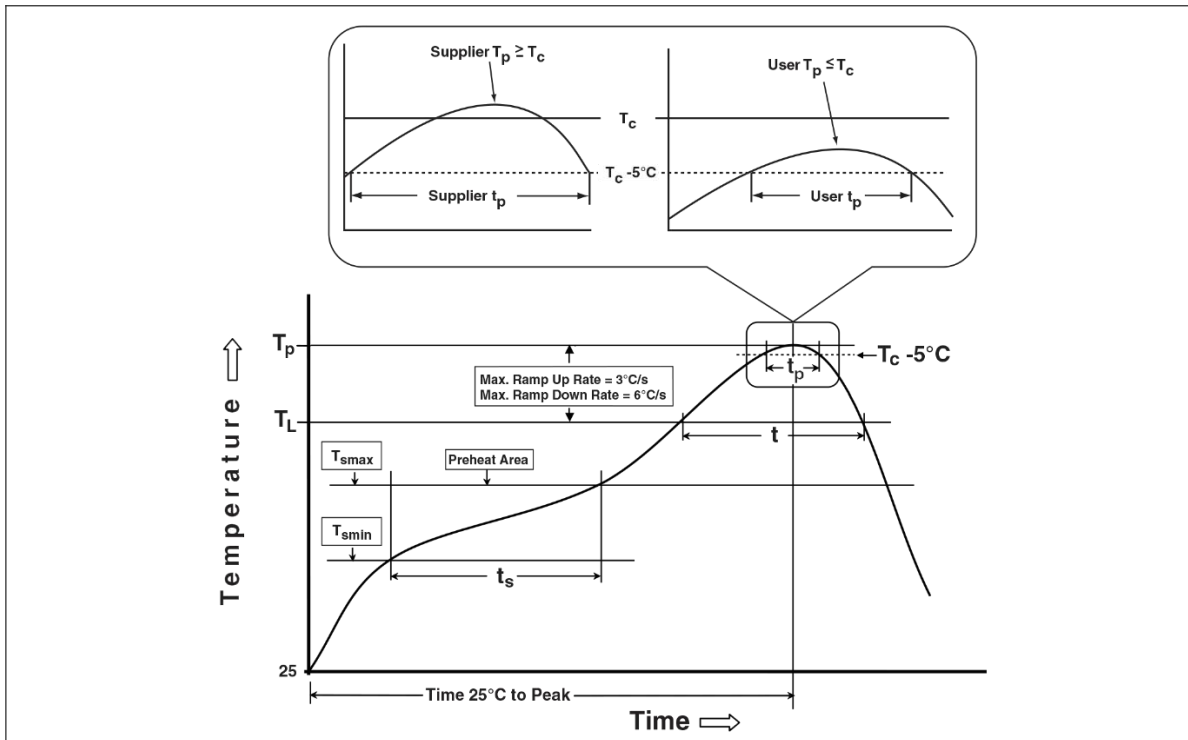

Figure1 Classification Profile (Not to scale)

Products shipped conform to “RoHS” standards;

Moisture Sensitivity Level: MSL3 (CONDITION: $\leq 30^\circ\text{C}/60\%\text{RH}$, Time control:168 hours) ;