

## 500mA, Ultra-low noise, Small Package

### Ultra-Fast CMOS LDO Regulator

### General Description

The LP3980S is designed for portable RF and wireless applications demanding performance and space requirements. The LP3980S performance is optimized for battery-powered systems to deliver ultra low noise and low quiescent current. Regulator ground current increases only slightly in dropout, further prolonging the battery life. The LP3980S also works with low-ESR ceramic capacitors, reducing the amount of board space necessary for power applications, critical in hand-held wireless devices. The LP3980S consumes less than 0.03µA in shutdown mode and has fast turn-on time less than 50µs. The other features include ultra low dropout voltage, high output accuracy, current limiting protection, and high ripple rejection ratio.

### Applications

- ✧ Portable Media Players/MP3 players
- ✧ Cellular and Smart mobile phone
- ✧ LCD
- ✧ DSC Sensor
- ✧ Wireless Card

### Features

- ◆ 1.6V- 6V Input Voltage Range
- ◆ Low Dropout : 240mV @ 300mA
- ◆ 500mA Output Current
- ◆ High PSRR: -76dB at 1KHz
- ◆ < 1uA Standby Current When Shutdown
- ◆ Ultra-Fast Response in Line/Load transient
- ◆ Current Limiting
- ◆ Thermal Shutdown Protection
- ◆ Available in SOT23-5 Package

### Order Information

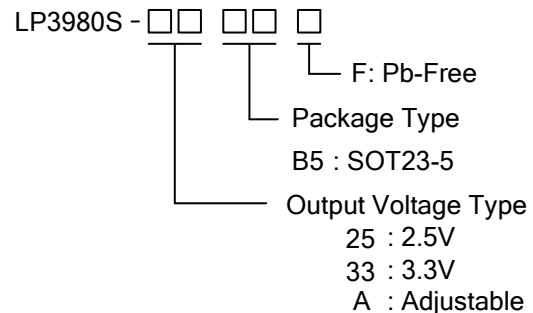

### Marking Information

Device	Marking	Shipping
LP3980S-33B5F	LP3980 33YWX	3K/REEL
LP3980SAB5F	LPS 1FYWX	3K/REEL
Marking indication: Y:Year code .W: W is week code. X: X is series number.		

## Typical Application Circuit

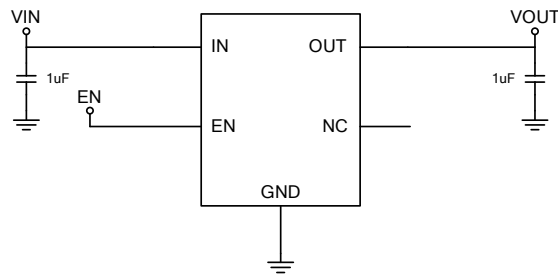

Fixed Voltage Application Circuit

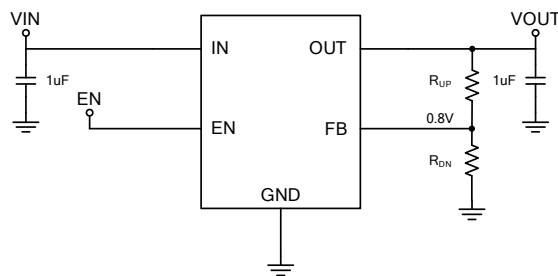

Adjustable Voltage Application Circuit

## Functional Pin Description

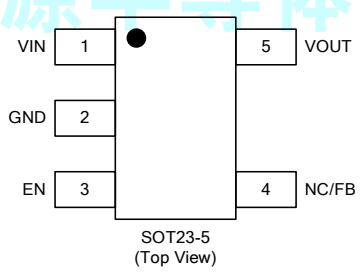
Package Type	Pin Configurations
SOT23-5	 <p style="text-align: center;">SOT23-5 (Top View)</p>

## Pin Description

Pin No.	Name	Description
1	VIN	Power Input voltage.
2	GND	Ground.
3	EN	Enable pin.
4	NC	No connect.
	FB	Feedback pin. The reference voltage is 0.8V. ( LP3980SA5F )
5	VOUT	Output voltage.

## Function Block Diagram

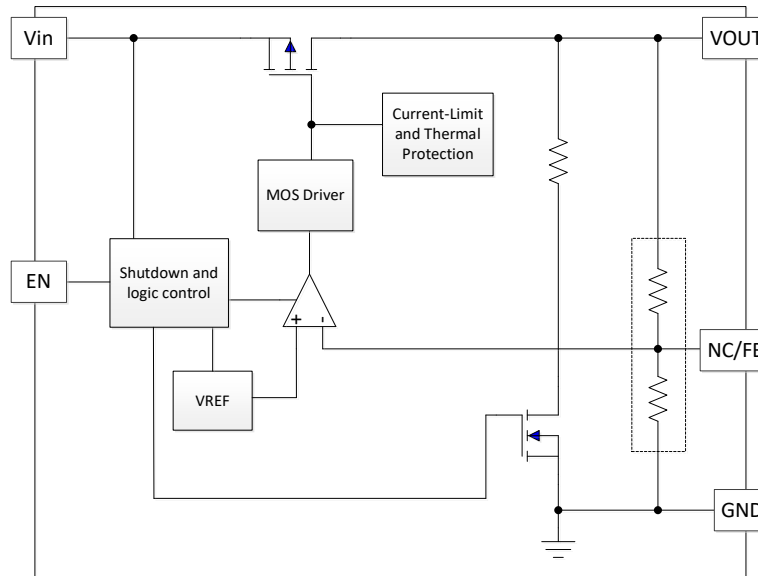

## Absolute Maximum Ratings <sup>Note 1</sup>

◇ Input to GND	-----	-0.3V to 6.5V
◇ EN to GND	-----	-0.3V to 6V
◇ Output Voltage to GND	-----	-0.3V to (VIN+0.3V)
◇ Maximum Junction Temperature	-----	150°C
◇ Operating Ambient Temperature Range (T <sub>A</sub> )	-----	-40°C to 85°C
◇ Maximum Soldering Temperature (At leads, 10 sec)	-----	260°C

**Note 1.** Stresses beyond those listed under “Absolute Maximum Ratings” may cause permanent damage to the device. These are stress ratings only, and functional operation of the device at these or any other conditions beyond those indicated in the operational sections of the specifications is not implied. Exposure to absolute maximum rating conditions for extended periods may affect device reliability.

## Thermal Information

◇ Maximum Power Dissipation (SOT23-5, P <sub>D</sub> , T <sub>A</sub> =25°C)	-----	400mW
◇ Thermal Resistance (SOT23-5, θ <sub>JA</sub> )	-----	250°C/W

## ESD Susceptibility

◇ HBM(Human Body Mode)	-----	2KV
◇ MM(Machine Mode)	-----	200V

## Electrical Characteristics

$V_{IN} = V_{OUT} + 1V$ ,  $C_{IN} = C_{OUT} = 1\mu F$ ,  $T_A = 25^\circ C$ , unless otherwise specified.

Symbol	Parameter	Test Conditions	Min	Typ	Max	Units
$V_{IN}$	Input Voltage		1.6		6	
$V_{OUT}$	Output Voltage	LP3980S-33, $I_{OUT} = 1mA$		3.3		V
		LP3980S-25, $I_{OUT} = 1mA$		2.5		V
$\Delta V_{OUT}$	Output Voltage Accuracy	$I_{OUT} = 1mA$	-1	--	+1	%
$V_{FB}$	Feedback Voltage	$I_{OUT} = 1mA, LP3980AB5F$	0.792	0.8	0.808	V
$I_{LIM}$	Current Limit	$R_{LOAD} = 1\Omega$		650		mA
$I_Q$	Quiescent Current	$V_{EN} \geq 1.2V, I_{OUT} = 0mA$		20		$\mu A$
$V_{DROP}$	Dropout Voltage	$V_{out}=3.3V, I_{OUT} = 200mA$		160	200	mV
		$V_{out}=3.3V, I_{OUT} = 300mA$		240	300	mV
		$V_{out}=3.3V, I_{OUT} = 500mA$		400	500	mV
$\Delta V_{LINE}$	Line Regulation	$V_{IN} = (V_{OUT} + 1V)$ to 5.5V, $I_{OUT} = 1mA$			0.1	%
$\Delta V_{LOAD}$	Load Regulation	$1mA < I_{OUT} < 300mA$			0.6	%
$I_{STBY}$	Standby Current	$V_{EN} = GND$ , Shutdown		0.03	1	$\mu A$
$I_{IBSD}$	EN Input Bias Current	$V_{EN} = GND$ or $V_{IN}$		0.1		$\mu A$
$V_{IL}$	EN Threshold	Logic-Low Voltage			0.4	V
$V_{IH}$		Logic-High Voltage		1.4		V
-	Output Noise Voltage	$f = 10Hz$ to 100kHz, $I_{OUT} = 0mA$ $V_{OUT} = 2.8V$		100		$\mu VRMS$
PSRR	Power Supply Rejection Rate	$f=217Hz$		-80		dB
		$f=1KHz$	$C_{OUT} = 1\mu F, I_{OUT} = 50mA$	-76		dB
$R_{DIS}$	Auto-discharge On-Resistance	$V_{IN} = 5V, V_{EN} = GND$		60		$\Omega$
$T_{SD}$	Thermal Shutdown Temperature			150		$^\circ C$

## Typical Operating Characteristics

Quiescent Current VS. Input Voltage

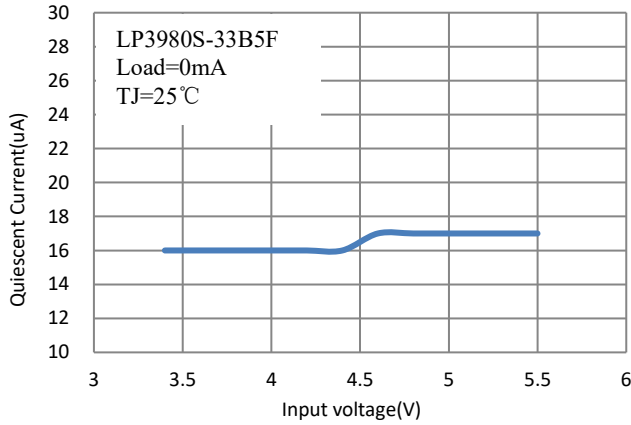

Standby Current VS. Input Voltage

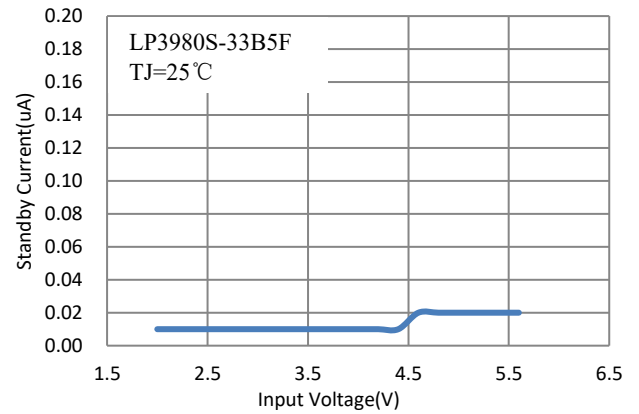

Output Voltage VS. Input Voltage

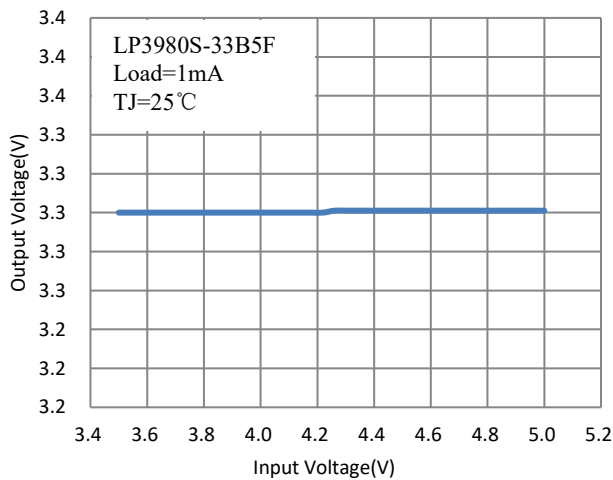

Dropout Voltage VS. Load Current

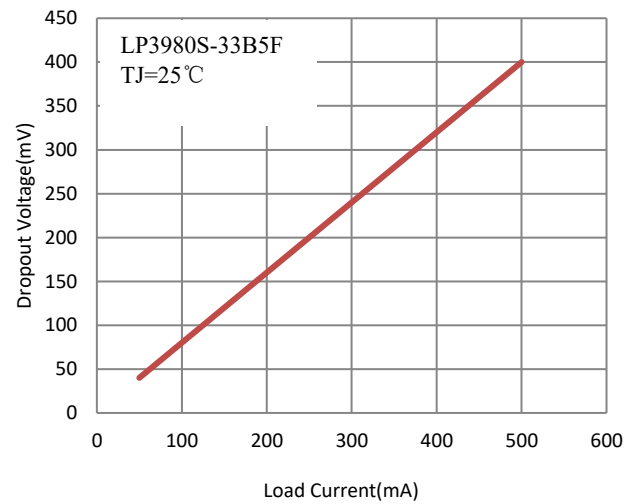

WF  
源

## Applications Information

Like any low-dropout regulator, the external capacitors used with the LP3980S must be carefully selected for regulator stability and performance. Using a capacitor whose value is  $> 1\mu\text{F}$  on the LP3980S input and the amount of capacitance can be increased without limit. The input capacitor must be located a distance of not more than 0.5 inch from the input pin of the IC and returned to a clean analog ground. Any good quality ceramic or tantalum can be used for this capacitor. The capacitor with larger value and lower ESR (equivalent series resistance) provides better PSRR and line-transient response. The output capacitor must meet both requirements for minimum amount of capacitance and ESR in all LDOs application. The LP3980S is designed specifically to work with low ESR ceramic output capacitor in space-saving and performance consideration. Using a ceramic capacitor whose value is at least  $1\mu\text{F}$  with ESR is  $> 25\text{m}\Omega$  on the LP3980S output ensures stability. The LP3980S still works well with output capacitor of other types due to the wide stable ESR range. Output capacitor of larger capacitance can reduce noise and improve load transient response, stability, and PSRR. The output capacitor should be located not more than 0.5 inch from the VOUT pin of the LP3980S and returned to a clean analog ground.

### Enable Function

The LP3980S features an LDO regulator enable/disable function. To assure the LDO regulator will switch on, the EN turn on control level must be greater than 1.4 volts. The LDO regulator will go into the shutdown mode when the voltage on the EN pin falls below 0.4 volts. For protecting the system, the LP3980S have a quick-discharge function. If the enable function is not needed in a specific application, it may be tied to VIN to keep the LDO regulator in a continuously on state.

### Thermal Considerations

Thermal protection limits power dissipation in LP3980S. When the operation junction temperature exceeds  $150^\circ\text{C}$ , the OTP circuit starts the thermal shutdown function turn the pass element off. The pass element turns on again after the junction temperature cools by  $20^\circ\text{C}$ . For continue operation, do not exceed absolute maximum operation junction temperature  $125^\circ\text{C}$ .

The power dissipation definition in device is :

$$P_D = (V_{IN} - V_{OUT}) \times I_{OUT} + V_{IN} \times I_Q$$

The maximum power dissipation depends on the thermal resistance of IC package, PCB layout, the rate of surroundings airflow and temperature difference between junctions to ambient.

The maximum power dissipation can be calculated by following formula:

$$P_{D(\text{MAX})} = (T_{J(\text{MAX})} - T_A) / \theta_{JA}$$

Where  $T_{J(MAX)}$  is the maximum operation junction temperature  $125^{\circ}\text{C}$ ,  $T_A$  is the ambient temperature and the  $\theta_{JA}$  is the junction to ambient thermal resistance. For recommended operating conditions specification of LP3980S, where  $T_{J(MAX)}$  is the maximum junction temperature of the die ( $125^{\circ}\text{C}$ ) and  $T_A$  is the maximum ambient temperature. The junction to ambient thermal resistance ( $\theta_{JA}$  is layout dependent) for SOT23-5 package is  $250^{\circ}\text{C}/\text{W}$ .

$$P_{D(MAX)} = (125^{\circ}\text{C} - 25^{\circ}\text{C}) / 250 = 400\text{mW (SOT23-5)}$$

The maximum power dissipation depends on operating ambient temperature for fixed  $T_{J(MAX)}$  and thermal resistance  $\theta_{JA}$ .



## Packaging Information

### SOT23-5

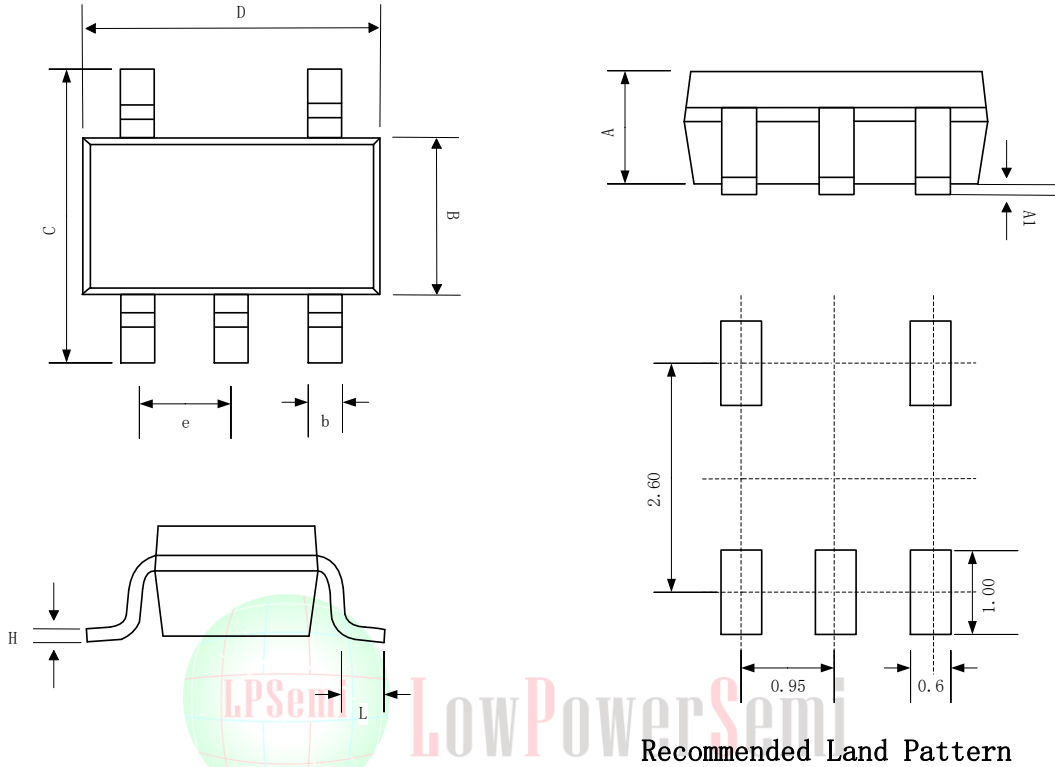

SYMBOL	Dimensions In Millimeters		
	MIN	NOM	MAX
A	0.889	1.100	1.295
A1	0.000	0.050	0.152
B	1.397	1.600	1.803
b	0.28	0.35	0.559
C	2.591	2.800	3.000
D	2.692	2.920	3.120
e	0.95BSC		
H	0.080	0.152	0.254
L	0.300	0.450	0.610

## Tape and Reel Information

### REEL DIMENSIONS

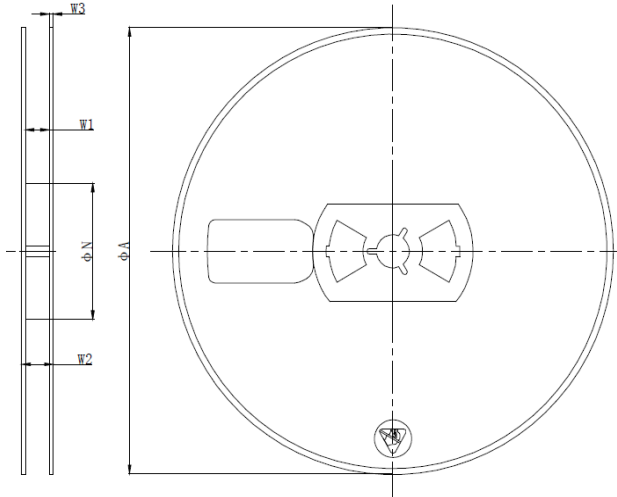

SYMBOL	Dimensions In Millimeters		
	MIN	NOM	MAX
$\phi A$	176.00	180.00	184.00
W2	10.00	12.00	14.00

### TAPE DIMENSIONS

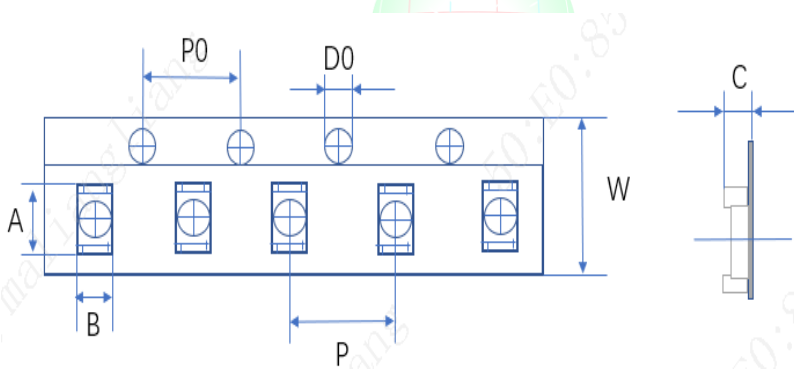

SYMBOL	Dimensions In Millimeters		
	MIN	NOM	MAX
A	3.00	3.20	3.40
B	3.06	3.26	3.46
P0	3.90	4.00	4.10
P	3.90	4.00	4.10
D0	1.35	1.50	1.65
W	7.70	8.00	8.30
C	1.20	1.40	1.60

### PIN1 AND TAPE FEEDING DIRECTION

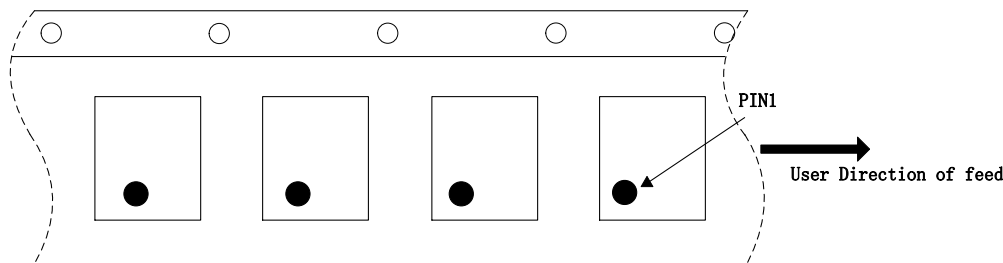

## Classification of IR Reflow Profile

Profile Feature	Sn-Pb Eutectic Assembly	Pb-Free Assembly
<b>Preheat/Soak</b>		
Temperature Min( $T_{SMIN}$ )	100°C	150°C
Temperature Max( $T_{SMAX}$ )	150°C	200°C
Time( $T_s$ ) from ( $T_{SMIN}$ to $T_{SMAX}$ )	60~120 seconds	60~120 seconds
Ramp-up rate ( $T_L$ to $T_P$ )	3°C/second max	3°C/second max
Liquidous temperature( $T_L$ )	183°C	217°C
Time( $t_L$ ) maintained above $T_L$	60~150 seconds	60~150 seconds
Peak package body temperature ( $T_P$ )	For users $T_P$ must not exceed the Classification temp in Table 1. For suppliers $T_P$ must equal or exceed the Classification temp in Table 1.	For users $T_P$ must not exceed the Classification temp in Table 2. For suppliers $T_P$ must equal or exceed the Classification temp in Table 2.
Time( $t_P$ )* within 5°C of the specified classification temperature( $T_C$ ), see Figure1	20* seconds	30* seconds
Ramp-down rate ( $T_P$ to $T_L$ )	6°C/second max	6°C/second max
Time 25°C to peak temperature	6 minutes max	8minutes max
* Tolerance for peak profile temperature ( $T_P$ ) is defined as a supplier minimum and a user maximum.		

**Table 1 Sn-Pb Eutectic Process - Classification Temperatures ( $T_C$ )**

Package Thickness	Volume mm <sup>3</sup> <350	Volume mm <sup>3</sup> ≥350
<2.5mm	235°C	220°C
≥2.5mm	220°C	220°C

**Table 2 Pb-Free Process - Classification Temperatures ( $T_C$ )**

Package Thickness	Volume mm <sup>3</sup> <350	Volume mm <sup>3</sup> 350~2000	Volume mm <sup>3</sup> ≥350
<1.6mm	260°C	260°C	260°C
1.6mm~2.5mm	260°C	250°C	245°C
>2.5mm	250°C	245°C	245°C

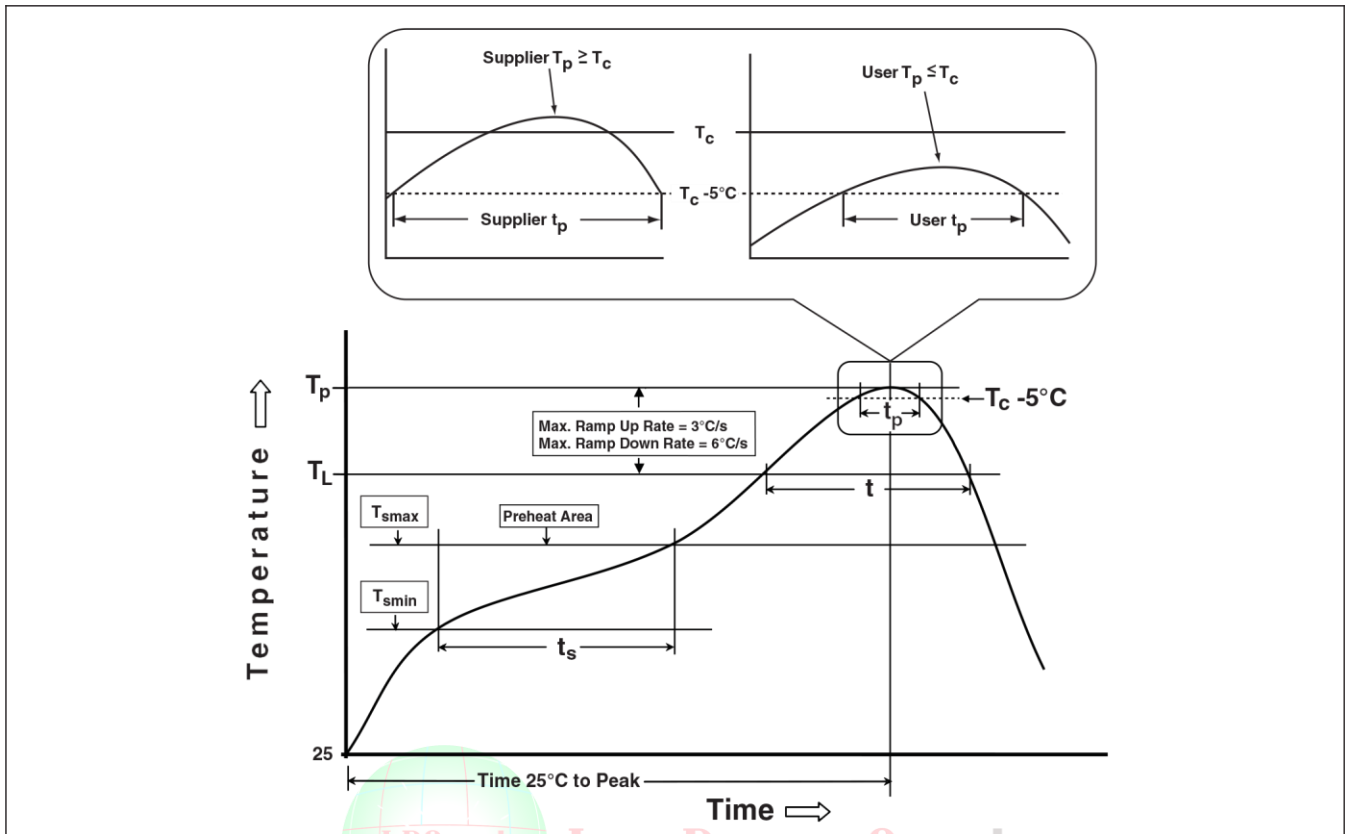

Figure1 Classification Profile (Not to scale)

Products conform to “JEDEC J-STD-020C” standards;

Products shipped conform to “Rohs” standards;

Moisture Sensitivity Level: MSL3 (CONDITION:  $\cong 30\text{ }^\circ\text{C}/60\%\text{RH}$ 、Time control:168 hours) ;