

Features

- Easy-to-use standalone 4/5/6-cell Boost charger
 - Proprietary sensorless charge current control
 - 4.5V to 13.5V input voltage operation
 - 20V absolute maximum input voltage rating
 - Charge voltages: $N \times (4.15V/4.2V/4.3V/4.35V)$ (N is the number of battery cells, $N=4-6$)
 - 0.3A -1.0A programmable fast charge current
 - 600kHz switching frequency
 - 10 μ H inductor
 - Support Precharge, Constant Current (CC) charge, Constant Voltage (CV) charge, charge termination and recharge
- High charge accuracy
 - +/- 0.75% charge voltage regulation
 - +/- 10% charge current regulation
 - 150mA precharge current
 - 150mA termination current
- Protections
 - Cycle-by-cycle current limit protection
 - Input voltage regulation (VINDPM)
 - Cold/hot battery temperature monitoring
 - Junction temperature thermal regulation(TREG)
 - Over junction temperature protection
- Packaging
 - ESOP-8L
 - RoHS compliant and halogen free
 - 100% lead (Pb) free

Applications

- Multi-cell battery charger
- Power tools
- Drones
- E-bike
- E-scooters
- Handheld vacuum cleaners
- Portable blowers
- Robotics

General Description

The LP41324/5/6 is a cost-effective standalone Boost 4-cell to 6-cell battery charger. The fast charge current is programmable up to 1A with input voltage up to 10.5V. Adjustable USB-PD voltages 5V/9V or PPS can be used to charge a 4 to 6-cell battery based on actual battery voltage. Higher input voltage supports higher charge current because of higher charge efficiency and fast charge current is also programmable based on USB input voltage and battery voltage. The charge status is indicated by STAT pin driving a LED in series with a current limit resistor. The LP41324/5/6 features battery temperature monitoring and protection based on NTC temperature sensing.

The LP41324/5/6 offers ESOP-8L package.

Order Information

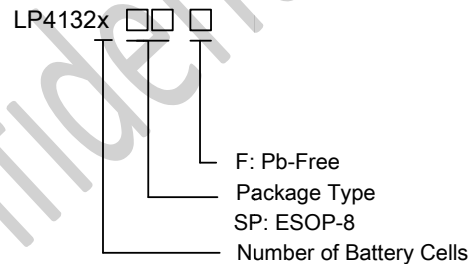

Application Circuit

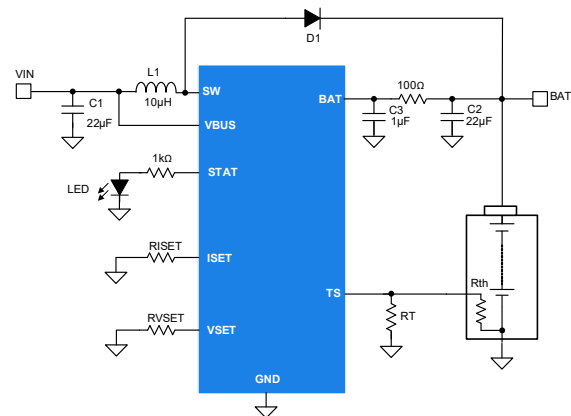

Device Information

Part Number	Battery cells	Battery Voltages	Top Marking	Package	Moisture Sensitivity Level	Shipping
LP41324SPF	4	16.6/16.8/17.2/17.4V	LPS LP41324 YWX	ESOP-8L	MLS3	4K/REEL
LP41325SPF	5	20.75/21/21.5/21.75V	LPS LP41324 YWX	ESOP-8L	MLS3	4K/REEL
LP41326SPF	6	24.9/25.2/25.8/26.1V	LPS LP41324 YWX	ESOP-8L	MLS3	4K/REEL

Marking indication: Y: Year code. W: Week code. X: Batch numbers.

Input Voltage, Charge Current and Inductance

Input Voltage	Battery Cells	4-cell	5-cell	6-cell
5V	Inductance	6.8 μ H	6.8 μ H	10 μ H
	Charge current	0.3A-0.8A	0.3A-0.7A	0.3A-0.5A
9V	Inductance	10 μ H	10 μ H	10 μ H
	Charge current	0.3A-1A	0.3A-1A	0.3A-0.8A
12V	Inductance	10 μ H	10 μ H	10 μ H
	Charge current	0.3A-1A	0.3A-1A	0.3A-1A

Pin Diagram

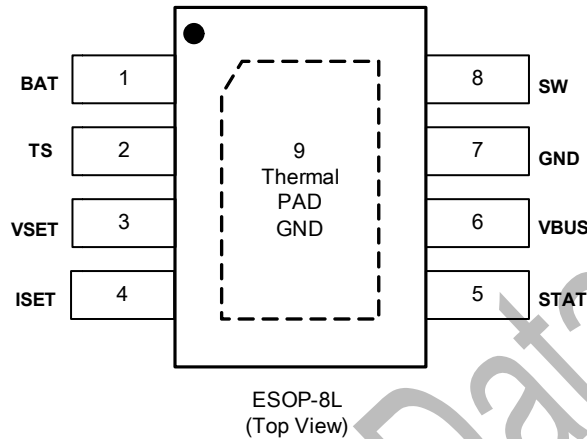

Pin Description

Pin Name	ESOP-8L	Description
BAT	1	Battery voltage sense input
TS	2	Battery temperature sense thermistor input. Charge is suspended if the battery thermistor temperature is out of range. If TS pin is not used, connect TS pin to GND. If TS pin is floating, termination is disabled.
VSET	3	Battery charge voltage program input.
ISET	4	Charge current program input. Connect a 1% resistor R _{ISET} from this pin to ground to program the charge current. If ISET pin is floating, charge current is minimized. If ISET pin is pulled below 0.5V, charge is disabled.
STAT	5	Charge status indication output. Connect a LED from STAT pin to GND via a current limiting resistor. The STAT pin indicates charge status: Charge in progress: STAT pin is pulled high to an internal supply Charge complete or not in charge: STAT pin is internally open.
VBUS	6	Device input voltage
GND	7	Ground. Connect to thermal pad from the top layer.
SW	8	Switching node. Connect to a terminal of inductor.
Thermal PAD & GND	9	Thermal pad and ground. Connected to ground plane.

Absolute Maximum Ratings ^(Note)

VBUS Voltage to GND	-----	-0.3V to 20V
SW and BAT Voltage to GND	-----	-0.3V to 30V
STAT, ISET, TS, VSET Voltages to GND	-----	-0.3V to 6V
STAT Source Current	-----	6mA
Maximum Junction Temperature (T _J)	-----	150°C
Storage Temperature Range	-----	-40°C to 150°C
Maximum Soldering Temperature (at leads, 10 sec)	-----	260°C

Note: Stresses beyond those listed under “Absolute Maximum Ratings” may cause permanent damage to the device. These are stress ratings only, and functional operation of the device at these or any other conditions beyond those indicated in the operational sections of the specifications is not implied. Exposure to absolute maximum rating conditions for extended periods may affect device reliability.

ESD Ratings

HBM (Human Body Model)	-----	2kV
MM (Machine Model)	-----	200V
CDM (Charge Discharge Model)	-----	500V

Thermal Information

θ _{JA} (Junction-to-Ambient Thermal Resistance) for ESOP-8L	-----	48°C/W
--	-------	--------

Recommended Operating Conditions

SYMBOL	PARAMETER	MIN	TYP	MAX	UNIT
V _{IN}	Input Voltage (V _{BAT} > V _{IN})	4.5		13.5	V
I _{CHG}	Fast Charge Current	0.3		1.0	A
V _{BATREG}	Battery Charge Voltage	16.6		26.1	V
T _J	Operating Junction Temperature Range (T _J)	-40		125	°C
T _A	Ambient Temperature Range	-40		85	°C

Recommended Component Parameter Range ⁽¹⁾

SYMBOL	PARAMETER	MIN	TYP	MAX	UNIT
C _{VBUS}	Input Capacitance at VBUS	6	22		μF
C _{BAT}	BAT Capacitance ⁽¹⁾	6	22		μF
L1	Boost Inductance ⁽¹⁾	5.5	10		μH

Notes:

(1) The values recommended in the table are effective inductance and capacitance.

Electrical Characteristics

(The specifications are at $V_{VBUS} = 5V$, $V_{BAT} = 0.9 * V_{BATREG}$, $T_J = 25^{\circ}C$ unless otherwise noted)

SYMBOL	PARAMETER	TEST CONDITIONS	MIN	TYP	MAX	UNIT
QUIESCENT CURRENT						
I_{Q_BAT}	Battery reverse current	No VBUS $V_{BAT} = V_{BATREG}$			3	μA
I_{Q_BAT}	Battery leak current at termination	Charge is terminated, $V_{BAT} = V_{BATREG}$			20	μA
I_{Q_BAT}	Battery leak current at ISET pin short	Charge is disabled, $V_{BAT} = V_{BATREG}$			20	μA
INPUT VOLTAGE AND CURRENT						
V_{UVLO_RISE}	Under voltage lock out(UVLO) voltage	V_{VBUS} rising		3.8		V
V_{UVLO_FALL}	UVLO voltage	V_{VBUS} falling		300		mV
V_{OP_MIN}	Minimum operation input voltage	V_{VBUS} rising			4.5	V
V_{INDPM}	VINDPM at VBUS	Regulated at VBUS pin		4.35	4.5	V
BOOST CONVERTER						
R_{DSON_Q1}	Boost NFET on-resistance	$V_{VBUS} = 5V$		80		m Ω
f_{SW}	Switching frequency			600		kHz
I_{OCP1}	Over current limit			5.5		A
D_{MAX}	Maximum duty cycle			92		%
I_{PK_MIN}	Minimum peak inductor current			0.7		A
V_{SCP_FALL}	Boost short circuit detection	$V_{SCP} = (V_{VBUS} - V_{BAT})$ V_{BAT} falling, Boost disabled		0.80		V
V_{SCP_RISE}	Boost short circuit detection	$V_{SCP} = V_{VBUS} - V_{BAT}$ V_{BAT} rising, Boost startup		0.50		V

Electrical Characteristics

(The specifications are at $V_{VBUS} = 5V$, $V_{BAT} = 0.9 * V_{BATREG}$, $T_J = 25^\circ C$ unless otherwise noted)

ISET CHARGE CURRENT SETTING						
V_{ISET}	ISET pin voltage		0.985	1	1.015	V
I_{CHG}	Charge current setting range		0.3		1.2	A
K_{ICHG}	Charge current ratio			40		AxkΩ
V_{ISET_SHORT}	ISET pin short protection threshold			0.5		V
STAT INDICATION						
V_{STAT}	STAT pull-up voltage	STAT internally pulled up to V_{STAT} $V_{BUS} = 5V, I_{STAT} = 0$	4.5	5		V
V_{STAT}	STAT pull-up voltage	STAT internally pulled up to V_{STAT} $V_{BUS} = 5V, I_{STAT} = 6mA$	4.0	4.5		V
I_{SAT_SOURCE}	STAT source current capability		6			mA
COLD/HOT THERMISTOR COMPARATOR						
I_{TS_SOURCE}	TS pin pull-up current			100		uA
V_{TS_FLT}	TS floating detect	$V_{VBUS} = 5V$ Termination is disabled		4.5		V
V_{TS_GND}	TS ground detect	$V_{VBUS} = 5V$ TS function not in use when grounded		0.15	0.2	V
V_{T1_HOT}	TS hot threshold	V_{TS} falling		500		mV
V_{T1_HOT}	TS hot threshold	V_{TS} rising		550		mV
V_{T3_COLD}	TS cold threshold	V_{TS} rising		2500		mV
V_{T3_COLD}	TS cold threshold	V_{TS} falling		2250		mV

Electrical Characteristics

(The specifications are at $V_{VBUS} = 5V$, $V_{BAT} = 0.9 * V_{BATREG}$, $T_J = 25^\circ C$ unless otherwise noted)

SYMBOL	PARAMETER	TEST CONDITIONS	MIN	TYP	MAX	UNIT
BATTERY CHARGER						
V_{BATREG}	Charge voltage (4 cells)	VSET pin open ($R_{VSET} > 200k\Omega$)		16.6		V
		VSET shorted to GND ($R_{VSET} < 510\Omega$)		16.8		V
		$R_{VSET} = 51 k\Omega \pm 10\%$		17.2		V
		$R_{VSET} = 10k\Omega \pm 10\%$		17.4		V
V_{BATREG}	Charge voltage (5 cells)	VSET pin open ($R_{VSET} > 200k\Omega$)		20.75		V
		VSET shorted to GND ($R_{VSET} < 510\Omega$)		21		V
		$R_{VSET} = 51 k\Omega \pm 10\%$		21.5		V
		$R_{VSET} = 10k\Omega \pm 10\%$		21.75		V
V_{BATREG}	Charge voltage (6 cells)	VSET pin open ($R_{VSET} > 200k\Omega$)		24.9		V
		VSET shorted to GND ($R_{VSET} < 510\Omega$)		29.4		V
		$R_{VSET} = 51 k\Omega \pm 10\%$		30.1		V
		$R_{VSET} = 10k\Omega \pm 10\%$		30.45		V
$V_{BAT_LOWV_RISE\%}$	V_{BAT} fast charge rising threshold	Precharge to fast charge threshold, as percentage of V_{BATREG} , V_{BAT} rising		68		%
$V_{BAT_LOWV_FALL\%}$	V_{BAT} fast charge falling threshold	Fast charge to precharge charge threshold, as percentage of V_{BATREG} , V_{BAT} falling		66		%
$V_{RECHG_RISE\%}$	Recharge threshold	As percentage of V_{BATREG} , V_{BAT} rising		98		%
$V_{RECHG_FALL\%}$	Recharge threshold	As percentage of V_{BATREG} , V_{BAT} falling		97.6		%
I_{CHG_CC}	Fast charge current	$I_{CHG} = 1A$, $V_{BAT} = 0.9 * V_{BATREG}$, $I_{CHG} = 1A$		1000		mA
I_{CHG_CC}	Fast charge current	$I_{CHG} = 0.5A$, $V_{BAT} = 0.9 * V_{BATREG}$, $I_{CHG} = 0.5A$		500		mA
I_{PRECHG}	Precharge current	$V_{BAT} = 5V$		150		mA
I_{TERM}	Termination current			150		mA

Electrical Characteristics

(The specifications are at $V_{VBUS} = 5V$, $V_{BAT} = 11.4V$, $T_J = 25^\circ C$ unless otherwise noted)

THERMAL REGULATION AND THERMAL SHUTDOWN					
T_{REG1}	Boost mode thermal regulation			118	$^\circ C$
T_{SHUT_RISE}	Thermal shut down in all conditions	Temperature rising		150	$^\circ C$
T_{SHUT_HYST}	Thermal shut down in all conditions	Temperature falling		30	$^\circ C$
TIMING REQUIREMENTS					
t_{DELAY}	Input debounce time	Time delay from V_{UVLO_RISE} to Boost startup		20	ms
t_{SOFT}	Boost soft-start time			5.0	ms
$t_{BATLOWV}$	Precharge and fast charge detection deglitch time			200	us
t_{TERM}	Termination deglitch time			200	ms
t_{RECHG}	Recharge deglitch time			3.0	ms
t_{TS}	TS deglitch time			10	ms
t_{VBUS_OVP}	Input OVP detection time	From V_{VBUS} reaches OVP threshold to Boost switching stop		600	ns
t_{SCP1}	Out of Boost mode delay time	$(V_{VBUS} - V_{BAT}) > V_{SCP_RISE}$		200	ns
t_{SCP2}	Into Boost mode deglitch time	$(V_{VBUS} - V_{BAT}) < V_{SCP_FALL}$		1	ms



Typical Characteristics

(The schematic is as shown in Figure xx)

TBD

LPS Preliminary Datasheet
LPS Confidential

Functional Block Diagram

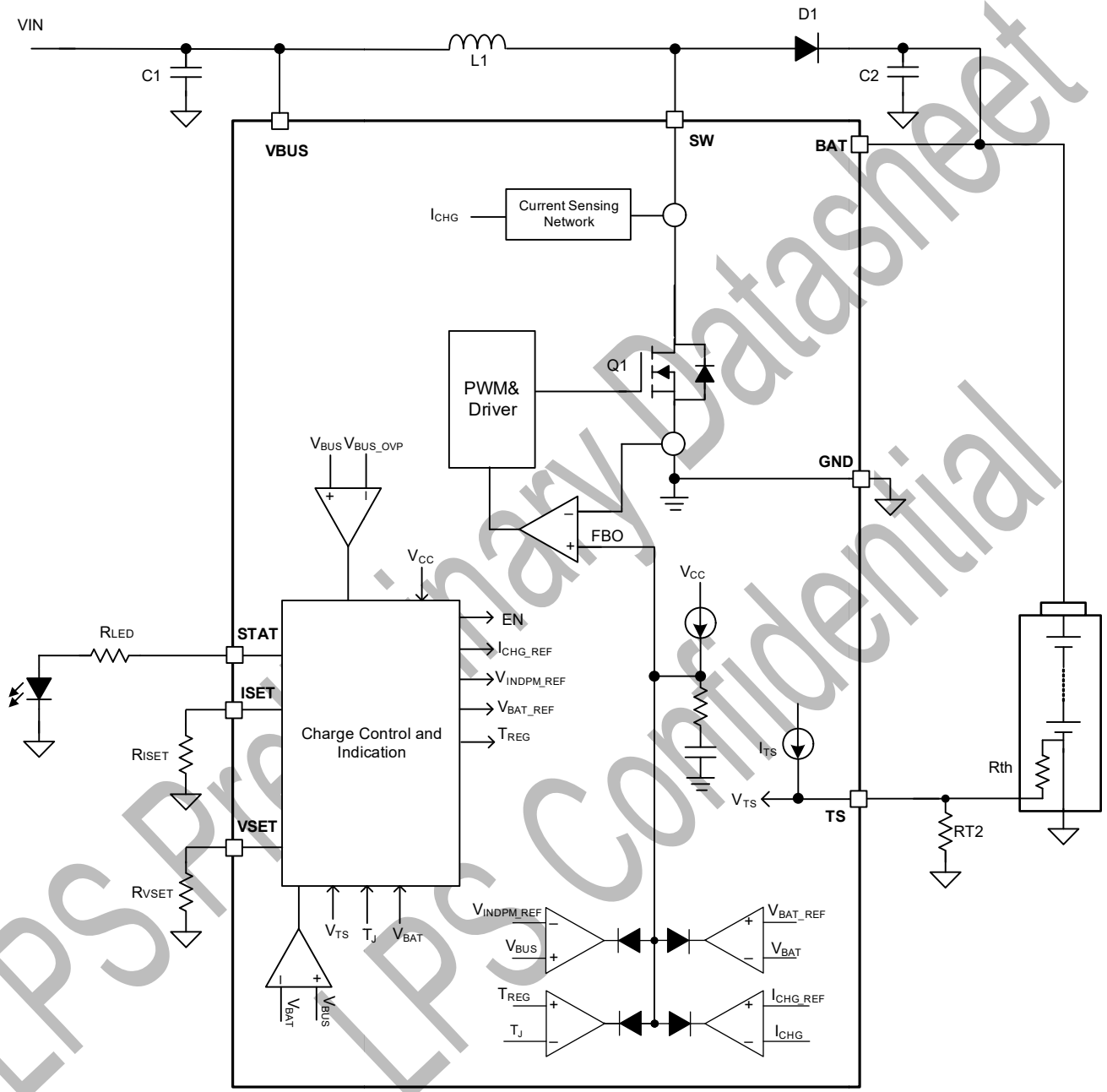

Boost Battery Charger

Detailed Description

Overview

The LP41324/5/6 is a cost-effective standalone 4/5/6-cell Boost switching battery charger that steps 4.5V-13.5V input voltage up to charge 5-cell batteries. The fast charge current is programmable by a resistor at ISET pin from 0.3A to 1A. The battery charge voltage (CV voltage) can be programmed by a resistor connected at VSET pin. The switching frequency is 600kHz and a 6.8uH or 10uH inductor is recommended. Charge status is indicated by STAT pin driving a LED in series with a current limit resistor. The LP41324/5/6 has built-in battery temperature monitoring and protection based on NTC temperature sensing.

Charger Power-up

With VBUS voltage rise above V_{UVLO_RISE} , following a delay time of t_{DELAY} , if the voltage difference between V_{VBUS} and V_{BAT} is $(V_{VBUS} - V_{BAT})$ below V_{SCP_FALL} and VBUS is higher than UVLO threshold, Boost converter starts with charge current ramping up.

Device Functional Mode

The device operates in different modes depending on V_{VBUS} , V_{BAT} and ISET pin connection. The functional modes are listed in the following table.

Table 1: Device Functional Mode

MODE	CONDITIONS	CHARGE	STAT
HiZ Mode	$V_{VBUS} < V_{UVLO}$	NO	OPEN
Boost Disabled	$(V_{VBUS} - V_{BAT}) > V_{SCP_RISE}$	NO	OPEN
VINDPM Mode	$V_{VBUS} = V_{INDPM}$	YES	HIGH
Boost Mode	$(V_{VBUS} - V_{BAT}) < V_{SCP_FALL}$ and $V_{VBUS} > V_{UVLO}$	YES	HIGH
Precharge Mode	$(V_{VBUS} - V_{SCP_FALL}) < V_{BAT} < V_{BAT_LOWV}$	YES	HIGH
Fast Charge Mode	$V_{BAT} > V_{BAT_LOWV}$	YES	HIGH
Charge Termination	$I_{CHG} < I_{TERM}$ $V_{BAT} > V_{RECHG_RISE\%}$ of V_{BAT}	NO	OPEN
Fault Mode	<ul style="list-style-type: none"> • $T_J > T_{SHUT}$ • TS Cold/Hot • Input OVP 	NO	OPEN
ISET Short	ISET pin short to GND	No	OPEN

Boost Converter

The Boost converter is allowed to operate if $V_{VBUS} > V_{UVLO}$ and $V_{VBUS} < V_{SCP_FALL} + V_{BAT}$ and faults is not detected. The Boost converter is under control of input voltage, constant current, thermal regulation, battery voltage regulation loops and only one of the loops controls Boost duty cycle at one time.

Battery Charge Profile

The battery charger builds in Precharge, Constant Current (CC) charge, Constant Voltage (CV) charge, charge termination and recharge. The battery charger starts to operate once battery voltage rises to 0.5V below V_{VBUS} voltage. The charging phase depends on the battery voltage and charge current.

Precharge

The device charges the battery at 150mA in precharge mode if a battery voltage is below 66% of V_{BATREG} .

Constant Current (CC) Charge

CC charge is also called fast charge. The device charges the battery from Boost converter at current level of K_{ICHG} / R_{ISET} , where K_{ICHG} is the gain of charge current setting and R_{ISET} is the resistance value from ISET to GND.

Constant Voltage (CV) Charge

With the battery voltage charged up, the BAT pin voltage reaches the battery regulation voltage V_{BATREG} and the charge current starts to decrease from fast charge current $I_{\text{CHG_CC}}$. The actual battery voltage keeps increasing and charge current decreasing until charge termination conditions are met and charge is terminated.

Charge Termination

The device terminates a charge cycle when the battery voltage is above recharge threshold $V_{\text{BATREG}} * V_{\text{RECHG_RISE\%}}$ and the charge current is below termination current I_{TERM} for deglitch time t_{TERM} . The termination current threshold I_{TERM} is fixed at 150mA.

Battery Recharge

Once a charge cycle is terminated, if battery voltage V_{BAT} decreases below the recharge threshold $V_{\text{BATREG}} * V_{\text{RECHG_FALL\%}}$ and the charge conditions are met, the charger is enabled again. In addition to recharge, a charge cycle starts if V_{VBUS} voltage is recycled or TS fault is cleared. Each time when battery is recharged, a Boost soft-start is inserted.

Boost Short Circuit

If the device detects a battery voltage below $(V_{\text{VBUS}} - V_{\text{SCP_FALL}})$, the short circuit current is bypassed from input supply through inductor and schottky diode. The device does not limit the short circuit current. Instead, when short circuit is detected, the Boost converter turns off and waits until V_{BAT} rises to a threshold of $(V_{\text{VBUS}} - V_{\text{SCP_RISE}})$. Battery pack itself provides short circuit protection if a battery packs is shorted to GND externally. The AC or DC adaptors usually build short circuit protection with constant output current limit or over current protection (OCP), which prevents battery over charge.

ISET Pin Short

If ISET pin is open, the charge current is minimized. If ISET pin is shorted to GND, internal charge current is clamped and charge is disabled. STAT pin is open. ISET pin can be used as enable input for charge enable or disable. An open-drain GPIO in parallel with R_{ISET} can be connected to ISET pin to enable and disable charge. When ISET pin is released from short, the charger goes through soft-start process.

Input Voltage Dynamic Power Management (VINDPM)

When the input current of the device exceeds the current capability of the power supply, the charger device regulates VBUS voltage by reducing charge current to avoid crashing the input power supply. To charge a battery, the input voltage must be higher than actual V_{INDPM} threshold. In VINDPM regulation, termination is temporarily disabled. VINDPM is enabled once Boost converter is in operation

Battery Temperature Monitoring

The charger device provides a single NTC thermistor input TS pin for battery temperature monitor. TS pin has internal pull-up current 100μA and TS voltage is internally clamped. If TS pin is open or pulled higher than a threshold, charge termination is disabled. If TS pin is pulled to ground, TS pin is ignored and battery is charged without TS detection.

The device continuously monitors battery temperature by sensing the voltage at TS pin. The cold temperature is corresponding to the voltage threshold of V_{T3_COLD} and the hot temperature is corresponding to the voltage threshold of V_{T1_HOT} . If the TS voltage V_{TS} falls between V_{T1_HOT} and V_{T3_COLD} , device charges battery normally. If the TS voltage V_{TS} falls out of the range and the TS pin is not shorted to GND or left open, the device stops charge.

As shown in Figure 10, to monitor the battery temperature, a negative temperature coefficient (NTC) thermistor is connected to TS pin through R_{T1} and R_{T2} resistors. The R_{T1} and R_{T2} resistors are used to adjust cold and hot temperatures.

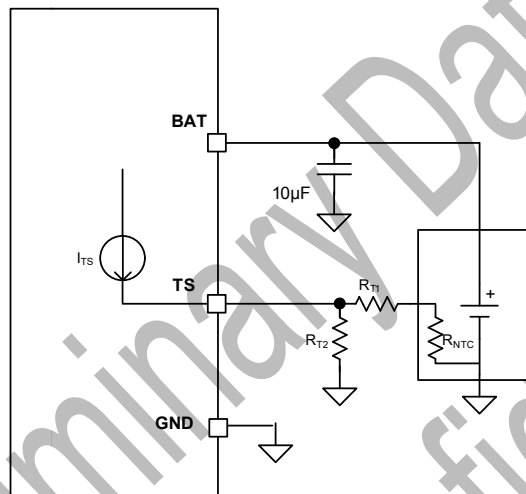

Figure 1. Battery Temperature Monitoring

The R_{T1} and R_{T2} resistance can be calculated based on NTC specifications and charge temperature range. The design steps are as shown below:

1. Convert the cold voltage threshold $V_{T3_COLD_R}$ to a corresponded resistor value using the equation below:

$$R_{COLD} = \frac{V_{T3_COLD_R}}{I_{TS_SOURCE}} = \frac{2500mV}{100\mu A} = 25k\Omega$$

Convert the hot voltage threshold $V_{T1_HOT_F}$ to a corresponded resistor value using the equation below:

$$R_{HOT} = \frac{V_{T1_HOT_F}}{I_{TS_SOURCE}} = \frac{500mV}{100\mu A} = 5k\Omega$$

2. According to the required battery operation temperature range, for example 0°C to 45°C, look up the NTC thermistor resistor values. For a 10kΩ (B=3435K) NTC thermistor, the resistance values at 0°C is

$$R_{NTC_COLD} = 27.28k\Omega \text{ and the resistance value at } 45^\circ C \text{ is } R_{NTC_HOT} = 4.911k\Omega$$

3. The R_{T1} , R_{T2} can be calculated by the equations:

$$R_{T1}(k\Omega) = \frac{-(R_{NTC_COLD} + R_{NTC_HOT}) + \sqrt{(R_{NTC_COLD} + R_{NTC_HOT})^2 - 4 \times (R_{NTC_COLD} \times R_{NTC_HOT} + \frac{(R_{NTC_COLD} - R_{NTC_HOT}) \times R_{COLD} \times R_{HOT}}{R_{HOT} - R_{COLD}})}}{2} \quad (1)$$

$$R_{T2}(k\Omega) = \frac{R_{NTC_HOT} \times R_{HOT} + R_{T1} \times R_{HOT}}{R_{NTC_HOT} + R_{T1} - R_{HOT}} \quad (2)$$

The resistor network values can be calculated:

$$R_{T1} = 0.180k\Omega, R_{T2} = 279.04k\Omega$$

Select 1% accuracy resistors $R_{T1} = 0\Omega$, $R_{T2} = 280k\Omega$

Thermal Regulation (TREG)

The device monitors the junction temperature T_J to avoid overheating the chip and limit the device surface temperature. When the internal junction temperature exceeds thermal regulation limit T_{REG} , the Boost lowers down the charge current. During thermal regulation, the average charging current is below the programmed battery charging current. In thermal regulation, termination is temporarily disabled.

Thermal Shutdown (TSHUT)

The devices have thermal shutdown built in to turn off the charger when device junction temperature exceeds T_{SHUT} . The charger is re-enabled with soft-start when the junction temperature is 30°C below T_{SHUT} . During thermal shutdown, charge is suspended.

LPS Preliminary Datasheet
LPS Confidential

Application and Implementation

Application Information

The device can be used for a general purpose 4/5/6-cell battery charger. The charge current is programmable by a resistor from ISET pin to GND. The charge voltage is set by VSET pin. R5 and C3 are added to prevent battery hot plug-in overvoltage at BAT pin. The same RC circuit can be added between VIN to VBUS pin if a high input voltage hot-plug is required.

Application Schematic

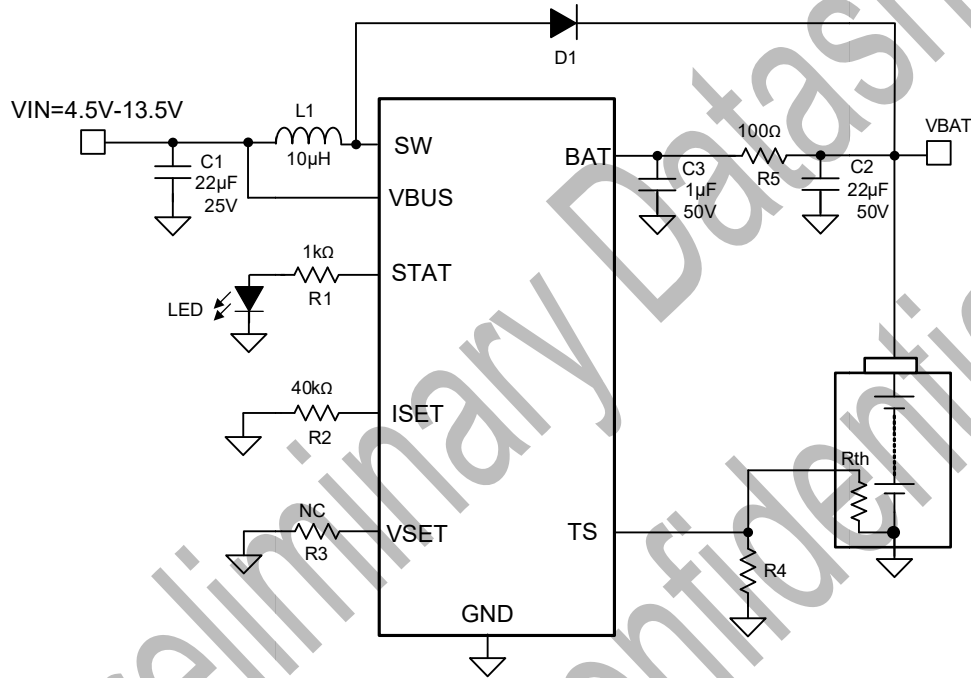

Figure 2: Typical Applications Schematic

Charge Current Setting

The charger current is set by the resistor value at the ISET pin according to the equation below:

$$I_{CHG} (A) = K_{ICHG} (A \cdot k\Omega) / R_{ISET}(k\Omega) \quad (3)$$

K_{ICHG} is current setting gain that is listed in Electrical Characteristics table and R_{ISET} is the resistor value from ISET pin to GND. K_{ICHG} is typically 40 (A·kΩ) and the typical values vs. charge currents are illustrated in Figure xx (TBD) in Typical Characteristics.

Charge Voltage Setting

A resistor connected at VSET pin programs charge voltages per cell. The actual battery charge voltages are $N \cdot V_{BATREG}$ and N is the number of battery cells selected by part numbers.

- $R_{VSET} = 510\Omega$ or short, $V_{BATREG}=4.2V$
- $R_{VSET} = 10k\Omega$, $V_{BATREG}=4.35V$
- $R_{VSET} = 51k\Omega$, $V_{BATREG}=4.3V$
- $R_{VSET} = 200k\Omega$ or open, $V_{BATREG}=4.15V$



Application Curves (TBD)

LPS Preliminary Datasheet
LPS Confidential

PCB Layout Guideline

Appropriate PCB layout is important in the power supply design. Good PCB layout minimizes EMI and noises, allows good output voltage regulation and achieves higher efficiency. The following design considerations are recommended:

- Decouple BAT and VBUS pins to GND on top layer and place decoupling capacitors as close to those pins as possible. Always avoid vias if possible because they have parasitic inductance and resistance. If vias are inevitable, always use more than one vias in parallel to decrease parasitics for power traces.
- The power path from SW pin to the shottky D1 to Boost output capacitor C2 shall has short and wide path.
- Connect GND pad to the ground plane on the bottom side with multiple vias that is for both heat dissipation and electrical connection.
- Minimize switching SW node size and trace lengths and keep it away from ISET and BAT traces.
- An example of a 2-layer PCB layout is shown in Figure 3 as below.

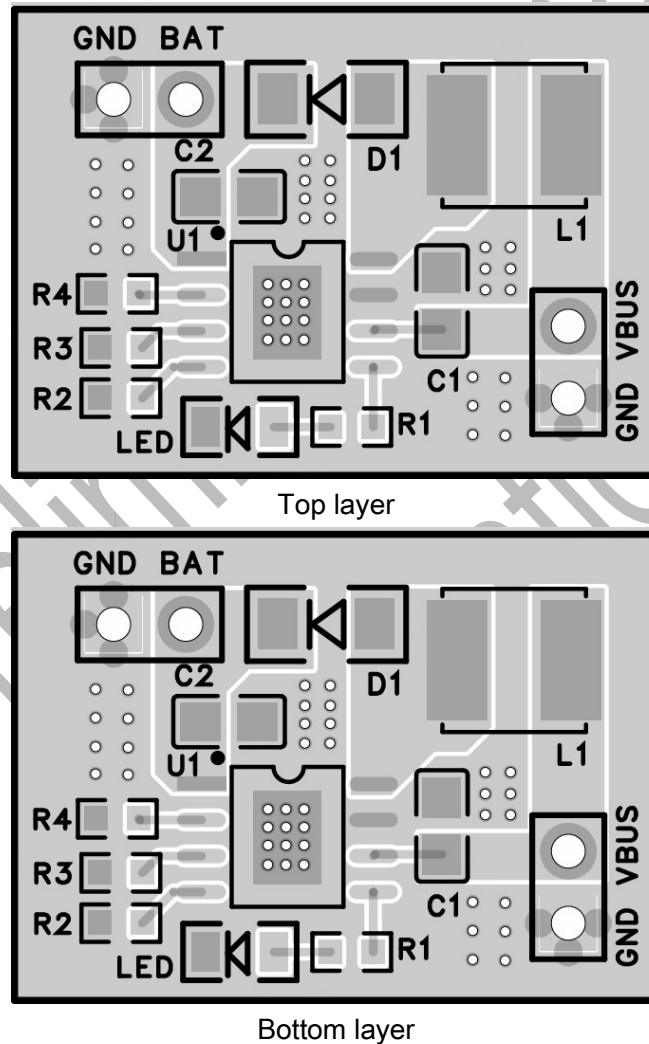
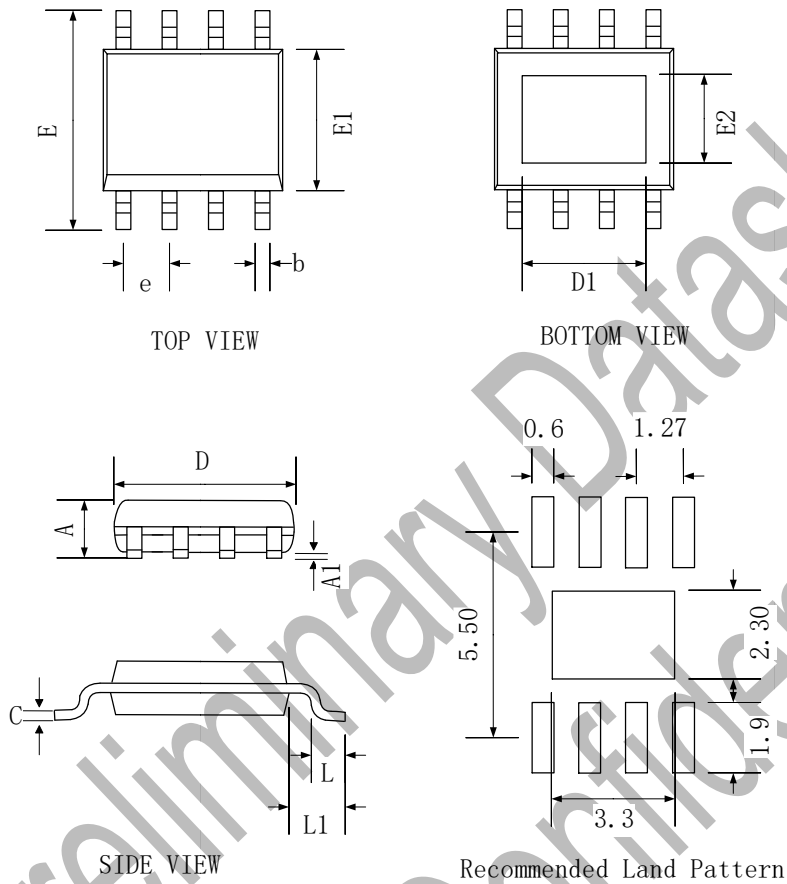

Figure 3. 2-layer PCB layout example

Packaging Information

ESOP-8L



SYMBOL	Dimensions In Millimeters		
	MIN	NOM	MAX
A	1.35	-	1.75
A1	0.00	-	0.15
b	0.30	0.40	0.50
c	0.20 REF		
D	4.70	4.90	5.10
D1	3.2 REF		
E	5.70	6.00	6.30
E1	3.70	3.90	4.10
E2	2.30 REF		
e	1.27 BSC		
L	0.40	0.60	0.80
L1	1.05 REF		



Tape and Reel information-ESOP-8L

REEL DIMENSIONS

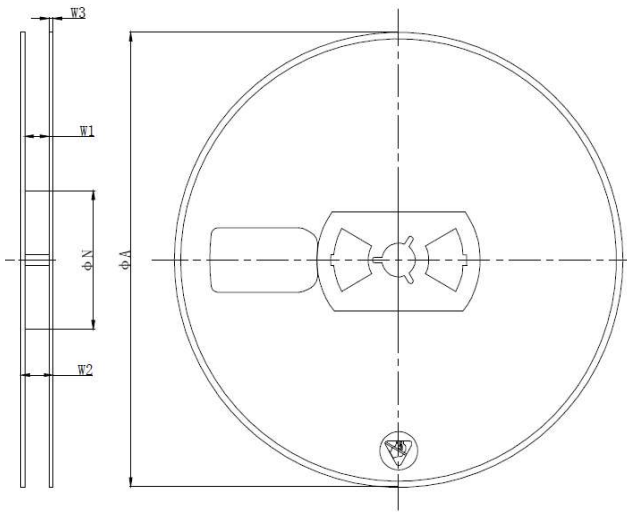

SYMBOL	Dimensions In Millimeters		
	MIN	NOM	MAX
ΦA	325.00	329.00	333.00
W2	15.00	17.00	19.00

TAPE DIMENSIONS

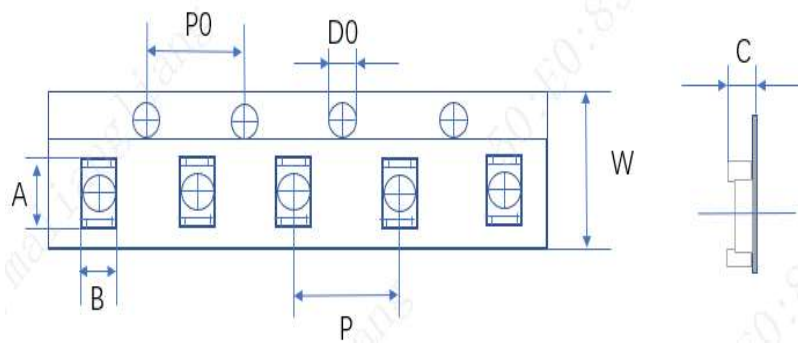

SYMBOL	Dimensions In Millimeters		
	MIN	NOM	MAX
A	6.20	6.60	7.00
B	5.10	5.50	5.90
P0	3.80	4.00	4.20
P	7.80	8.00	8.20
D0	1.30	1.50	1.70
W	11.90	12.00	12.30
C	1.90	2.10	2.30

PIN1 AND TAPE FEEDING DIRECTION

