



Features

- Ultra-low current consumption: 0.7 μ A (Typ)
- Wide input voltage range: 1.5V to 5.5V
- Fixed output voltages:
 - 0.7V to 5.2V with 100mV/step
- High output voltage accuracy: \pm 1.5%
- Low dropout voltage:
 - 60mV (Typ) at 50mA ($V_{OUT} = 3.3V$)
 - 130mV (Typ) at 100mA ($V_{OUT} = 3.3V$)
- Integrated over-current protection
- Support 1.8V logic EN pin
- Robust ESD capability:
 - Human Body Model: 2 kV
 - Charged Device Model: 0.5 kV
- Available in small packages:
 - SOT23
 - TDFN-4

Applications

- Wearable Devices
- Portable Medical Equipment
- PDAs, Mobile Phones GPS devices

Ordering Information

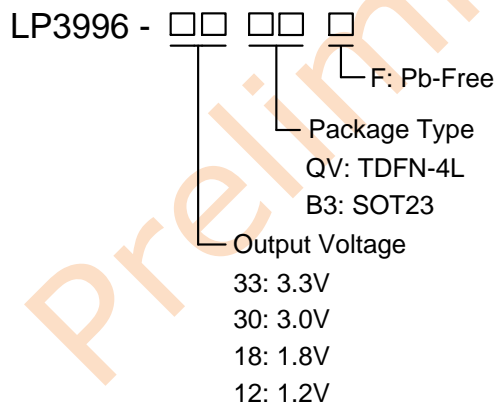

Description

The LP3996 is a low-dropout voltage regulator with low quiescent current and in ultra-small package. The LP3996 can deliver output current up to 250mA. It offers different output voltages without external resistors. For the nominal output voltage, 1.2V, 1.8V, 3.0V and 3.3V will be available.

The LP3996 is integrated over current protection and short circuit protection in order to protect system abnormal.

The output capacitor as small as 0.1 μ F is good enough for LP3996.

The LP3996 is available in 3 pins SOT23 package or 4 pins ultra-small TDFN package with only 1mm \times 1mm size.

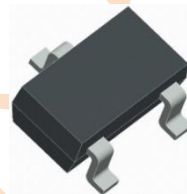

SOT23

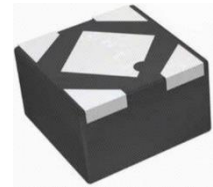

TDFN-4

Marking Information

Device	VOUT	Marking	Package	Shipping
LP3996-33B3F	3.3V	LPS 6JYWX	SOT23	3K/Reel
LP3996-30B3F	3.0V	LPS 6MYWX	SOT23	3K/Reel
LP3996-18B3F	1.8V	LPS 6PYWX	SOT23	3K/Reel
LP3996-12B3F	1.2V	LPS 6QYWX	SOT23	3K/Reel
LP3996-33QVF	3.3V	LWX	TDFN-4	12K/Reel
LP3996-30QVF	3.0V	MWX	TDFN-4	12K/Reel
LP3996-18QVF	1.8V	NWX	TDFN-4	12K/Reel
LP3996-12QVF	1.2V	OWX	TDFN-4	12K/Reel

Marking indication: Y: Production year, W: Production week, X: Production batch



Application Diagram

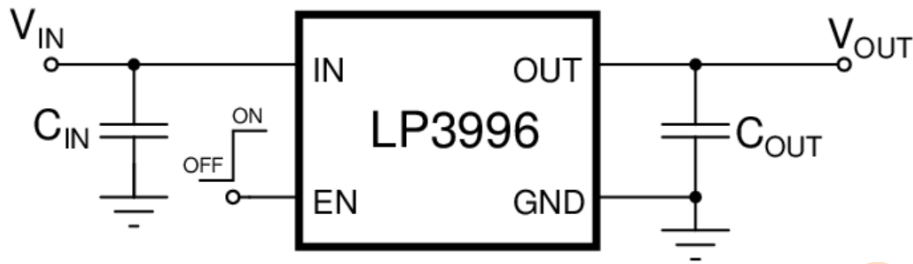
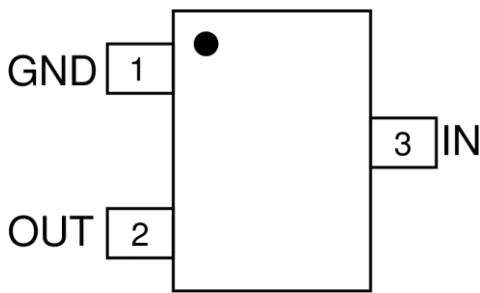
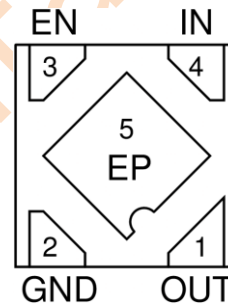

Figure 1 Typical Application Diagram

Pin Configuration



SOT23 (Top View)



TDFN-4 (Bottom View)

Pin Description

Pin No. SOT-3	Name	Description
1	GND	Ground.
2	OUT	Regulated output. A minimum 0.1μF ceramic capacitor is needed from it to ground.
3	IN	Input and power source. A small capacitor is recommended from this pin to ground.
Pin No. TDFN-4		
1	OUT	Regulated output. A minimum 0.1μF ceramic capacitor is needed from it to ground.
2	GND	Ground.
3	EN	Active-high enable pin. 1: enable the device. 0 or floating: disable the device.
4	IN	Input and power source. A small capacitor is recommended from this pin to ground.
5	EP	Exposed Pad for thermal dissipation. Need to be tied to ground.



Functional Block Diagram

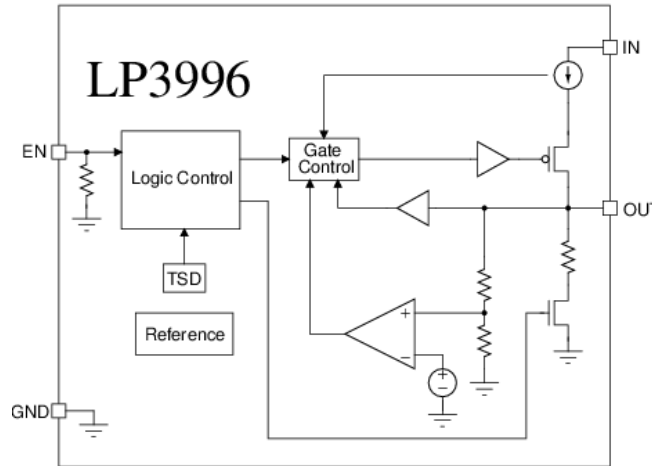

Absolute Maximum Ratings (Note 1)

- IN to GND ----- -0.3V to 6.5V
- OUT to GND ----- -0.3V to ($V_{IN} + 0.3V$) or 6.5V
- EN to GND ----- -0.3V to 6.5V
- Output Current ----- 300mA
- Maximum Junction Temperature (T_J) ----- 150°C
- Storage Temperature (T_{STG}) ----- -55°C to 150°C
- Maximum Soldering Temperature (At leads, 10 sec) ----- 260°C

*Note 1: Stresses beyond those listed under “Absolute Maximum Ratings” may cause permanent damage to the device. These are stress ratings only, and functional operation of the device at these or any other conditions beyond those indicated in the operational sections of the specifications is not implied. Exposure to absolute maximum rating conditions for extended periods may affect device reliability.

Thermal Information

- Maximum Power Dissipation (SOT-3, P_D , $T_A \leq 25^\circ\text{C}$) ----- 420mW
- Thermal Resistance (SOT23-3, θ_{JA}) (Note 2) ----- 240 °C/W
- Maximum Power Dissipation (TDFN-4, P_D , $T_A \leq 25^\circ\text{C}$) ----- 390mW
- Thermal Resistance (TDFN-4, θ_{JA}) (Note 2) ----- 256 °C/W

*Note 2: Measured using 2S2P JEDEC standard PCB with ambient temperature < 25°C

Electro-Static Discharge and Latch-up

- HBM (Human Body Model, JEDEC JS-001) ----- 2000V
- CDM (Charged Device Model, JEDEC JS-002) ----- 500V

Recommended Operating Conditions

- Input and supply voltage on IN ----- 1.5V to 5.5V
- Output DC current ----- Up to 250mA
- Output capacitor ----- > 0.1µF
- Operating ambient temperature ----- -40°C to 85°C



Electrical Characteristics

The parameters are specified under conditions: V_{IN} is equal to the greater value between $V_{OUT(NOM)} + 0.5V$ and $2.0V$, $-40^{\circ}C \leq T_J \leq 85^{\circ}C$, $I_{OUT} = 1mA$, $C_{IN} = C_{OUT} = 1\mu F$, unless otherwise noted. Typical values are at $T_J = 25^{\circ}C$.

Parameter	Symbol	Test Conditions	Min	Typ.	Max	Units
Output voltage accuracy		$V_{OUT(NOM)} \leq 1.5V$, $T_J = 25^{\circ}C$	-2		2	%
Output voltage accuracy over temperature		$V_{OUT(NOM)} \leq 1.5V$ $-40^{\circ}C \leq T_J \leq 85^{\circ}C$	-3		3	%
Input quiescent current	I_Q	$V_{IN} = 1.5V$ to $5.5V$, $V_{EN} = V_{IN}$, no load		0.8		μA
Input shutdown current	I_{SHDN}	$V_{IN} = 1.5V$ to $5.5V$, $V_{EN} = 0V$, no load		0.1		μA
Line regulation	$\frac{\Delta V_{OUT}}{\Delta V_{IN} \times V_{OUT}}$	$I_{OUT} = 20mA$, $V_{IN} = (V_{OUT(NOM)} + 1V)$ to $6V$		0.02	0.05	%/V
Load regulation	ΔV_{LOAD}	$I_{OUT} = 1mA$ to $100mA$, $V_{IN} = V_{OUT(NOM)} + 1.5V$, $-40^{\circ}C \leq T_J \leq 85^{\circ}C$		15	40	mV
Dropout voltage ⁽³⁾	V_{DROP}	$V_{OUT(NOM)} = 1.2V$, $I_{OUT} = 10mA$, $T_A = 25^{\circ}C$		0.12	0.25	V
		$V_{OUT(NOM)} = 1.8V$, $I_{OUT} = 100mA$, $T_A = 25^{\circ}C$		0.35	0.7	
		$V_{OUT(NOM)} = 3.0V$, $I_{OUT} = 100mA$, $T_A = 25^{\circ}C$		0.19	0.36	
		$V_{OUT(NOM)} = 3.3V$, $I_{OUT} = 100mA$, $T_A = 25^{\circ}C$		0.17	0.33	
Output current limit	I_{LIM}	$V_{OUT(NOM)} < 1.5V$, $V_{IN} = V_{OUT(NOM)} + 1.5V$, $V_{OUT} = 0.9 \times V_{OUT(NOM)}$		300		mA
		$V_{OUT(NOM)} \geq 1.5V$, $V_{IN} = V_{OUT(NOM)} + 1.0V$, $V_{OUT} = 0.9 \times V_{OUT(NOM)}$		300		
Short circuit protection	I_{SHORT}	$V_{IN} = V_{OUT(NOM)} + 1.0V$, $V_{OUT} = 0V$		50		mA
Output voltage noise	V_{NOISE}	$BW = 10Hz$ to $100kHz$, $I_{OUT} = 30mA$		330		μV_{RMS}
Power supply rejection ratio	PSRR	$V_{IN} = V_{OUT(NOM)} + 1.5V$, $I_{OUT} = 30mA$, $f = 1kHz$, $\Delta V_{RIPPLE} = 0.2 \times V_{PP}$		24		dB
EN logic high voltage level	V_{IH}		1.1			V
EN logic low voltage level	V_{IL}				0.3	V
EN pin leakage current	I_{EN}			30		nA
EN pull-up current	I_{EN_UP}			40		nA
Output discharge resistance	R_{DIS}	$V_{EN} = 0V$		1		k Ω

*Note 3: Dropout voltage is measured under condition $V_{IN} = V_{OUT(NOM)} - 0.1V$.



Typical Waveforms and Characteristics

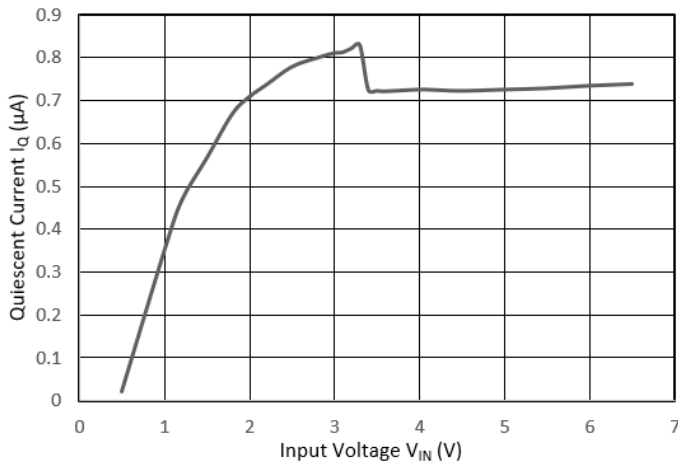

Figure 4. Quiescent Current vs Input Voltage
($C_{IN}=C_{OUT}=1\mu F$, $V_{EN}=V_{IN}$, no load)

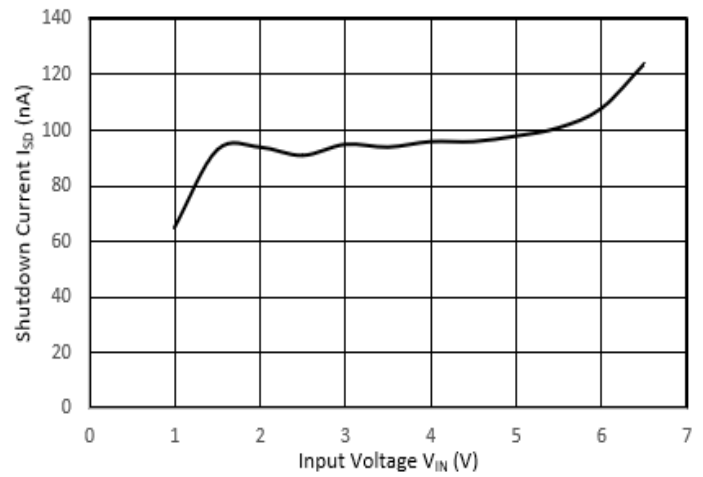

Figure 5. Shutdown Current vs Input Voltage
($C_{IN}=C_{OUT}=1\mu F$, $V_{EN}=0V$, no load)

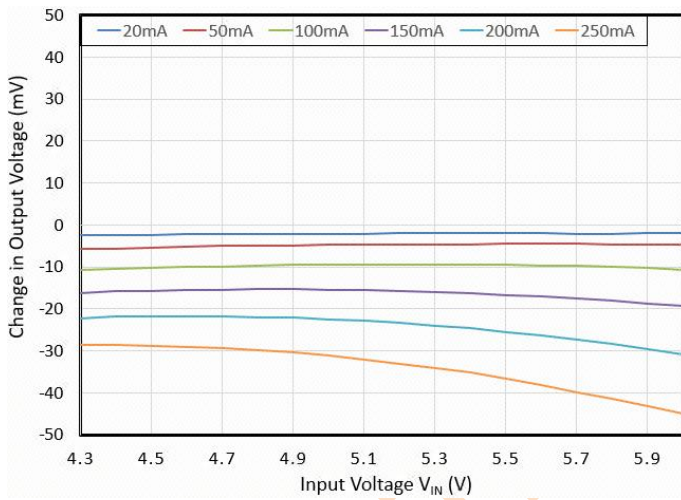

Figure 6. Line Regulation vs Output Current
($V_{OUT(NOM)} = 3.3V$)

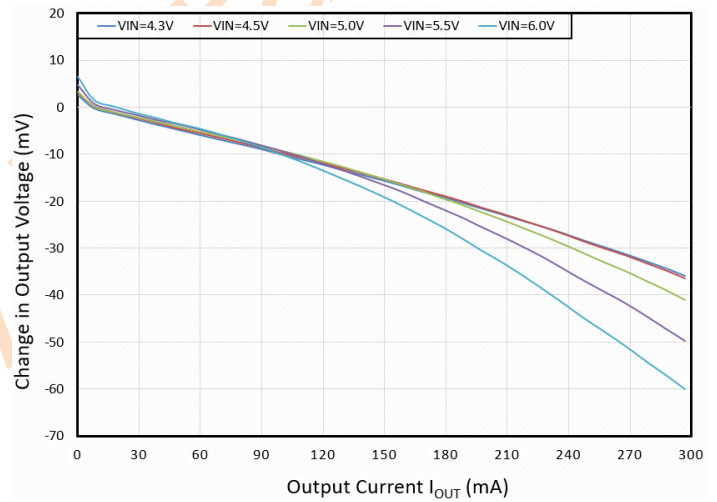

Figure 7. Load Regulation vs Input Voltage
($V_{OUT(NOM)} = 3.3V$)



Function Description

Overview

The LP3996 is a Low dropout voltage regulator with ultra-low current consumption. It has fixed output voltage with good transient performance. The product is available in ultra-small package 1mm x 1mm TDFN-4.

Selectable output voltage

The product will output fixed voltage as long as the input voltage is higher than $V_{OUT(NOM)} + V_{DROP}$. $V_{OUT(NOM)}$, the output voltage, can be selected from 0.7V to 5.2V (100mV/step) and can source up to 200mA loading current.

Enable function

The EN pin is an active high Logic input pin that is compatible with 1.2V control logic. The internal power element is turned off when EN pin is tied low.

When the EN pin is pulled high, the LP3996 will be activated and output voltage according to setting.

Auto discharge

The LP3996 has a quick discharge function. When the device is disabled by pulled down EN pin, a discharge resistor is connected between OUT and GND. The resistance is 1k Ω (typical).

Over current protection

The device features a current limit function when the over current event is detected to reach 300mA (Typ) and output voltage will drop accordingly. In the heavy load condition, the current limit value will be reduced along with output voltage drops. If the output is shorted to ground, the current limit value will foldback to smaller, 50mA, as in the *Electrical Characteristics Table*.

Application Information

Capacitor consideration

External capacitors on IN and OUT are recommended in application, 0.1 μ F for C_{OUT} and 1 μ F for C_{IN} at least. Closer placement of the capacitors to the device, both IN and OUT, would be better for stability.

Power Dissipation

The internal power dissipation from the power MOSFET, when it is turned on, is the main source of junction temperature rising. In this case, the power dissipation and the junction temperature in conducting mode can be calculated as following:

$$P_D = (V_{IN} - V_{OUT}) \times I_{OUT}$$

P_D : Power Dissipation (W)

V_{IN} : Input voltage (V)

V_{OUT} : Output voltage (V)

I_{OUT} : Output current (A)

$$T_J = P_D \times \theta_{JA} + T_A$$

T_J : Junction temperature ($^{\circ}$ C)

θ_{JA} : Package thermal resistance ($^{\circ}$ C /W) (Note 4)

T_A : Ambient temperature ($^{\circ}$ C)

***Note 4: The calculation base on thermal resistance is only valid in Lab condition. The value of θ_{JA} could change in customer PCB environment.**



Package Dimensions

SOT23

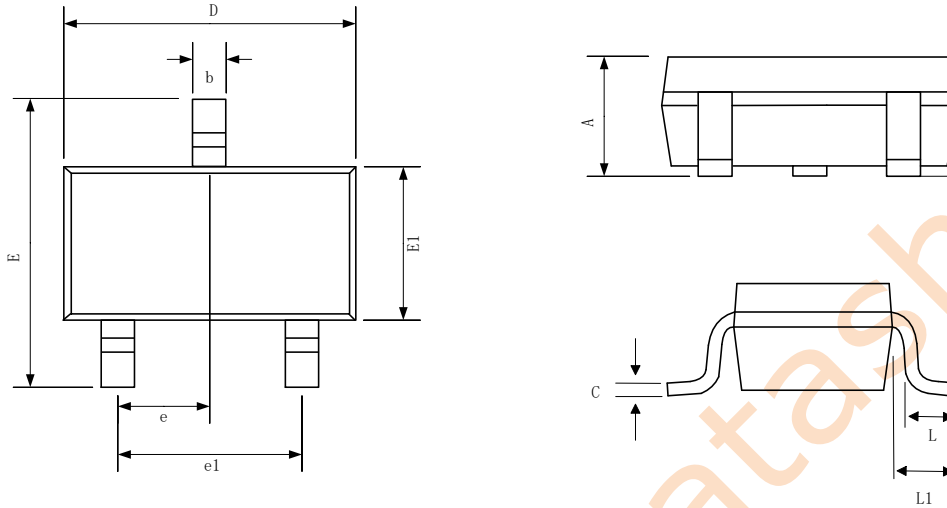

SYMBOL	MILLIMETER		
	MIN	NOM	MAX
A	0.900		1.200
A1	0.000	0.050	0.100
b	0.300	0.400	0.500
c	0.008	0.120	0.150
D	2.800	2.900	3.000
E	2.250	2.400	2.550
E1	1.200	1.300	1.400
e	0.950BSC		
e1	1.900BSC		
L	0.200	0.350	0.500
L1	0.550REF		



TDFN-4

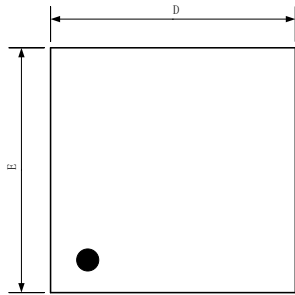

TOP VIEW

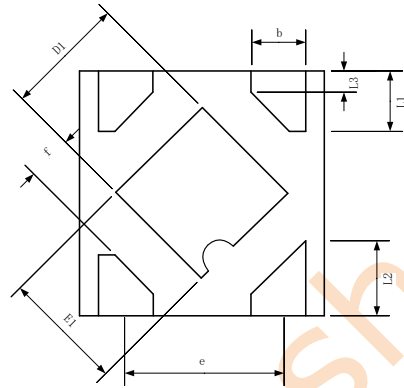

BOTTOM VIEW

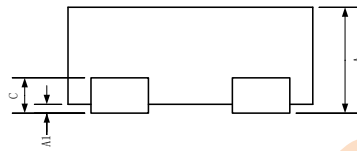

SIDE VIEW

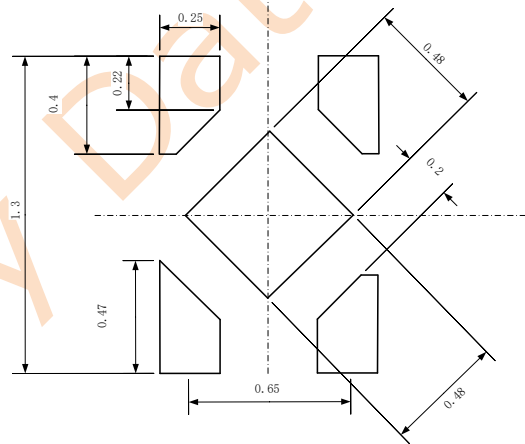

Recommended Land Pattern

SYMBOL	MILLIMETER		
	MIN	NOM	MAX
A	0.35	-	0.40
A1	0.00	0.02	0.05
b	0.20	0.25	0.30
c	0.07	0.12	0.17
D	0.95	1.00	1.05
D1	0.43	0.48	0.55
E	0.95	1.00	1.05
E1	0.43	0.48	0.55
e	0.65BSC		
L1	0.2	0.25	0.30
L2	0.27	0.32	0.37
L3	0.09REF		
f	0.18REF		