



Features

- Easy-to-use standalone single-cell charger
- High input voltage linear charger
 - Support up to 6.3V operating input voltage with 28V absolute maximum input rating
 - Maximum BAT withstand voltage up to 14V
 - Programmable up to 1200mA fast charge current
 - ±0.5% regulated output voltage accuracy
 - Trickle current 10% of fast charge current
 - Termination current 10% of fast charge current
- High integration
 - Integrated reverse blocking MOSFET
 - Built-in charge current sensing
 - Internal loop compensation
 - Integrated charge status indication
- Support full charge cycle of trickle current mode, constant current (CC) mode, constant voltage (CV) mode, charge termination and automatic recharge
- BAT leakage current <30nA typical
- Protection features
 - Input under-voltage lockout (UVLO)
 - Input over-voltage protection (OVP)
 - Battery reverse connection protection
 - Thermal regulation
- RoHS Compliant and 100% Lead (Pb)-Free
- Package: DFN3x3mm-8

Applications

- Wireless Speaker
- Cordless Power Tools
- Gaming Devices
- Portable Media Players
- Handheld Battery-Powered Devices
- E-Cigarettes
- Power Bank

General Description

The LP4072A is a highly advanced linear charger for single cell Li-Ion and Li-Polymer batteries. The device is ideally suited for portable applications due to the small DFN3x3mm-8 package and low number of external components required.

The device employs a full charge algorithm with trickle current, constant current (CC), constant voltage (CV) modes, charge termination and automatic recharge. The device supports charge current up to 1200mA, programmed by an external resistor. The device can withstand an input voltage up to 28V, which can protect the charger from the accidental insertion of a high voltage supply or a hot insertion. The device can withstand a BAT voltage up to 14V, which is suited for power battery applications. Without an input supply, the battery leakage current is less than 30nA typical.

The device provides various safety features for battery charging, including input under voltage lockout (UVLO), input over-voltage protection (OVP), battery reverse connection protection, and thermal regulation protection that is implemented by reducing the charge current when the junction temperature reaches 140°C.

The LP4072A is available in a DFN3x3mm-8 package.

Order Information

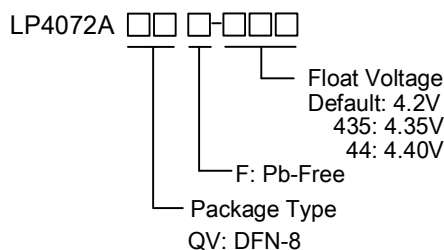



Device Information

Part Number	Top Marking	Battery Voltage	Moisture Sensitivity Level	Package	Shipping
LP4072AQVF	LPS LP4072 AYWX	4.20V	MSL3	DFN3x3mm-8	4K/REEL
LP4072AQVF-435	LPS BtYWX	4.35V	MSL3	DFN3x3mm-8	4K/REEL
LP4072AQVF-44	LPS BuYWX	4.40V	MSL3	DFN3x3mm-8	4K/REEL

Marking indication:

Y: Production year. W: Production week. X: Series number.

Typical Application Circuit

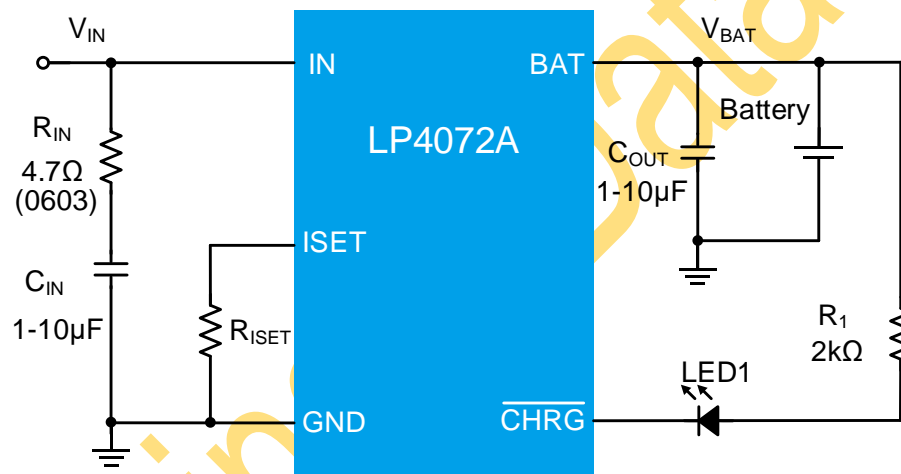



Pin Diagram

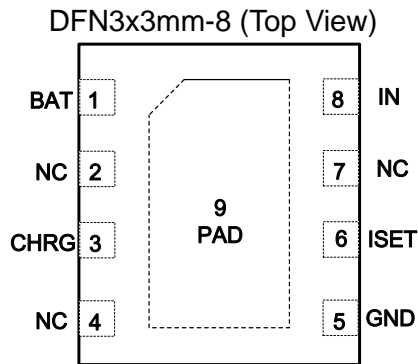

Pin Description

Pin	Name	Description
1	BAT	Battery Pin. Connect to the battery, A 1-10 μ F capacitor is needed typically.
3	CHRG	Open-Drain Charge Status Output. When the device is in charging state, the CHRG pin is pulled low by an internal NMOS. When the charge cycle is completed, the internal NMOS turned-off, the pin could be pulled high by an external pull-up resistor.
5	GND	GND. Connect to the system ground.
6	ISET	Fast Charge Current Program Pin. Connect this pin with an external resistor R_{ISET} to GND to program the fast charge current.
8	IN	Positive Supply Voltage Input. Place a 4.7 Ω resistor and a 1-10 μ F ceramic capacitor in series from IN to GND and place the components as close as possible to IC.
2, 4, 7	NC	No connection.



Absolute Maximum Ratings ⁽¹⁾

IN to GND	-----	-0.3V to 28V
BAT to GND	-----	-5V to 14V
ISET, CHRГ to GND	-----	-0.3V to 6.5V
Maximum Junction Temperature (T _J)	-----	150°C
Storage Temperature	-----	-55°C to 150°C
Maximum Soldering Temperature (at leads, 10 sec)	-----	260°C

Note: (1) Stresses beyond those listed under “Absolute Maximum Ratings” may cause permanent damage to the device. These are stress ratings only, and functional operation of the device at these or any other conditions beyond those indicated in the operational sections of the specifications is not implied. Exposure to absolute maximum rating conditions for extended periods may affect device reliability.

ESD Susceptibility

HBM (Human Body Model)	-----	2kV
MM (Machine Model)	-----	200V

Recommended Operating Conditions

Input Voltage	-----	4.5V to 6V
Maximum Charge Current	-----	1200mA
Operating Junction Temperature Range (T _J)	-----	-40°C to 150°C
Operating Ambient Temperature Range (T _A)	-----	-40°C to 85°C



Electrical Characteristics

(The specifications are at $T_A=25^{\circ}\text{C}$, $V_{IN} = 5\text{V}$, unless otherwise noted.)

Symbol	Parameter	Condition	Min	Typ	Max	Units
INPUT VOLTAGE AND CURRENT						
V_{IN}	Input Voltage Range		4.5	5	6	V
I_{SB}	Input Standby Current	Standby mode (Charge terminated)		90		μA
V_{UVLO}	Input Under Voltage Lockout	V_{IN} Rising	3.75	3.9	4.05	V
V_{UVLO_HYS}	V_{UVLO} Hysteresis	V_{IN} Falling		200		mV
V_{OVP}	Over-Voltage Protection Threshold Voltage	V_{IN} Rising	6.15	6.3	6.45	V
V_{OVP_HYS}	OVP Hysteresis	V_{IN} Falling		150		mV
BAT LEAKAGE CURRENT						
I_{BAT_LKG}	Battery Leakage Current	V_{IN} floating, $V_{BAT}=4.2\text{V}$		0	0.03	μA
BATTERY CHARGER						
V_{FLOAT}	Regulated Output Voltage		4.179	4.2	4.221	V
I_{CC}	Fast Charge Current	$R_{ISET}=3.4\text{k}\Omega$, Constant Current Mode	450	500	550	mA
		$R_{ISET}=17\text{k}\Omega$, Constant Current Mode	90	100	110	mA
I_{TERM}	Termination Current Threshold	$R_{ISET}=3.4\text{k}\Omega$, Constant Voltage Mode		10%		I_{CC}
I_{TRIKL}	Trickle Charge Current	$V_{BAT}<V_{TRIKL}$, $R_{ISET}=3.4\text{k}\Omega$		10%		I_{CC}
V_{TRIKL}	Trickle Charge Threshold Voltage	V_{BAT} Rising	2.75	2.9	3.05	V
V_{TRIKL_HYS}	Trickle Charge Hysteresis Voltage	V_{BAT} Falling		200		mV
ΔV_{RECHRG}	Battery Recharge Voltage Difference Threshold	V_{BAT} Falling	100	150	200	mV
V_{HR}	$V_{IN}-V_{BAT}$ Headroom Threshold Voltage	$V_{BAT}=3.7\text{V}$, V_{IN} Rising	100	130	160	mV
V_{HR_HYS}	V_{HR} Hysteresis	$V_{BAT}=3.7\text{V}$, V_{IN} Falling		80		mV
T_{J_LIMIT}	Junction Temperature Limit	Thermal Foldback Protection State		140		$^{\circ}\text{C}$
R_{ON}	IN-BAT MOSFET On-Resistance	Charge Current=500mA		1000		$\text{m}\Omega$



ISET/CHRG PINs						
V _{ISET_CC}	ISET Pin Voltage	Constant Current Mode		1		V
V _{ISET_TR}		Trickle Current Mode		0.1		V
V _{CHRG_L}	CHRG Pin Output Low Voltage	I _{CHRG_SINK} =5mA			0.5	V
I _{CHRG_SINK}	CHRG Pin Sink Current				5	mA



Typical Characteristics

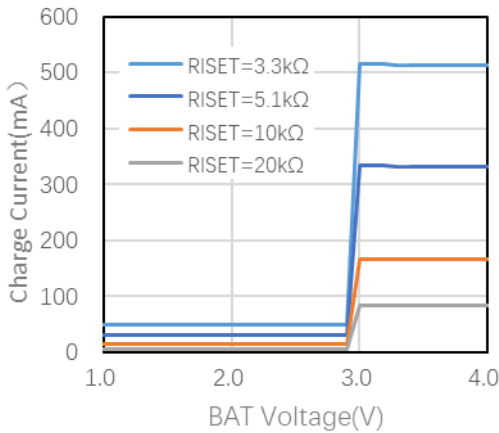

Figure 1. Charge Current vs BAT Voltage
 $V_{IN}=5V$, $25^{\circ}C$

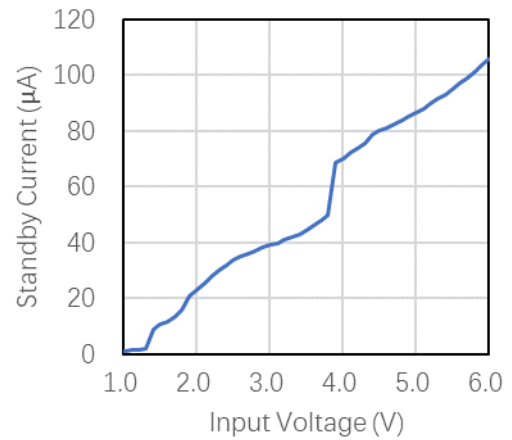

Figure 2. Input Standby current vs Input Voltage
Charge terminated, $25^{\circ}C$

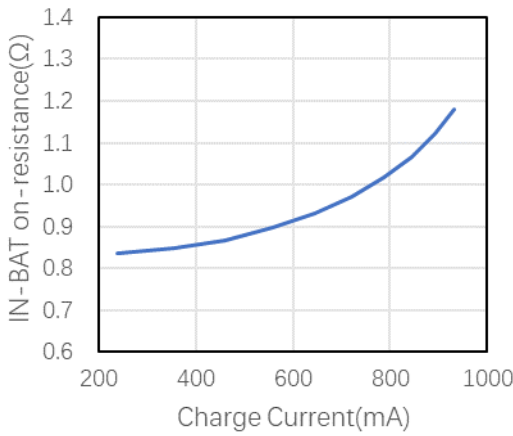

Figure 3. VIN-BAT ON-Resistance vs Charge Current
 $V_{BAT}=3.7V$, $25^{\circ}C$

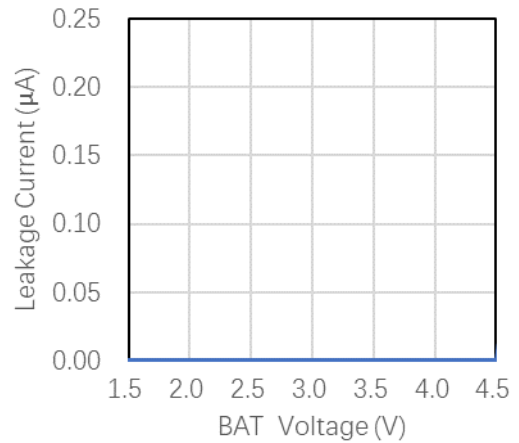

Figure 4. BAT Leakage Current vs V_{BAT}
 $V_{IN}=Floating$, $25^{\circ}C$

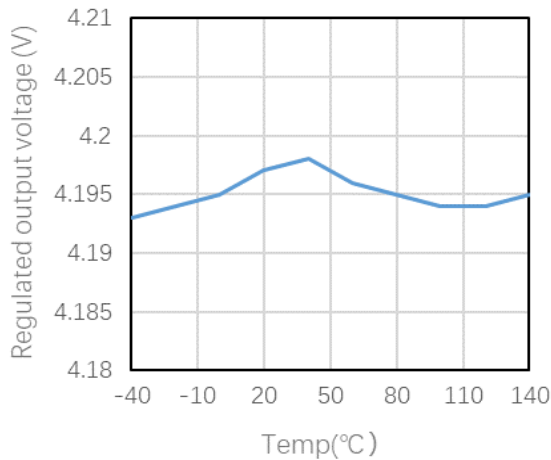
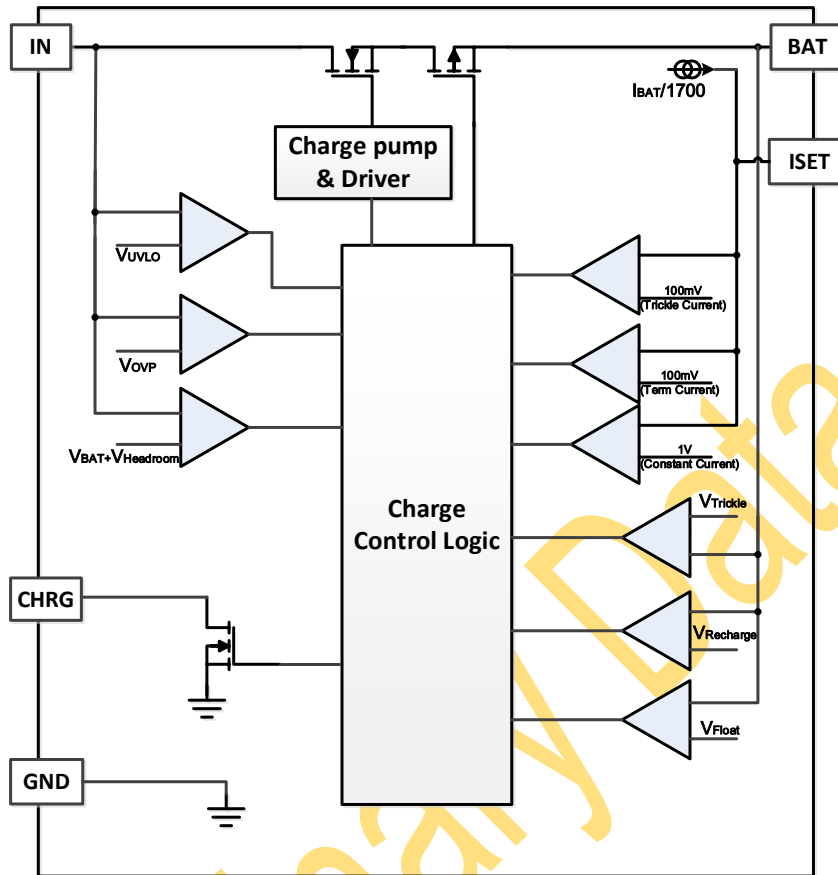

Figure 5. Regulated Output Voltage (V_{FLOAT}) vs Ambient Temperature



Functional Block Diagram





Detailed Description

Overview

The LP4072A is a highly advanced linear charger with up to 1200mA maximum charge current for single cell Li-Ion and Li-Polymer batteries. The device charges the battery with full charge cycle: trickle current mode, constant current mode (CC), constant voltage mode (CV), charge termination and recharge. The typical charge profile can be showed as the figure below.

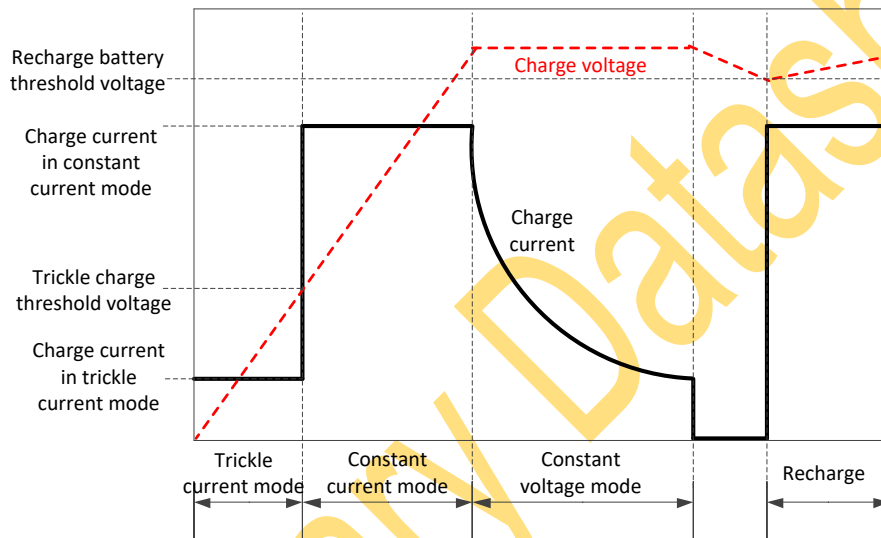

When the battery voltage is lower than Trickle Charge Threshold Voltage (V_{TRIKL} , 2.9V typical), the device charges in the trickle current mode, the charge current will be set to Trickle Charge Current (I_{TRIKL}), which is approximately 10% of the ISET programmed Fast Charge Current (I_{CC}) to bring the battery voltage up to a safe level for full current charging. When the battery voltage rises to V_{TRIKL} , the device enters the constant current mode, where the charge current is $100\%I_{CC}$. When the battery voltage approaches the Regulated Output Voltage (V_{FLOAT}), the device goes to constant voltage mode, the charge current starts to decrease. When the charge current is lower than the Termination Current threshold (I_{TERM}), which is $10\%I_{CC}$, the device will terminate the charging.

The device will automatically recharge the battery while the battery voltage drops ΔV_{RECHRG} (150mV, typical) from the Regulated Output Voltage (V_{FLOAT}).

ISET Programming Fast Charge Current

The Fast Charge Current (I_{CC}) is set by a resistor (R_{ISET}) connecting from the ISET pin to GND. The relationship between I_{CC} and the programming resistance is established by the following formula:

$$I_{CC} = \frac{V_{ISET} \times 1700}{R_{ISET}}$$

where $V_{ISET}=1V$ typical.

Charge Termination and Automatic Recharge

A charge cycle will be terminated when the charge current falls to I_{TERM} ($10\%I_{CC}$, typical), as the battery voltage reached V_{FLOAT} . The function is implemented by monitoring the ISET pin voltage and comparing to a 100mV threshold voltage. When the ISET pin voltage falls below 100mV for longer than 1ms typically, the charging will be



terminated.

Once the charge cycle is terminated, the LP4072A continuously monitors the voltage on the BAT pin by a comparator. A new charge cycle starts when the battery voltage drops by a voltage difference ΔV_{RECHRG} (150mV, typical) from V_{FLOAT} , which means the battery level drops to approximately 80% to 90% capacity. This ensures that the battery always keeps at or near a fully charged condition.

Undervoltage Lockout (UVLO) and Minimum Headroom Voltage

An internal UVLO circuit monitors the input voltage and keeps the device in Shutdown mode until the input supply rises above the UVLO threshold. The UVLO circuitry has a built-in hysteresis of 200 mV. The UVLO circuit always be active.

In addition, the input supply must be V_{HR} (130mV, typical) higher than the battery voltage before the LP4072A become operational. Whenever the input supply is below the UVLO threshold or lower than a voltage of V_{HR} above the VBAT pin, the LP4072A is in Shutdown mode.

Charge Status Indicator (CHRG)

When the input voltage is above the V_{UVLO} and above the voltage of $V_{BAT}+V_{HR}$, but lower than V_{OVP} ($V_{IN}<V_{OVP}$), CHRG pin has two different states: strong pull-down (~5mA) and high impedance. The strong pull-down state implemented by an internal NMOS indicates that the LP4072A is in a charge cycle. After the charge current decreased to I_{TERM} in CV mode and then charging terminated, the CHRG pin will become high impedance.

Function	CHRG
Charging	Low
Charge Terminated	Hi-Z

Thermal Regulation Foldback

An internal thermal regulation foldback loop reduces charge current if the junction temperature reaches a preset value of approximately 140°C to prevent further temperature rise. This function protects the device from excessive temperature and allows the user to get the limits of the power handling capability of a given circuit board without the risk of damaging the device. The charge current can be set according to typical ambient temperature with the assurance that the charger will automatically reduce the current in worst-case conditions.

Charge termination function will not be active when thermal foldback regulation protection is happening.



Application Information

Thermal Consideration

Due to low efficiency of linear charging, the most important factor is thermal design, which is a direct function of input voltage, output charge current and thermal impedance between the battery charger and the ambient cooling air.

The power dissipation can be calculated approximately:

$$P_D = (V_{IN} - V_{BAT}) \times I_{BAT}$$

where P_D is the power dissipation, V_{IN} is the input supply voltage, V_{BAT} is the battery voltage and I_{BAT} is the charge current.

The worst-case situation is when the device has transitioned from the trickle current mode to the constant current mode. In this situation, the battery charger has to dissipate the maximum power.

In this case, with a 5V input voltage source, 1200mA fast charge current, the max power dissipation could be:

$$P_{Dmax} = (5V - 2.9V) \times 1.2A = 2.52W$$

This power dissipation with the battery charger in the DFN3x3mm-8 package may cause thermal regulation foldback to reduce the charge current. Then a trade-off must be made between the charge current and thermal requirements of the charger.

External Capacitors

In order to maintain good stability in the whole charge cycle, a capacitance of 1-10 μ F is recommended to bypass the BAT pin to GND. In addition, the battery and interconnections appear inductive at high frequencies. These elements are in the control feedback loop during constant voltage mode. Therefore, the bypass capacitance may be necessary to compensate for the inductive nature of the battery pack.

Controlling Charging Current by External Signal

If the application needs to control the charging current by an external signal, eg. a MCU GPIO or OD port, the below circuit can be added in the application circuit.

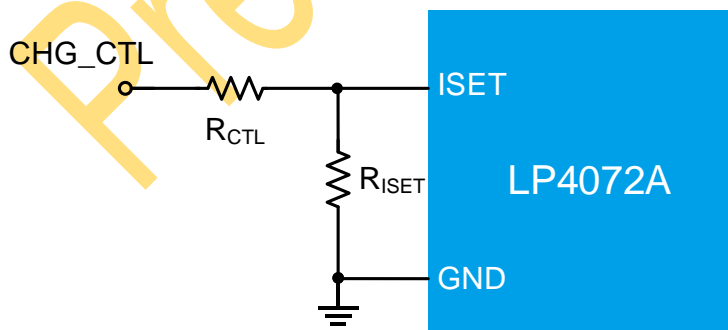

The relationship of the charging current (I_{CC}) and CHG_CTL voltage level (V_{CTL}) in CC mode shows as below table:



CHG_CTL status	ISET Voltage	Charging Current
High level	$V_{ISET} > 1V$	$I_{CC} = 0$
Short to GND	$V_{ISET} = 1V$	$I_{CC} = \frac{1V}{R_{ISET} // R_{CTL}}$
Hi-Z	$V_{ISET} = 1V$	$I_{CC} = \frac{1V}{R_{ISET}}$

Layout Consideration

For optimum voltage regulation, place the battery pack as close as possible to the device's BAT and GND pins. This is recommended to minimize voltage drops along the high current-carrying PCB traces. If the PCB layout is used as a heat sink, adding many vias in the heat sink pad can help conduct more heat to the PCB backplane, thus reducing the maximum junction temperature. It is also recommended to place the capacitor C_{IN} and C_{OUT} as close as possible to the corresponding pins and the GND pin.



Packaging Information

DFN3x3mm-8

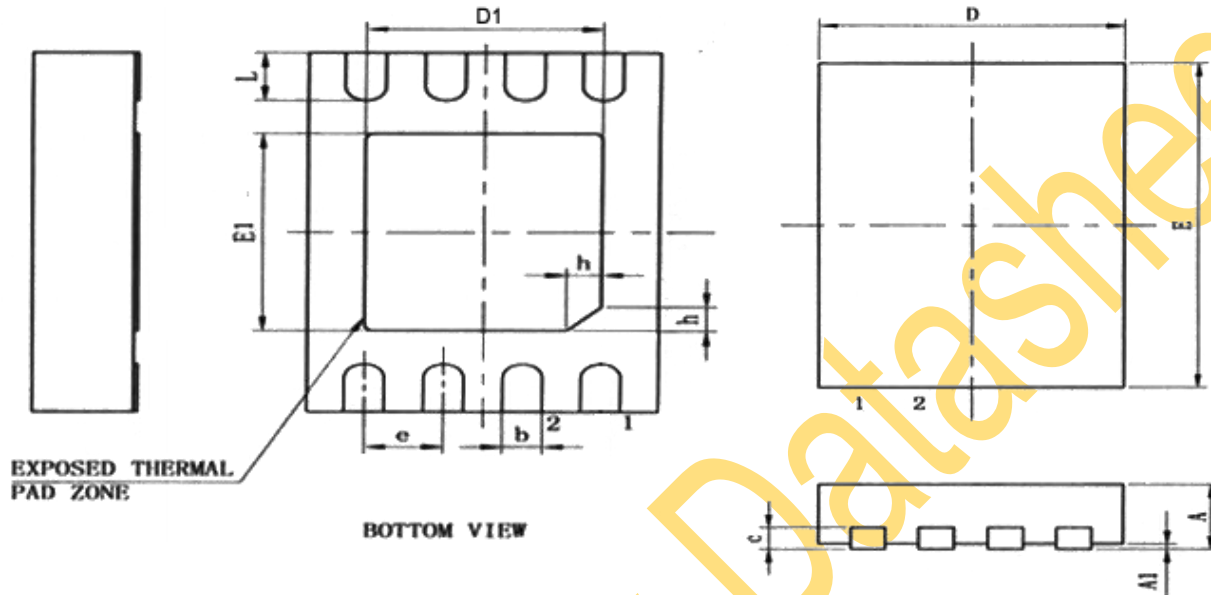

SYMBOL	MILLIMETER		
	MIN	NOM	MAX
A	0.70	0.75	0.80
A1	—	0.02	0.05
b	0.26	0.28	0.31
c	0.19	0.20	0.23
D	2.90	3.00	3.10
D1	2.25	2.30	2.35
e	0.65BSC		
E	2.90	3.00	3.10
E1	1.45	1.50	1.60
L	0.25	0.30	0.35
h	0.20	0.25	0.30



Tape and Reel Information

REEL DIMENSIONS

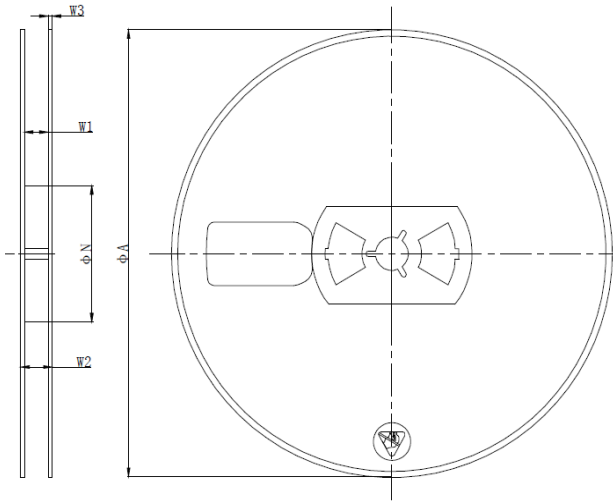

SYMBOL	Dimensions In Millimeters		
	MIN	NOM	MAX
ΦA	327.00	329.00	331.00
W2	14.40	16.40	18.40

TAPE DIMENSIONS

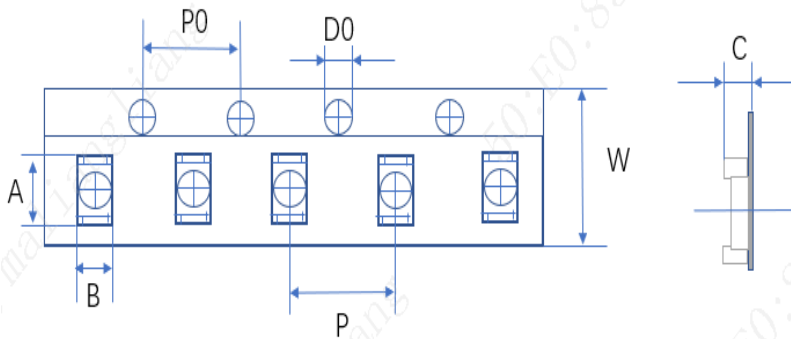

SYMBOL	Dimensions In Millimeters		
	MIN	NOM	MAX
A	3.10	3.40	3.70
B	3.10	3.40	3.70
P0	3.90	4.00	4.10
P	7.90	8.00	8.10
D0	1.45	1.55	1.65
W	12.70	12.00	12.30
C	0.95	1.10	1.25

PIN1 AND TAPE FEEDING DIRECTION

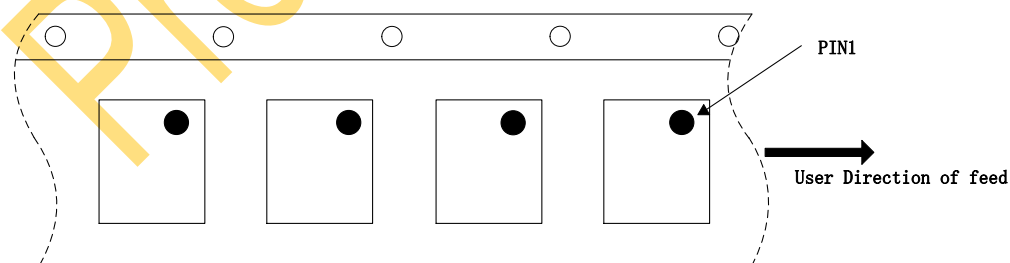



Classification of IR Reflow Profile

Profile Feature	Sn-Pb Eutectic Assembly	Pb-Free Assembly
Preheat/Soak		
Temperature Min(T_{SMIN})	100°C	150°C
Temperature Max(T_{SMAX})	150°C	200°C
Time(T_s) from (T_{SMIN} to T_{SMAX})	60~120 seconds	60~120 seconds
Ramp-up rate (T_L to T_P)	3°C/second max	3°C/second max
Liquidous temperature(T_L)	183°C	217°C
Time(t_L) maintained above T_L	60~150 seconds	60~150 seconds
Peak package body temperature (T_P)	For users T_P must not exceed the Classification temp in Table 1. For suppliers T_P must equal or exceed the Classification temp in Table 1.	For users T_P must not exceed the Classification temp in Table 2. For suppliers T_P must equal or exceed the Classification temp in Table 2.
Time(t_P)* within 5°C of the specified classification temperature(T_C), see Figure1	20* seconds	30* seconds
Ramp-down rate (T_P to T_L)	6°C/second max	6°C/second max
Time 25°C to peak temperature	6 minutes max	8minutes max
* Tolerance for peak profile temperature (T_P) is defined as a supplier minimum and a user maximum.		

Table 1 Sn-Pb Eutectic Process - Classification Temperatures (T_C)

Package Thickness	Volume mm ³ <350	Volume mm ³ ≥350
<2.5mm	235°C	220°C
≥2.5mm	220°C	220°C

Table 2 Pb-Free Process - Classification Temperatures (T_C)

Package Thickness	Volume mm ³ <350	Volume mm ³ 350~2000	Volume mm ³ ≥350
<1.6mm	260°C	260°C	260°C
1.6mm~2.5mm	260°C	250°C	245°C
>2.5mm	250°C	245°C	245°C

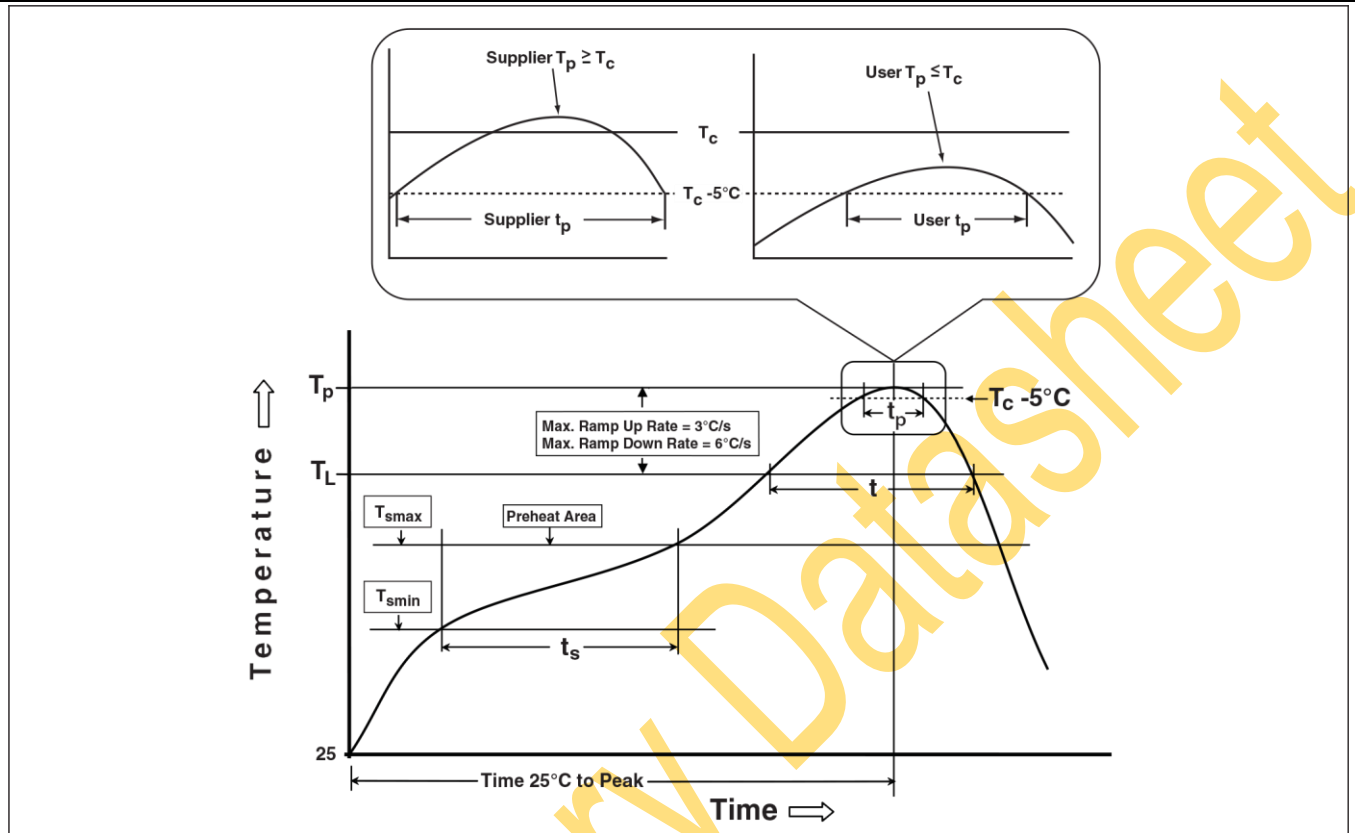

Figure1 Classification Profile (Not to scale)

Products conform to “JEDEC J-STD-020C” standards;

Products shipped conform to “Rohs” standards;

Moisture Sensitivity Level: MSL3 (CONDITION: $\leq 30\text{ }^{\circ}\text{C}/60\%\text{RH}$ 、Time control:168 hours) ;