

### Features

- Input Supply Range: 2.5V ~ 5.5V
- 14-Channel Level Shifter
  - +40V Highest Voltage Level
  - 20V Lowest Negative Voltage level
  - Maximum 700ns Rising/Falling Time
- Level Shifter input logic
  - 2 STO input/output
  - Suitable for 4/6/8 Phase Applications
  - Support 1 clock input or 2 clock input
  - 1 clock input 1/2 line turn on function
  - 1 clock input 0/1/2/3line pre-charge
  - 2 clock input 1/2 line turn on function
- Protection Function
  - Input under voltage lockout (UVLO)
  - Thermal overload protection (OTP)
  - Over Current Protection (OCP)
  - CKI input stop protection (CISP)
  - Short Circuit Protection (SCP)
- XON Function
- RoHS Compliant and 100% Lead (Pb)-Free
- Compact Package: QFN4X4-32

### Applications

- GOA TFT-LCD PANEL

### Order Information

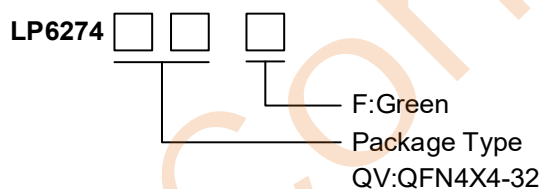

### General Description

The LP6274 includes 12-channel high-voltage level shifter with adjustable gate pattern functions. This device is suitable for GOA TFT-LCD panel application.

The LP6274 transform the logic-level controlled signals, which are generated by the display timing controller (TCON), into the high-level signals needed by LCD panel. Different CKO\_1~8 output patterns will be generated by different external settings. Each channel of level shifter output uses low impedance transistors to achieve fast rising and falling time, even when driving the capacitive loads present in LCD applications.

The LP6274 features extensive protection functions that include UVLO, TOP, SCP and OCP. The device operates over the -40°C to +85°C. It is available in 4mmx4mm, 32-lead QFN package.

### Typical Application Circuit

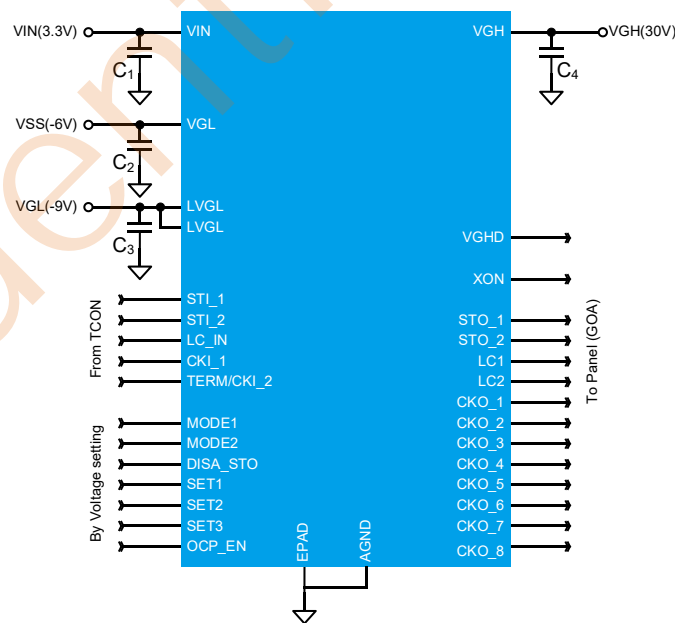

## Device Information

Part Number	Top Marking	Moisture Sensitivity Level	Package	Shipping
LP6274QVF	LPS LP6274 YWXXX	MSL3	QFN4X4-32	3K/REEL

Marking indication:

Y: Year code. W: Week code. XXX: Batch numbers.

## Pin Diagram

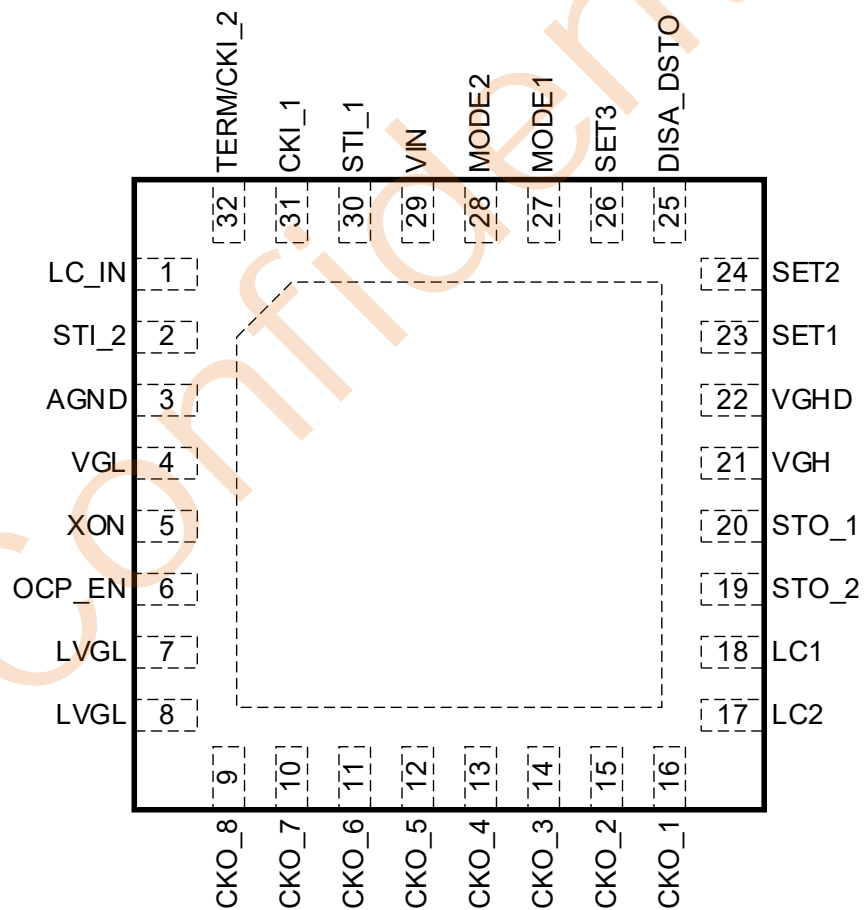

LPQ6274QVF QFN4X4-32

## Pin Description

Pin#	Name	I/O	Description
1	LC_IN	I	Level Shifter Input Signal(Low frequency clock) The LC is the high / low level trigger. This pin is internally connected to a 400kΩ resistance to the GND.
2	STI_2	I	Level Shifter Input Signal. This pin is internally connected to a 400kΩ resistance to the GND.
3	AGND	--	Analog Ground for Logic Block.
4	VGL	P	XON pin negative power supply.
5	XON	O	Discharge function for Liquid Crystal capacitor when panel power off.
6	OCP_EN	I	Setting pin for disable OCP function High level(2.5V~3.6V) : Disable OCP function Floating level(1.2V~2.2V) : OCP Level2 function --- 60mA Low level(0V~0.8V) : OCP Level1 function --- 100mA This pin internal connection respectively 400kΩ resistance to VIN and GND
7	LVGL	P	Negative power supply. Please reference to function block and application circuit.
8	LVGL	P	Negative power supply. Please reference to function block and application circuit.
9	CKO_8	O	Level Shifter Output Signal.
10	CKO_7	O	Level Shifter Output Signal.
11	CKO_6	O	Level Shifter Output Signal.
12	CKO_5	O	Level Shifter Output Signal.
13	CKO_4	O	Level Shifter Output Signal.
14	CKO_3	O	Level Shifter Output Signal.
15	CKO_2	O	Level Shifter Output Signal.
16	CKO_1	O	Level Shifter Output Signal.
17	LC2	O	Level Shifter Output Signal (Low Frequency Clock 2)
18	LC1	O	Level Shifter Output Signal (Low Frequency Clock 1)
19	STO_2	O	Level Shifter Output Signal.
20	STO_1	O	Level Shifter Output Signal.
21	VGH	P	LC1/LC2, STO_1/STO_2, CKO_1~CKO_8, XON, VGHD Positive Power Supply.
22	VGHD	O	VGH Output
23	SET1	I	Setting Pin for Phase Selection. High Level (2.5V~3.6V) : 8 phase Low Level (0V~0.8V) : 6 phase Floating (1.2V~2.2V) : 4 phase Then setting will trigger & latch the phase selection function by first STI_1 rising edge. It is suggested that the pin is fixed by VIN or GND or Floating. The mean of floating is without external voltage or signal. (Don't connect anything) This pin internal connection respectively 400kΩ resistance to VIN and GND

## Pin Description

Pin#	Name	I/O	Description
24	SET2	I	Setting Pin for Clocks Interval. High Level (1.5V~3.6V) : There is some time interval between CKO_s Low Level (0V~0.8V) or Floating : There is no time interval between CKO_s The setting will trigger & latch the clocks interval function by each STI_1 rising edge. It is suggested that the pin is fixed by VIN or GND or Floating The mean of floating is without external voltage or signal. (Don't connect anything) This pin is internally connected to a 400kΩ resistance to the GND.
25	DISA_DSTO	I	Setting Pin for STO_2 output. High Level (1.5V~3.6V) : STO_1 ON (follow STI_1), STO_2 keeps in LVGL Low Level (0V~0.8V) : STO_1 ON (follow STI_1), STO_2 ON (follow STI_2) It is suggested that the pin is fixed by VIN or GND. This pin is internally connected to a 400kΩ resistance to the GND.
26	SET3	I	Setting Clock input mode High level (1.5V~3.6V): 2 clock input mode Low level (0V~0.8V): 1 clock input mode The SET3 will trigger & latch by first STI_1 rising edge. <b>This pin is internally connected to a 400kΩ resistance to VIN.</b>
27	MODE1	I	Setting Pin for Pre-charge selection. Extra High level (3V~4V) : 3-line pre-charge High level (1.5V~2.5V) : 1-line pre-charge Middle level (0.9V~1.4V) : no pre-charge Low level (0V~0.8V) : 2-line pre-charge The MODE1 will trigger & latch by each STI_1 rising edge. This pin is internally connected to a 400kΩ resistance to the GND.
28	MODE2	I	Setting Pin for 1 line mode or 2 line mode selection. High level (1.5V~3.6V) : 2 line mode on Low level (0V~0.8V) : Keep 1 line mode on The MODE2 will trigger & latch by each STI_1 rising edge. It is suggested that pin is fixed by VIN or GND. This pin is internally connected to a 400kΩ resistance to the GND.
29	VIN	P	Supply voltage input.
30	STI_1	I	Level Shifter Input Signal (start pulse for GOA). The corresponding Level Shifter output channel is STO_1. The STI_1 is rising / falling edge trigger. This pin is internally connected to a 400kΩ resistance to the GND.
31	CKI_1	I	Level Shifter Input Signal (Condensed clock) The CKI_1 is the rising / falling level trigger. This pin is internally connected to a 400kΩ resistance to the GND.
32	TERM/CKI_2	I	Level Shifter Input Signal. This pin is multi-function input pin. Setting by SET3 pin SET3 < 0.8V, This pin function is Terminate The Terminate is level trigger. SET3 > 1.5V, This pin function is CKI2 The CKI2 is edge trigger This pin is internally connected to a 400kΩ resistance to the GND.
33	E-PAD	P	The E-Pad should be connected to ground.

## Absolute Maximum Ratings (Note1)

VIN to AGND	-----	-0.3V to +7V
LC_IN, STI_2 to AGND	-----	-0.3V to +7V
VGL to AGND	-----	-20V to +0.3V
XON to AGND	-----	VGL+0.3V to VGH-0.3V
LVGL to AGND	-----	-20V to +0.3V
CKO_1~CKO_8 to AGND	-----	LVGL+0.3V to VGH-0.3V
LC1, LC2 to AGND	-----	LVGL+0.3V to VGH-0.3V
STO_1, STO_2 to AGND	-----	LVGL+0.3V to VGH-0.3V
VGH to AGND	-----	-0.3V to +45V
VGHD to AGND	-----	-0.3V to +45V
SET1, SET2, DISA_DSTO to AGND	-----	-0.3V to +7V
SET3, MODE1, MODE2 to AGND	-----	-0.3V to +7V
STI_1, CKI_1, TERM/CKI_2 to AGND	-----	-0.3V to +7V
VGH to LVGL/VGL	-----	-0.3V to +57V
LVGL to VGL	-----	-20V to +0.3V

**Note1:** Stresses beyond those listed under “Absolute Maximum Ratings” may cause permanent damage to the device. These are stress ratings only, and functional operation of the device at these or any other conditions beyond those indicated in the operational sections of the specifications is not implied. Exposure to absolute maximum rating conditions for extended periods may affect device reliability.

## ESD Ratings (Note2)

HBM (Human Body Model)	-----	3KV
CDM (Charge Discharge Model)	-----	800V

**Note2:** Devices are ESD sensitive. Handling precaution is recommended.

## Thermal Information

Junction Temperature (TJ)	-----	150°C
Operating Junction Temperature Range (TJ)	-----	-40°C to 125°C
Ambient Temperature Range	-----	-40°C to 85°C
Storage Temperature Range	-----	-65°C to 150°C
Maximum Soldering Temperature (at leads, 10 sec)	-----	260°C
$\theta_{JA}$ (Junction-to-Ambient Thermal Resistance)	-----	52°C/W
$\theta_{JC}$ (Junction-to-Case Thermal Resistance)	-----	19°C/W

## Recommended Operating Conditions

Over Operating free-air temperature range (unless otherwise noted)

SYMBOL	PARAMETER	CONDITIONS	MIN	TYP	MAX	UNIT
V <sub>IN</sub>	VIN Supply Range		2.5	3.3	5.5	V
V <sub>GH</sub>			7.0		40	V
V <sub>LVL</sub>			-18		-3.0	V
V <sub>GL</sub>			-18		-3.0	V
SET1 <sub>HIGH</sub>	SET1 Input Level voltage	VIN=2.5V to 5.5V	2.5		3.6	V
SET1 <sub>MIDDLE</sub>		VIN=2.5V to 5.5V	1.2		2.2	V
SET1 <sub>LOW</sub>		VIN=2.5V to 5.5V	0		0.8	V
OCP_EN <sub>HIGH</sub>	OCP_EN Input Level voltage	VIN=2.5V to 5.5V	2.5		3.6	V
OCP_EN <sub>MIDDLE</sub>		VIN=2.5V to 5.5V	1.2		2.2	V
OCP_EN <sub>LOW</sub>		VIN=2.5V to 5.5V	0		0.8	V
MODE1 <sub>EXTRA_H</sub>	MODE1 Input Level voltage	VIN=2.5V to 5.5V	3		4	V
MODE1 <sub>HIGH</sub>		VIN=2.5V to 5.5V	1.5		2.5	V
MODE1 <sub>MIDDLE</sub>		VIN=2.5V to 5.5V	0.9		1.4	V
MODE1 <sub>LOW</sub>		VIN=2.5V to 5.5V	0		0.8	V
SET2 <sub>HIGH</sub>	SET2 Input Level voltage	VIN=2.5V to 5.5V	1.5		3.6	V
SET2 <sub>LOW</sub>		VIN=2.5V to 5.5V	0		0.8	V
SET3 <sub>HIGH</sub>	SET3 Input Level voltage	VIN=2.5V to 5.5V	1.5		3.6	V
SET3 <sub>LOW</sub>		VIN=2.5V to 5.5V	0		0.8	V
MODE2 <sub>HIGH</sub>	MODE2 Input Level voltage	VIN=2.5V to 5.5V	1.5		3.6	V
MODE2 <sub>LOW</sub>		VIN=2.5V to 5.5V	0		0.8	V
V <sub>IH</sub>	Input signal	VIN=2.5V to 5.5V	1.5			V
V <sub>IL</sub>	Input signal	VIN=2.5V to 5.5V			0.8	V

## Electrical Characteristics

VIN = 3.3V, VGH=30V, LVGL=-10V, VGL = -6V, AGND= 0V, TA= 25°C

The device is not guaranteed to function outside its operating conditions. Parameters with MIN and/or MAX limits are 100% tested at +25°C, unless otherwise specified.

SYMBOL	PARAMETER	TEST CONDITIONS	MIN	TYP	MAX	UNIT
<b>GENERAL</b>						
VIN	Supply Voltage		2.5	---	5.5	V
VIN <sub>UVLO_R</sub>	VIN Under Voltage Lockout Threshold	VIN rising, hys=200mV	1.9	2.0	2.1	V
VIN <sub>UVLO_F</sub>	VIN Under Voltage Lockout Threshold	VIN falling	1.7	1.8	1.9	V
VGH <sub>UVLO_R</sub>	VGH Under Voltage Lockout Threshold	VGH rising	6.2	6.55	6.9	V
VGH <sub>UVLO_F</sub>	VGH Under Voltage Lockout Threshold	VGH falling	6.0	6.35	6.7	V
VGH <sub>POR</sub>	VGH Power off reset voltage	VGH falling	3	4	5	V
I <sub>VIN</sub>	VIN Quiescent current	VIN=3.3V, VGH=30V LVGL=VGL=-10V		200	500	uA
I <sub>VGH</sub>	VGH Quiescent current	VGH=30V LVGL=VGL=-10V Don't input control		500	800	uA
I <sub>LVGL</sub>	LVGL Quiescent current	VGH=30V LVGL=VGL=-10V Don't input control		100	300	uA
I <sub>VGL</sub>	VGL Quiescent current	VGH=30V LVGL=VGL=-10V Don't input control		100	300	uA
T <sub>SD</sub>	Thermal Overload Shutdown	Junction Temperature	140	150	160	°C
R <sub>PULL.UP</sub>	Internal Pull UP Resistor	Pull up to VIN	300	400	500	KΩ
R <sub>PULL.DOWN</sub>	Internal Pull Down Resistor	Pull low to GND	300	400	500	KΩ

## Electrical Characteristics

VIN = 3.3V, VGH=30V, LVGL=-10V, VGL = -6V, AGND= 0V, TA= 25°C

The device is not guaranteed to function outside its operating conditions. Parameters with MIN and/or MAX limits are 100% tested at +25°C, unless otherwise specified.

SYMBOL	PARAMETER	TEST CONDITIONS	MIN	TYP	MAX	UNIT
<b>Level Shifter</b>						
VGH	VGH to AGND		7		40	V
VGL/LVGL	LVGL, VGL to AGND	LVGL must be earlier (equal) and the voltage must be lower (equal) than VGL	-18		0	V
	VGH- (LVGL or VGL)	VGH=40V LVGL/VGL=-15V			55	V
VIH	CKI_1, TERM, STI_1, STI_2, LC_IN	VIN=2.5V to 5.5V	1.5			V
VIL	Input Level	VIN=2.5V to 5.5V			0.8	V
VIW	CKI_1, TERM, STI_1, STI_2, LC_IN Input Signal pulse width	VIN=2.5V to 5.5V	300			nS
	CKO_1~CKO_8, STO_1, STO_2, LC1, LC2, Positive Output Swing	Io=10mA	VGH -0.5	VGH -0.2	VGH	V
	VGH, XON Positive Output Swing	Io=10mA	VGH -0.5	VGH -0.2	VGH	V
	STO_1, STO_2, LC1, LC2 Negative output swing	Io=-10mA	LVGL	LVGL +0.2	LVGL +0.5	V
	XON Negative output swing	Io=-10mA	VGL	VGL +0.2	VGL +0.5	V
R <sub>HIGH-SIDE</sub>	STO_1/2, LC1/2, XON, VGH, High-side switch-on Resistance	Io=10mA	8	10	15	Ω
R <sub>LOW-SIDE</sub>	STO_1/2, LC1/2 Low-side switch-on Resistance	Io=-10mA	6	8	12	Ω
R <sub>LOW-SIDE</sub>	XON Low-side switch-on Resistance	Io=-10mA	2.4	4	6	Ω
T <sub>R</sub>	STO_1,STO_2,LC1,LC2 Rising Time	VGH=30V, LVGL=-10V, RL=50Ω, CL=4.7nF, 10%~90%	200	300		V/uS
T <sub>F</sub>	STO_1,STO_2,LC1,LC2 Falling Time	VGH=30V, LVGL=-10V, RL=50Ω, CL=4.7nF, 90%~10%	200	300		V/uS
T <sub>RD</sub>	STO_1,STO_2,LC1,LC2 Rising Edge Delay Time	VGH=30V, LVGL=-10V, 50% input to 10% output		100	150	nS
T <sub>FD</sub>	STO_1,STO_2,LC1,LC2 Falling Edge Delay Time	VGH=30V, LVGL=-10V, 50% input to 90% output		100	150	nS
T <sub>XON</sub>	XON Rising Time	VGH=30V, VGL=-6V, RL=51Ω, CL=4.7nF, 10%~90%	400	500		V/uS

## Electrical Characteristics

VIN = 3.3V, VGH=30V, LVGL=-10V, VGL = -6V, AGND= 0V, TA= 25°C

The device is not guaranteed to function outside its operating conditions. Parameters with MIN and/or MAX limits are 100% tested at +25°C, unless otherwise specified.

SYMBOL	PARAMETER	TEST CONDITIONS	MIN	TYP	MAX	UNIT
<b>Level Shifter</b>						
	CKO_1~CKO_8 Negative output swing	I <sub>o</sub> =-10mA	LVGL	LVGL +0.2	LVGL +0.5	V
R <sub>HIGH-SIDE</sub>	CKO_1~CKO_8 High-side switch-on Resistance	I <sub>o</sub> =10mA	8	10	15	Ω
R <sub>LOW-SIDE</sub>	CKO_1~CKO_8 Low-side switch-on Resistance	I <sub>o</sub> =-10mA	6	8	12	Ω
T <sub>R</sub>	CKO_1~CKO_8 Rising Time	VGH=30V, LVGL=-10V, RL=50Ω, CL=4.7nF, 10%~90%	400	500		V/uS
T <sub>F</sub>	CKO_1~CKO_8 Falling Time	VGH=30V, LVGL=-10V, RL=50Ω, CL=4.7nF, 90%~10%	400	500		V/uS
T <sub>RD</sub>	CKO_1~CKO_8 Rising Edge Delay Time	VGH=30V, LVGL=-10V, 50% input to 10% output		100	150	nS
T <sub>FD</sub>	CKO_1~CKO_8 Falling Edge Delay Time	VGH=30V, LVGL=-10V, 50% input to 90% output		100	150	nS
T <sub>VGHD_DLY</sub>	VGHD Power on delay time		60	66	72	mS
T <sub>VGH_SS</sub>	VGHD power on soft start time	Co=4.7uF	3	5		mS
T <sub>VGHD_MASK</sub>	VGH power on mask time		128	148	168	mS

## Electrical Characteristics

VIN = 3.3V, VGH=30V, LVGL=-10V, VGL = -6V, AGND= 0V, TA= 25°C

The device is not guaranteed to function outside its operating conditions. Parameters with MIN and/or MAX limits are 100% tested at +25°C, unless otherwise specified.

SYMBOL	PARAMETER	TEST CONDITIONS	MIN	TYP	MAX	UNIT
<b>Level Shifter Over current &amp; time setting</b>						
STO <sub>BT</sub>	STO blanking time		8.1	9	9.9	uS
STO <sub>HDE</sub>	STO high-side de-noise time		1.6	2	2.4	uS
STO <sub>LDE</sub>	STO low-side de-noise time		460.8	512	563.2	uS
LC <sub>BT</sub>	LC1/2 blanking time		8.1	9	9.9	uS
LC <sub>HDE</sub>	LC1/2 high-side de-noise time		460.8	512	563.2	uS
LC <sub>LDE</sub>	LC1/2 low-side de-noise time		460.8	512	563.2	uS
XON <sub>BT</sub>	XON blanking time		8.1	9	9.9	uS
XON <sub>LDE</sub>	XON low-side de-noise time		460.8	512	563.2	uS
CKO <sub>BT</sub>	CKO blanking time		8.1	9	9.9	uS
CKO <sub>HDE</sub>	CKO high-side de-noise time		1.6	2	2.4	uS
CKO <sub>LDE</sub>	CKO low-side de-noise time		1.6	2	2.4	uS
STO <sub>BT</sub>	STO blanking time		8.1	9	9.9	uS
STO <sub>HDE</sub>	STO high-side de-noise time		1.6	2	2.4	uS
STO <sub>H-LIMIT</sub>	STO high-side OCP level	OCP_EN=LOW	100	120	140	mA
STO <sub>L-LIMIT</sub>	STO low-side OCP level	OCP_EN=LOW	100	120	140	mA
LC <sub>H-LIMIT</sub>	LC high-side OCP level	OCP_EN=LOW	100	120	140	mA
LC <sub>L-LIMIT</sub>	LC low-side OCP level	OCP_EN=LOW	100	120	140	mA
CKO <sub>H-LIMIT</sub>	CKO high-side OCP level	OCP_EN=LOW	100	120	140	mA
CKO <sub>L-LIMIT</sub>	CKO low-side OCP level	OCP_EN=LOW	100	120	140	mA
XON <sub>L-LIMIT</sub>	XON low-side OCP level	OCP_EN=LOW	100	120	140	mA
STO <sub>H-LIMIT</sub>	STO high-side OCP level	OCP_EN=MIDDLE	60	80	100	mA
STO <sub>L-LIMIT</sub>	STO low-side OCP level	OCP_EN=MIDDLE	60	80	100	mA
LC <sub>H-LIMIT</sub>	LC high-side OCP level	OCP_EN=MIDDLE	60	80	100	mA
LC <sub>L-LIMIT</sub>	LC low-side OCP level	OCP_EN=MIDDLE	60	80	100	mA
CKO <sub>H-LIMIT</sub>	CKO high-side OCP level	OCP_EN=MIDDLE	60	80	100	mA
CKO <sub>L-LIMIT</sub>	CKO low-side OCP level	OCP_EN=MIDDLE	60	80	100	mA
XON <sub>L-LIMIT</sub>	XON high-side OCP level	OCP_EN=MIDDLE	60	80	100	mA

## Electrical Characteristics

VIN = 3.3V, VGH=30V, LVGL=-10V, VGL = -6V, AGND= 0V, TA= 25°C

The device is not guaranteed to function outside its operating conditions. Parameters with MIN and/or MAX limits are 100% tested at +25°C, unless otherwise specified.

SYMBOL	PARAMETER	TEST CONDITIONS	MIN	TYP	MAX	UNIT
<b>Level Shifter Short current &amp; time setting (OCP Disable)</b>						
STO <sub>DT</sub>	STO SCP detect time		16	20	24	uS
LC <sub>DT</sub>	LC1/2 SCP detect time		16	20	24	uS
XON <sub>DT</sub>	XON SCP detect time		16	20	24	uS
CKO <sub>SCP_BT</sub>	CKO SCP blanking time		8.1	9	9.9	uS
CKO <sub>SCP_DT1</sub>	CKO SCP detect time1		1.6	2	2.4	uS
CKO <sub>SCP_DT2</sub>	CKO SCP detect time1		16	20	24	uS
CH <sub>SCP_L</sub>	Channel output SCP level		250	300		mA

Confidential

## Functional Block Diagram

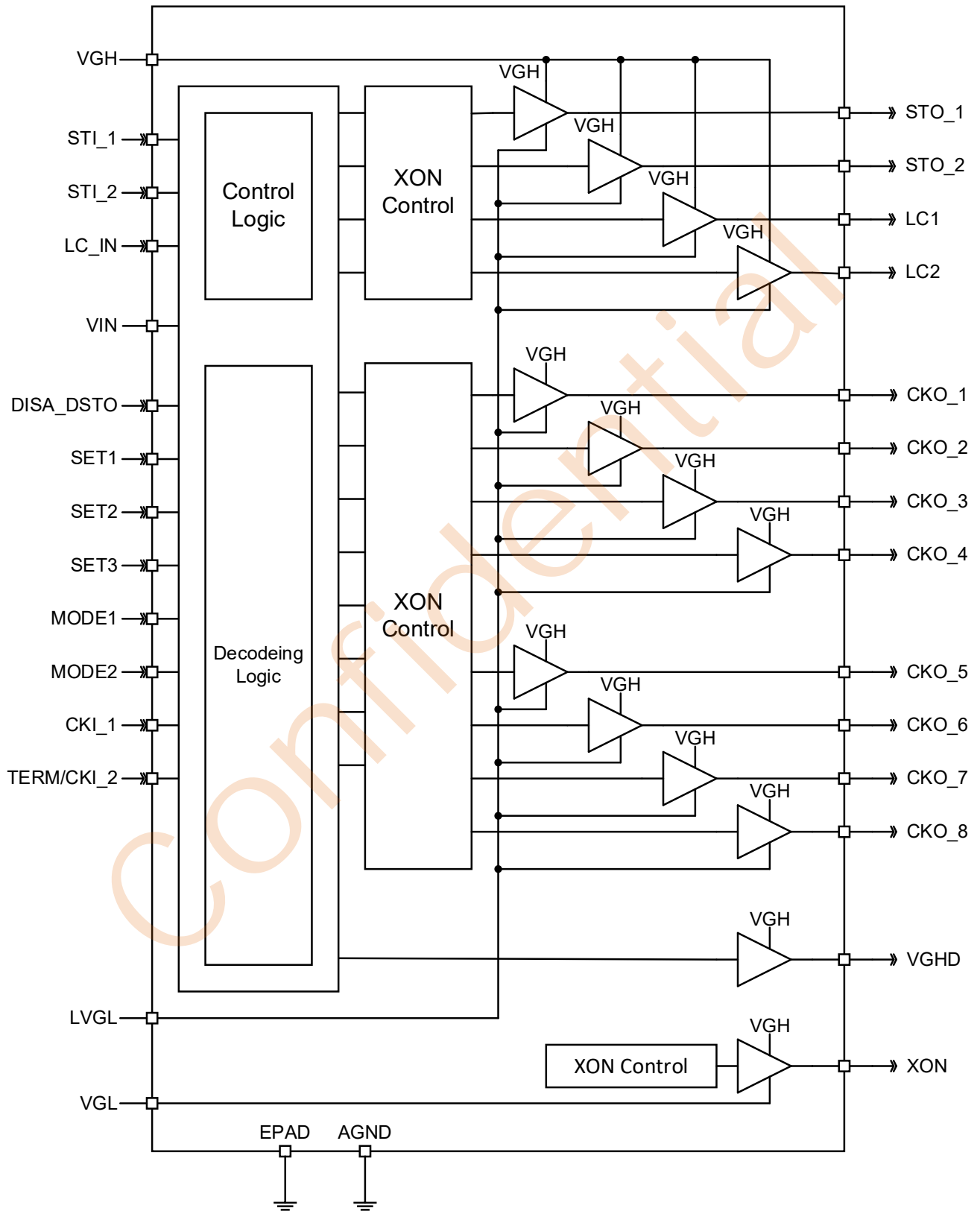

## Typical Application Circuit\_1

SET3=Low

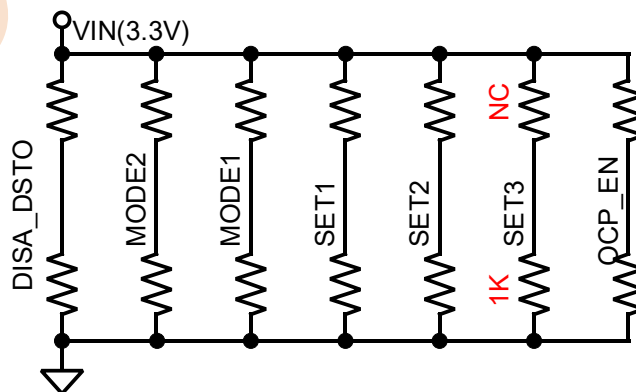
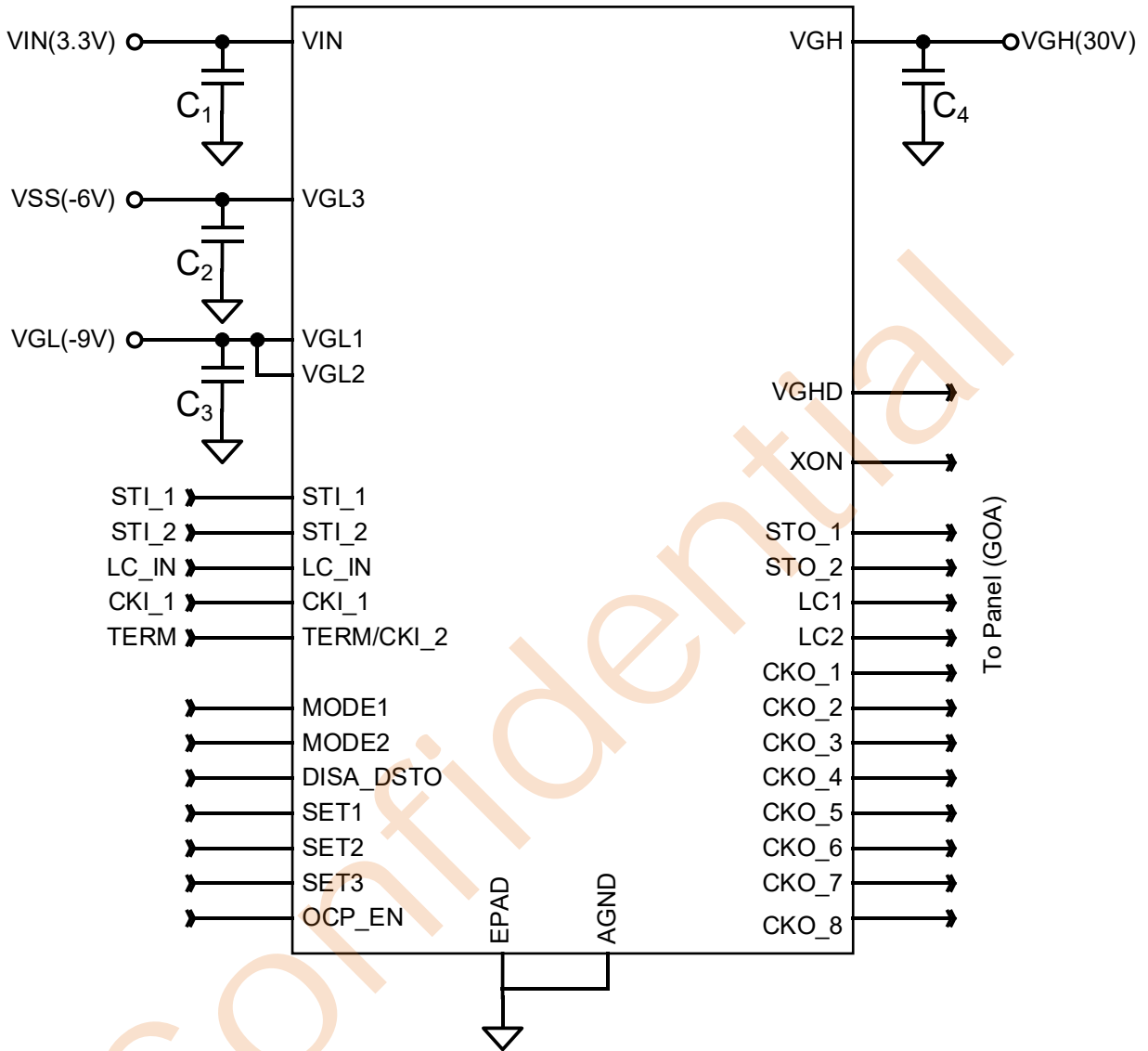

Figure 1. Typical Application Circuit with one in Multi-out

## Typical Application Circuit\_2

SET3=High

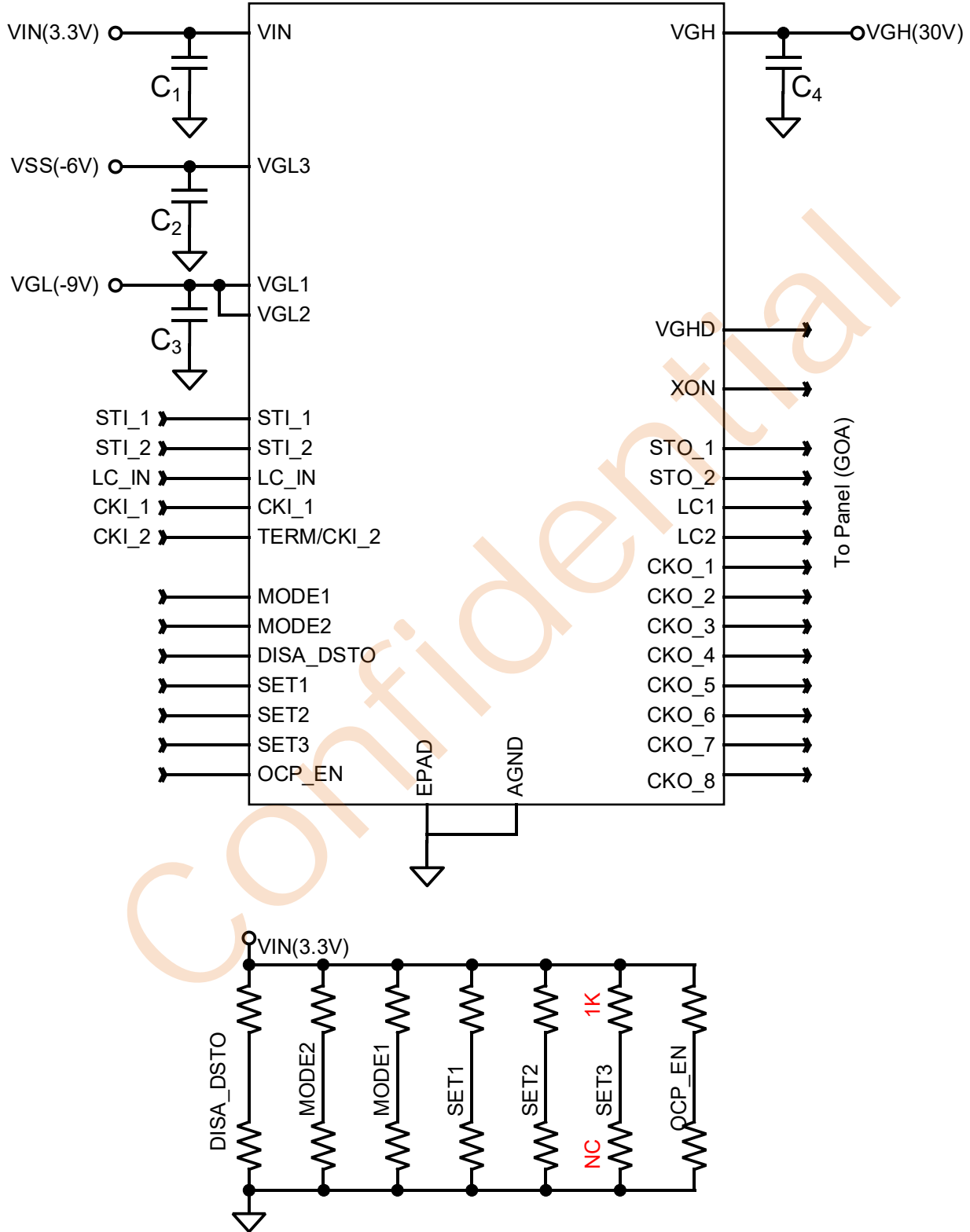

Figure 2. Typical Application Circuit with two in Multi-out

## Component List of Figure Recommended

Components	Part Number	Description	Package	Supplier
C1	CL10A106KP8NNNC	10uF/10V, X5R	C0603	SAMSUNG
C2	CL21A106KOQNNNE	10uF/16V, X5R	C0805	SAMSUNG
C3	CL21A106KOQNNNE	10uF/16V, X5R	C0805	SAMSUNG
C4	CL21A475KBQNNNE	4.7uF/50V, X5R	C0805	SAMSUNG

Resistors are set according to application requirements

Confidential

## General Description

The LP6274QVF provides 14-channel level shifter designed to drive the GOA panel. This device converts the logic-level signals generated by the Timing Controller (T-CON) to high-level signals required by GOA panel.

## Power On Sequence

When the VIN exceeds VIN\_UVLO, the internal signal ENA for condensed GOA logic will be high. The outputs of Level Shifter STO\_1, STO\_2 should follow LVGL, CKO\_1~CKO\_8 should follow LVGL, and XON should follow VGL. The outputs of Level Shifter LC1 and LC2 should follow LC transient one VGH the other LVGL since VIN exceeds UVLO. After ENA high, CKO\_1~CKO\_8 do not output since receiving the first STI\_1 rising edge. After ENA high, LC1 and LC2 will follow LC true table transient.

LC true table		
LC_IN(from TCON)	0	1
LC1	0	1
LC2	1	0

The recommended power-on sequence is

VIN(2.5V~5.5V)→LVGL→VGL→VGH or VIN(2.5V~5.5V)→LVGL/VGL→VGH

The concern of IC design is focus on LVGL and VGL ESD diode. The most negative voltage must be ready before the other two negative voltage.

Confidential

## Power On Condition Table

Case	Analog Power Input			Logic Input			Analog Output			
	VIN	VGH	LVGL VGL	STI_1/2	CKI_1	LC_IN	STO_1/2	CKO_1 ~8	LC1/2	XON
1	>UVLO	>UVLOGH	Don't care	w/i signal	w/i signal	w/i signal	Normal Operation	Normal Operation	LC1=LC LC2=/LC1	VGL
2	>UVLO	>UVLOGH	Don't care	w/i signal	w/o signal	w/i signal	Normal Operation	LVGL	LC1=LC LC2=/LC1	VGL
3	>UVLO	>UVLOGH	Don't care	w/o signal	w/i signal	w/i signal	LVGL	LVGL	LC1=LC LC2=/LC1	VGL
4	>UVLO	>UVLOGH	Don't care	w/i signal	w/i signal	w/o signal	Normal Operation	Normal Operation	LC1=LC LC2=/LC1	VGL
5	>UVLO	>UVLOGH	Don't care	w/o signal	w/i signal	w/o signal	LVGL	LVGL	LC1=LC LC2=/LC1	VGL
6	>UVLO	<UVLOGH >POR	Don't care	Don't care	Don't care	Don't care	LVGL	LVGL	LC1=LC LC2=/LC1	VGL
7	>UVLO	<POR	Don't care	Don't care	Don't care	Don't care	LVGL	LVGL	LVGL	VGL
8	<UVLO	>POR	Don't care	Don't care	Don't care	Don't care	LVGL	LVGL	Hi-Z	VGL
9	<UVLO	<POR	Don't care	Don't care	Don't care	Don't care	LVGL	LVGL	LVGL	VGL

Power on (from 0 to VIN) Condition list-1

Case	Analog Power Input			Logic Input		Analog Output	
	VIN	VGH	LVGL VGL	STI_1	STI_2	STO_1	STO_2
1	>UVLO	>UVLOGH	Don't care	w/i signal	w/i signal	Normal Operation	Normal Operation
2	>UVLO	>UVLOGH	Don't care	w/i signal	w/o signal	Normal Operation	LVGL
3	>UVLO	>UVLOGH	Don't care	w/o signal	w/i signal	LVGL	Normal Operation
4	>UVLO	>UVLOGH	Don't care	w/o signal	w/o signal	LVGL	LVGL
5	>UVLO	<UVLOGH	Don't care	Don't care	Don't care	LVGL	LVGL
6	<UVLO	<UVLOGH	Don't care	Don't care	Don't care	LVGL	LVGL
7	<UVLO	>UVLOGH	Don't care	Don't care	Don't care	LVGL	LVGL

Power on (from 0 to VIN) Condition list-2

## Power On Sequence

VIN>VGH>Mask STO\_1, CKO\_1~CKO\_8 148ms

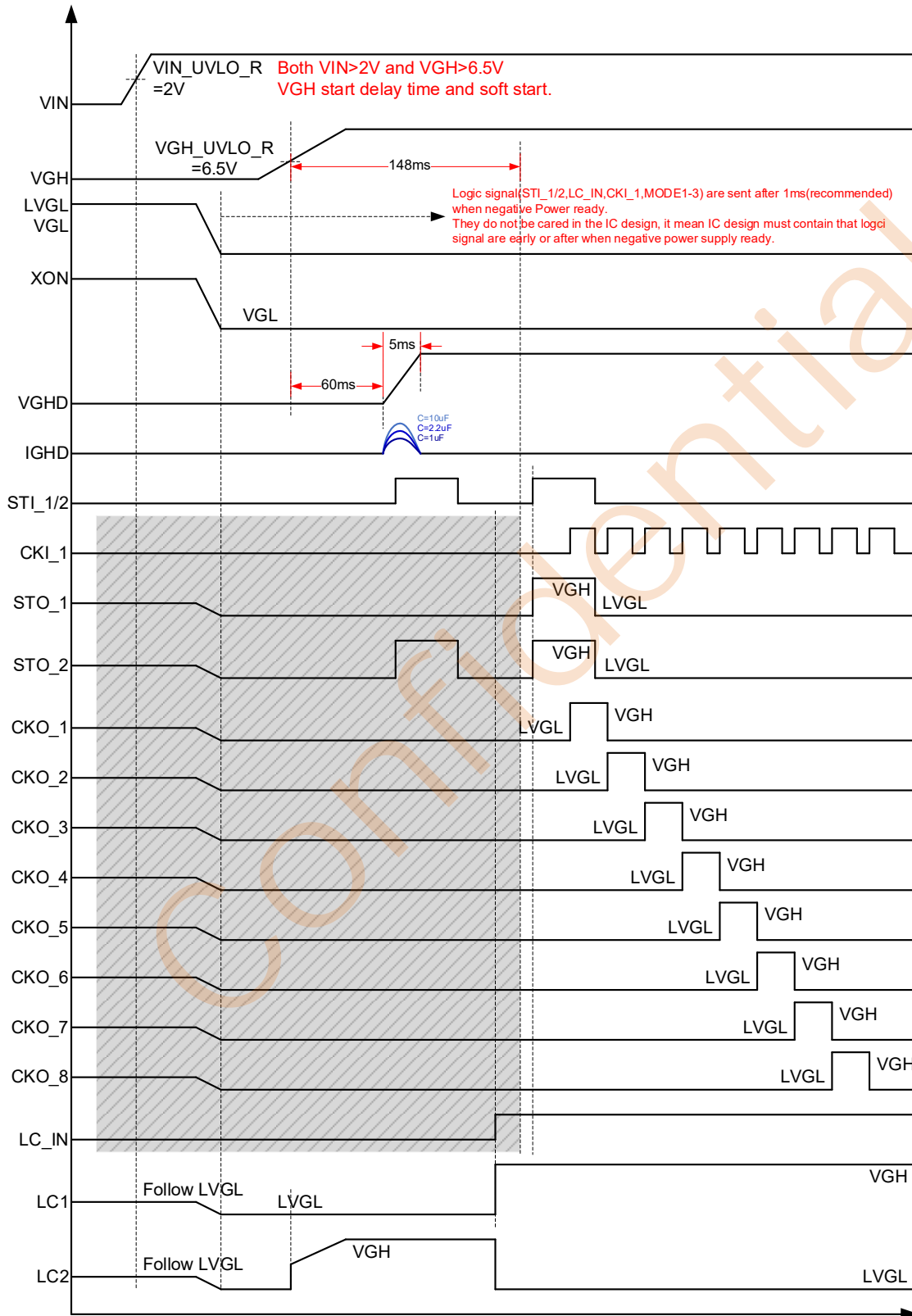

## Power Off Sequence:

Once the VIN falls below the UVLO\_F threshold, LP6274QVF will have the following actions. Pulling all level shift output as high level (including XON, VGHD, STO\_1, STO\_2, LC1, LC2 and CKO\_1~CKO\_8)

Case	Analog Power Input			Logic Input			Analog Output				
	VIN	VGH	LVGL VGL	STI_1	CKI_1	LC_IN	STO_1	CKO_1 ~8	LC1/2	XON	VGHD
1	>UVLO	<UVLO_F >POR	Don't care	Don't care	Don't care	Don't care	LVGL	LVGL	LC1=LC LC2=/LC1	VGL	Hi-Z
2	>UVLO	<POR	Don't care	Don't care	Don't care	Don't care	LVGL	LVGL	LVGL	VGL	Hi-Z
3	<UVLO	>UVLO_F	Don't care	YES	Don't care	Don't care	Follow VGH	Follow VGH	Follow VGH	Follow VGH	Hi-Z
4	<UVLO	>UVLO_F	Don't care	NO	Don't care	Don't care	LVGL	LVGL	LC1=LC LC2=/LC1	VGL	Hi-Z
5	<UVLO	<UVLO_F	Don't care	YES	Don't care	Don't care	Follow VGH	Follow VGH	Follow VGH	Follow VGH	Hi-Z
6	<UVLO	<UVLO_F	Don't care	NO	Don't care	Don't care	LVGL	LVGL	LC1=LC LC2=/LC1	VGL	Hi-Z
7	<UVLO	<VGH_POR	Don't care	YES	Don't care	Don't care	LVGL	LVGL	LVGL	VGL	Hi-Z

Power off (from VIN to 0) Condition list

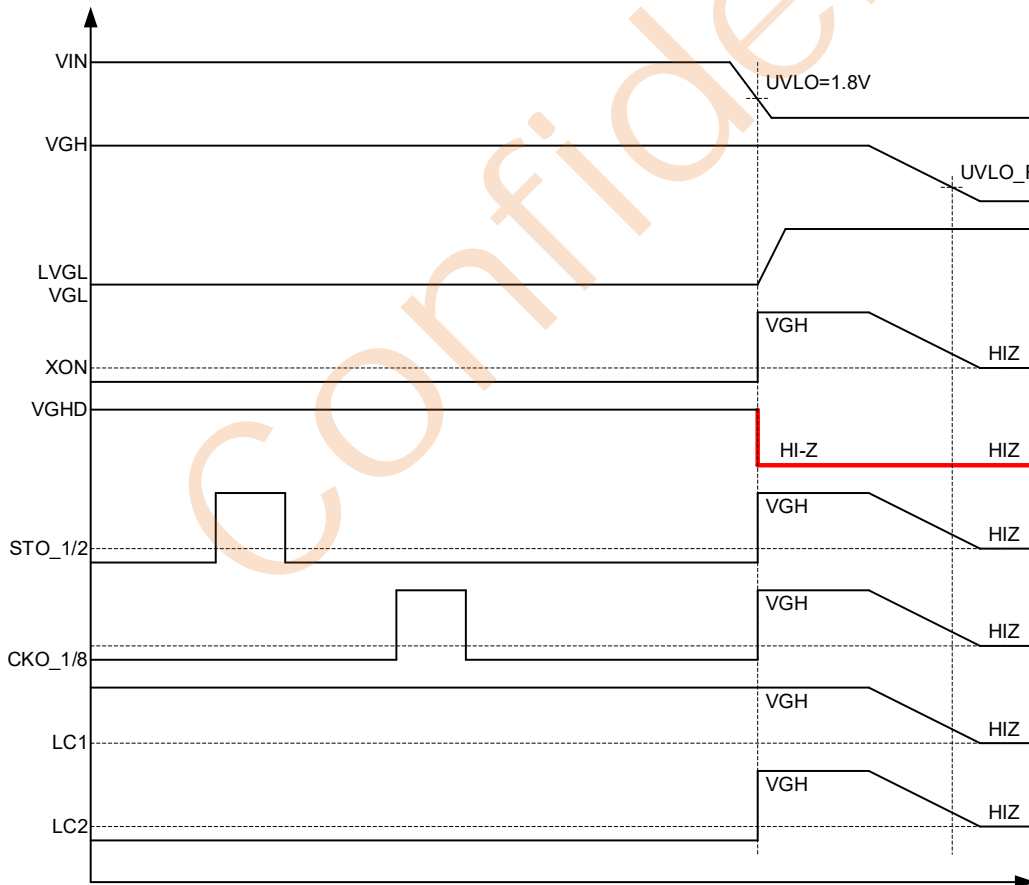

Power off sequence (A) VIN UVLO output waveform

## Level Shift Function

The LP6274QVF contains 12 channels level shifter. It is for GOA (Gate On Array) tech. There are 4 signals to generate STO\_1~2, LC1~2, and CKO\_1~8. VGL is the low voltage level for XON. LVGL is the low voltage level for CKO\_1~8. LVGL is the low voltage level for STO\_1~2 and LC1~2. Settings about level shifter output are listed below.

### Function Setting:

PIN	Status	Level Shifter output
SET1	High level	8 phases. CKO_1~CKO_8 output
	Low level	6 phases. CKO_1~CKO_6 output CKO_7~CKO_8 keep in LVGL
	Floating	4 phases. CKO_1~CKO_4 output CKO_5~CKO_8 keep in LVGL
SET2	High level	There is some time interval between CKO.
	Low/Floating	There is no time interval between CKO.
SET3	High level/Floating	2-in clock control CKO output
	Low level	1-in clock control CKO output
MODE1	Extra High	3-line pre-charge
	High	1-line pre-charge
	Low	2-line pre-charge
	Middle	No pre-charge
MODE2	High level	CKO 2-line mode phase output
	Low/Floating	CKO 1-line mode phase output
DISA_DSTO	High level	STO_2 follow LVGL
	Low/Floating	STO_2 follow STI_2
OCP_EN	High level	OCP disable
	Floating, Middle	60mA
	Low level	100mA

## TERM/CKI\_2

This is a combination two function pin. When SET3<0.8V. This is a terminate input pin. Then Terminate input pin is used to pull low the CKO\_1~CKO\_8 and no more CKI\_1 edges can trigger them before next STI\_1. CKO\_1~CKO\_8 can be terminated by next STI\_1 if the terminate pin isn't stimulated. When SET3>1.5V. The second function is CKI\_2 to define 2 input mode clock output falling edge timing.

## LC\_IN

For GOA circuit. Tow low frequency and complementary signals are needed. LC1 will follow LC\_IN and LC2 will be the inverting of LC1.

## Setting

Level shifter output will be 1-line CKO\_S,4-phase, some time interval, and no pre-charge if the settings are not supported. For example, 4-phase with 2-line pre-charge, 2-line CKO\_s, some time interval or no time interval, those settings will be led to 1-line CKO\_s, 4-phase, time interval, and no pre-charge. The MODE1~2, SET 1~3, OCP\_EN will trigger & latch the function by each STI\_1 rising edge. The entire setting table is listed on appendix.

### SET1:

SET1 pin is to set the phase number of CKO\_s.

PIN	Status	Level Shifter output
SET1	High level	8 phases. CKO_1~CKO_8 output
	Low level	6 phases. CKO_1~CKO_6 output CKO_7~CKO_8 keep in LVGL
	Floating	4 phases. CKO_1~CKO_4 output CKO_5~CKO_8 keep in LVGL

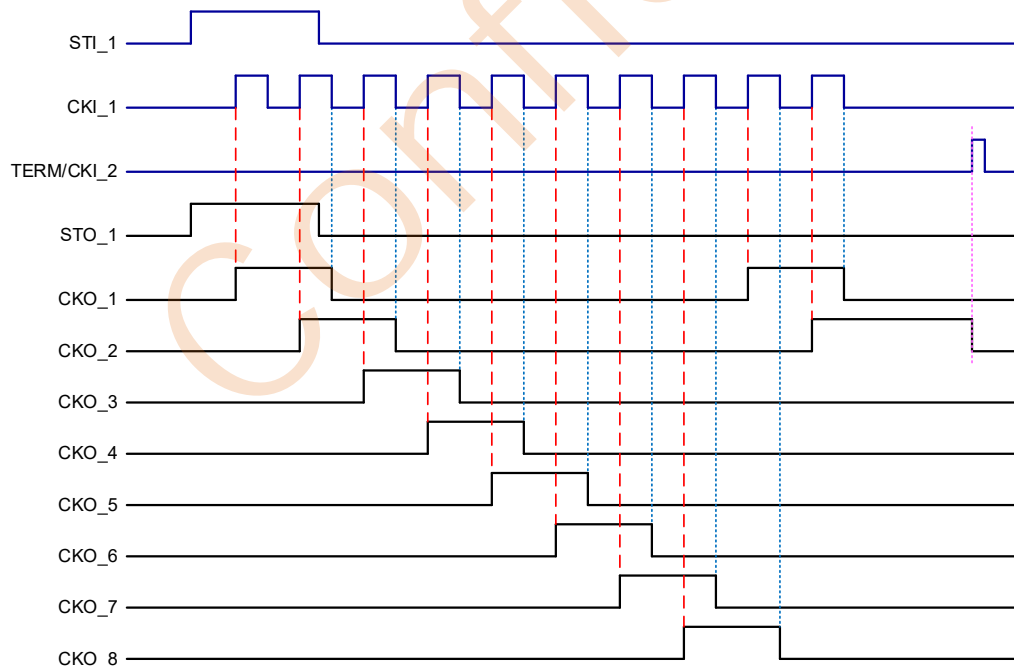

**SET3=Low: 1 input mode ; SET1=High: 8 phase**

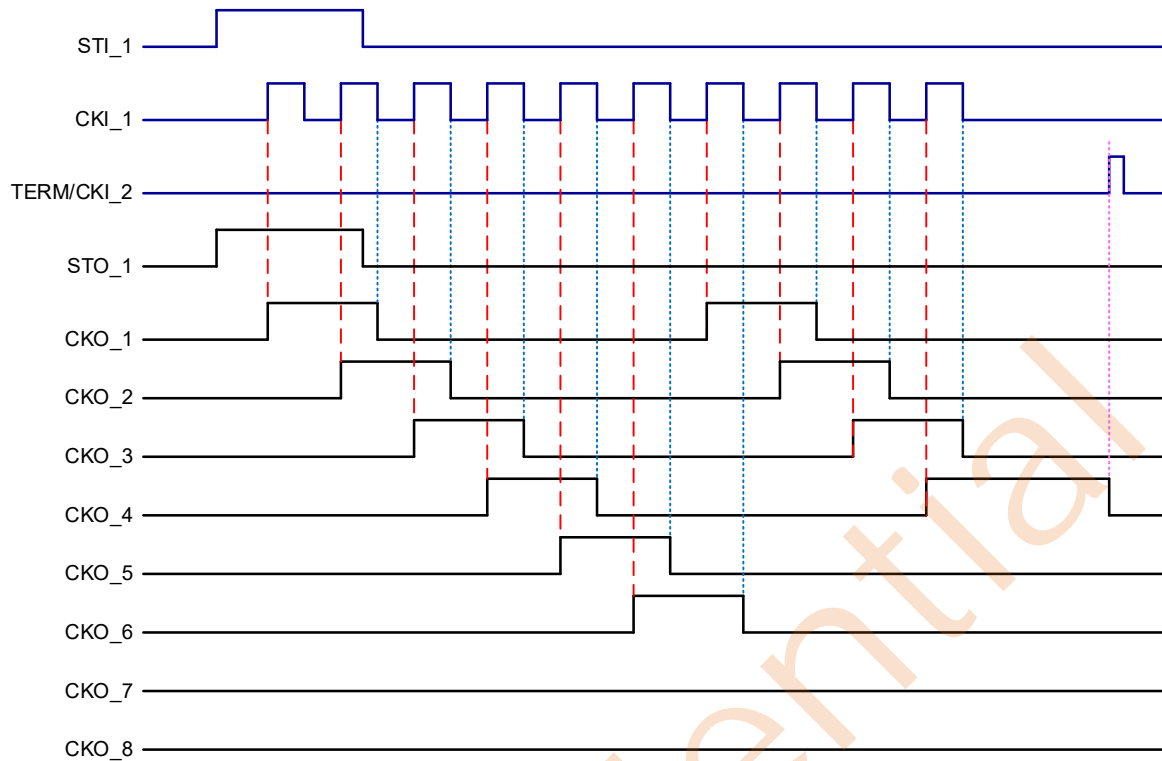

**SET3=Low: 1 input mode ; SET1=Low: 6 phase**

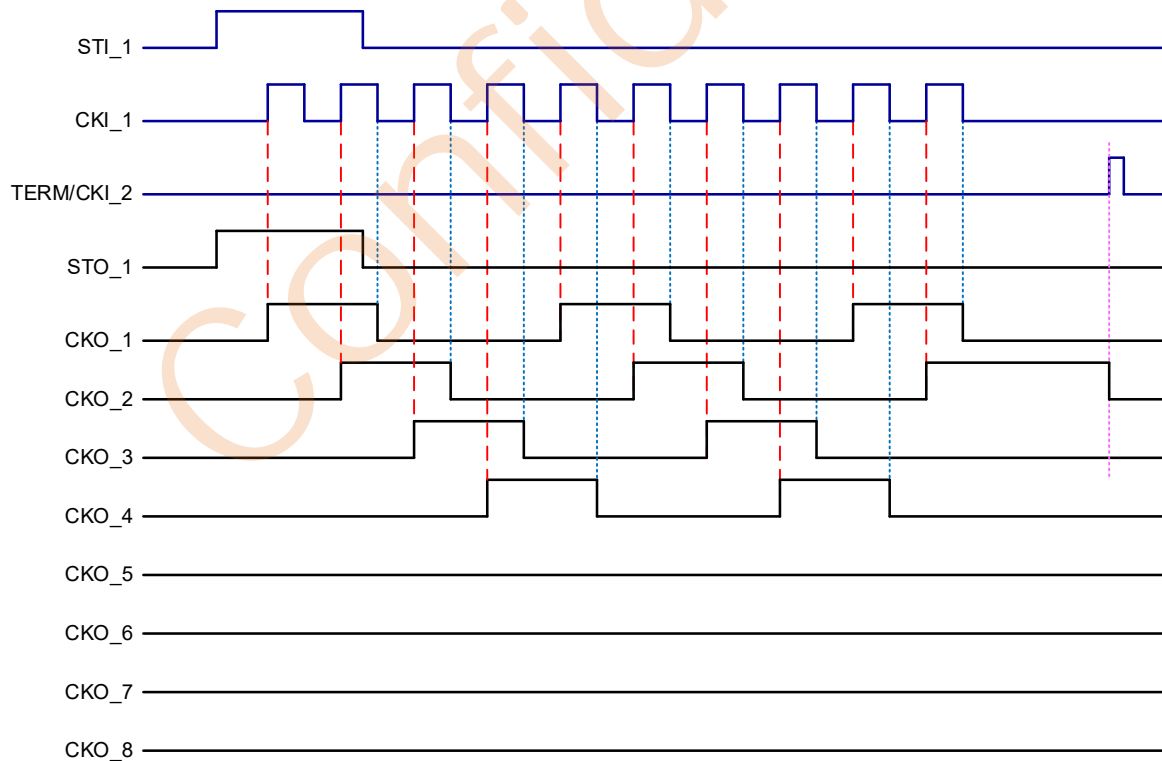

**SET3=Low: 1 input mode ; SET1=Floating: 4 phase**

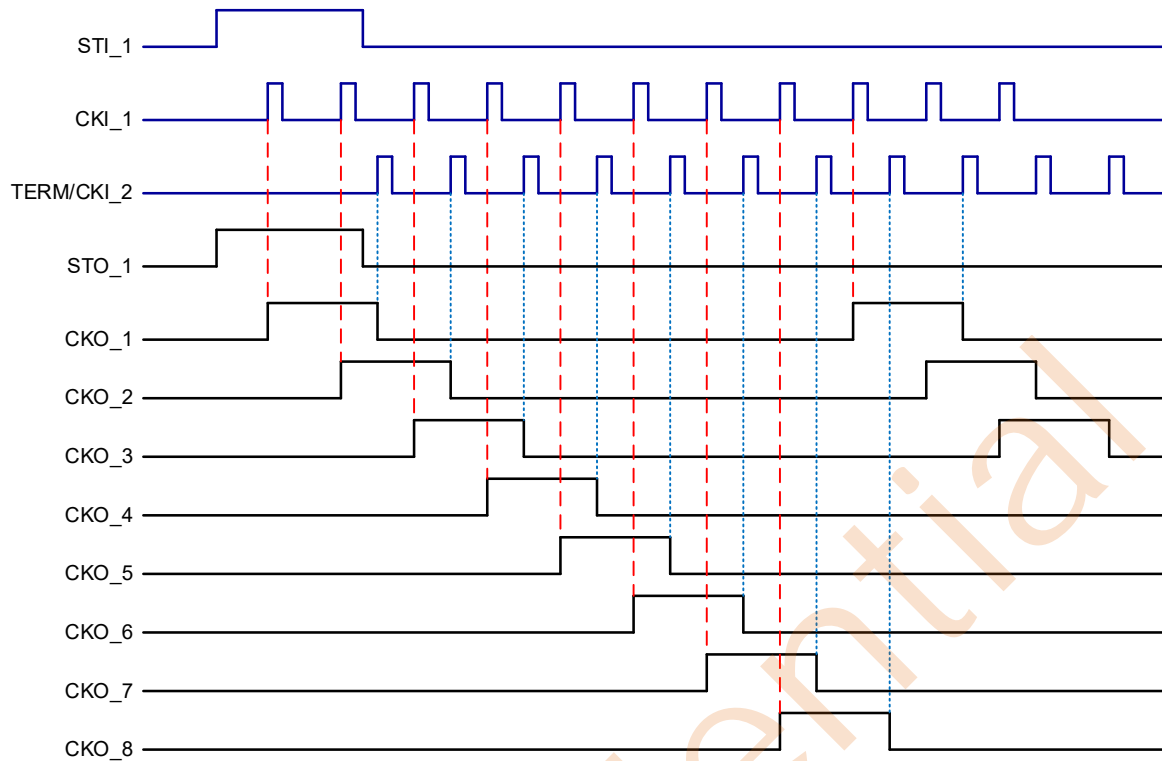

**SET3=High: 2 input mode ; SET1=High: 8 phase**

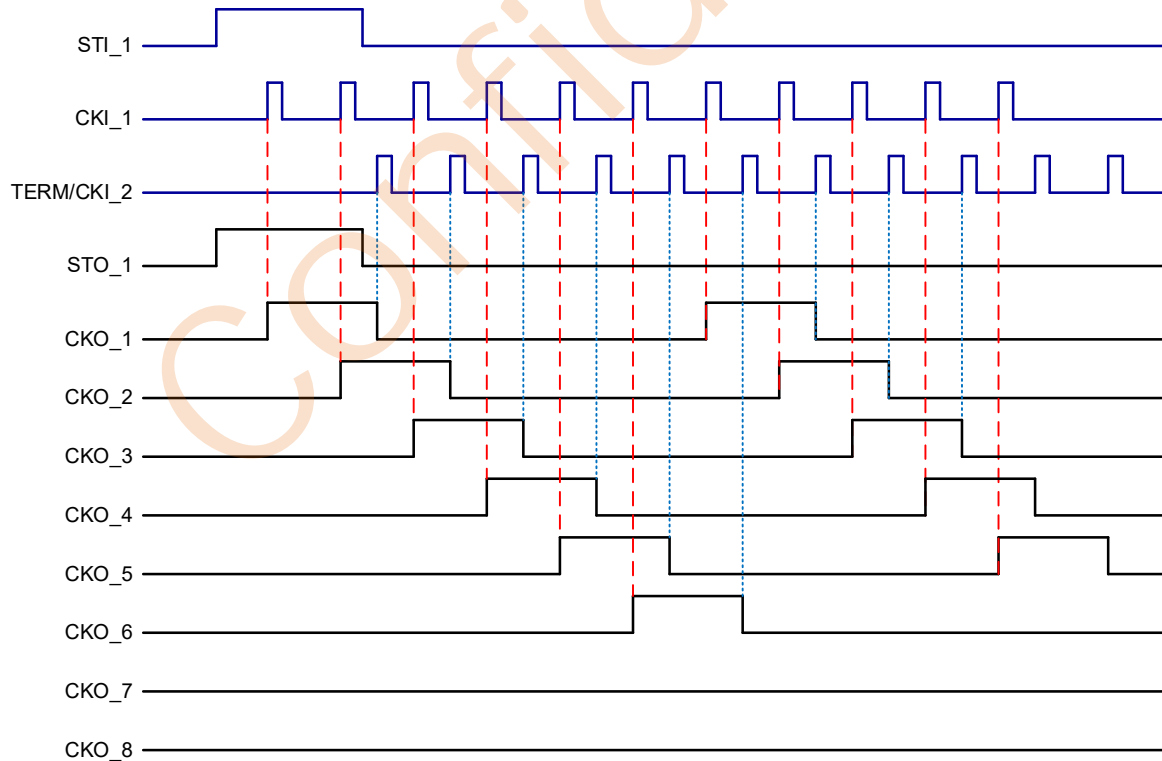

**SET3=High: 2 input mode ; SET1=Low: 6 phase**

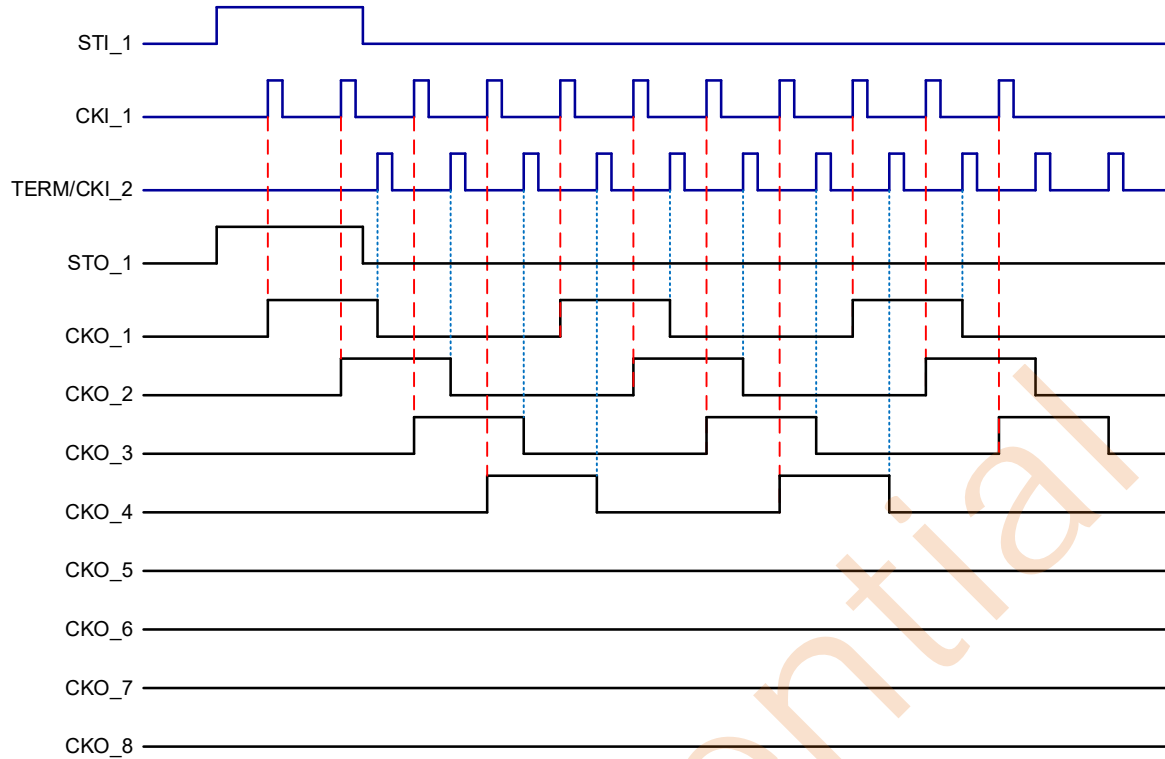

**SET3=High: 2 input mode ; SET1=Floating: 4 phase**

Confidential

**SET2:**

SET2 pin is to set some time / no time interval between CKO\_s.

PIN	Status	Level Shifter output
SET2	High level	Some time interval
	Low/Floating	No time interval

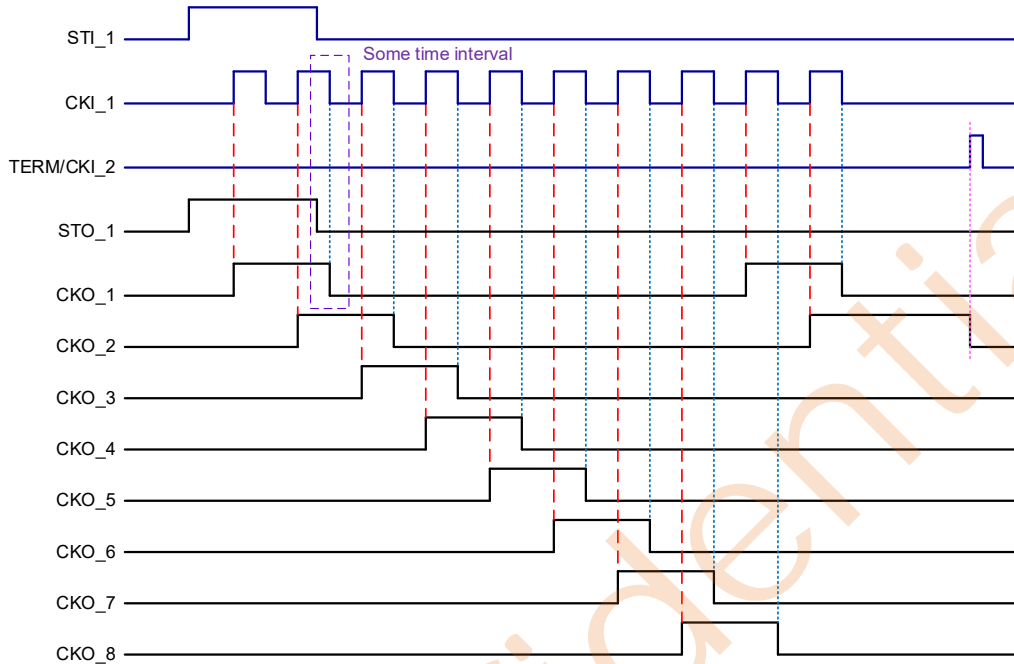

**SET1=High: 8 phase ; SET2=High: Some time**

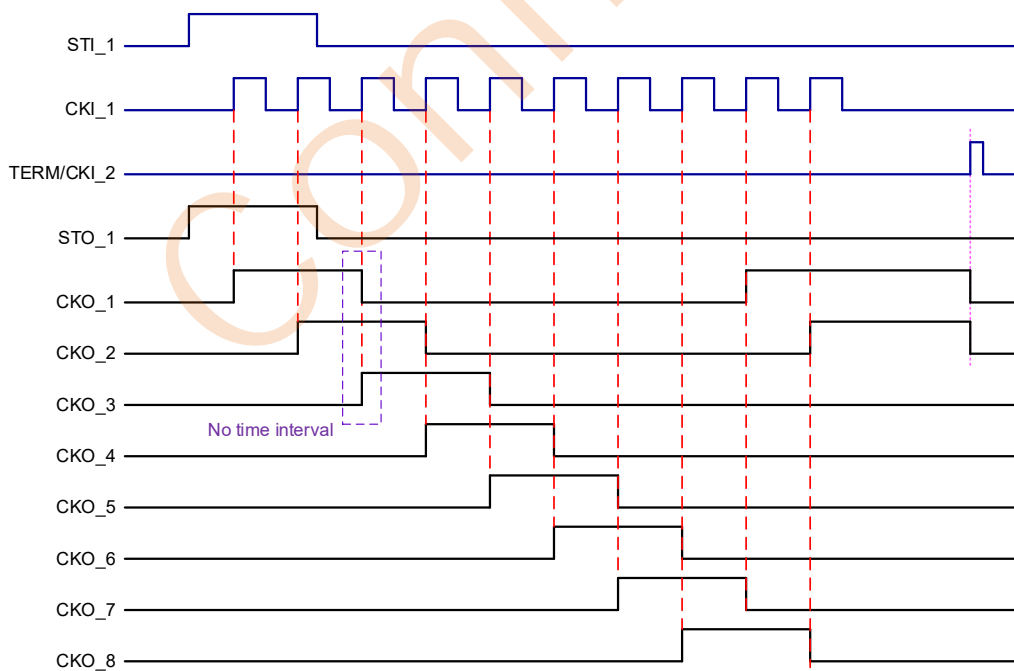

**SET1=High: 8 phase ; SET2=Low: No time**

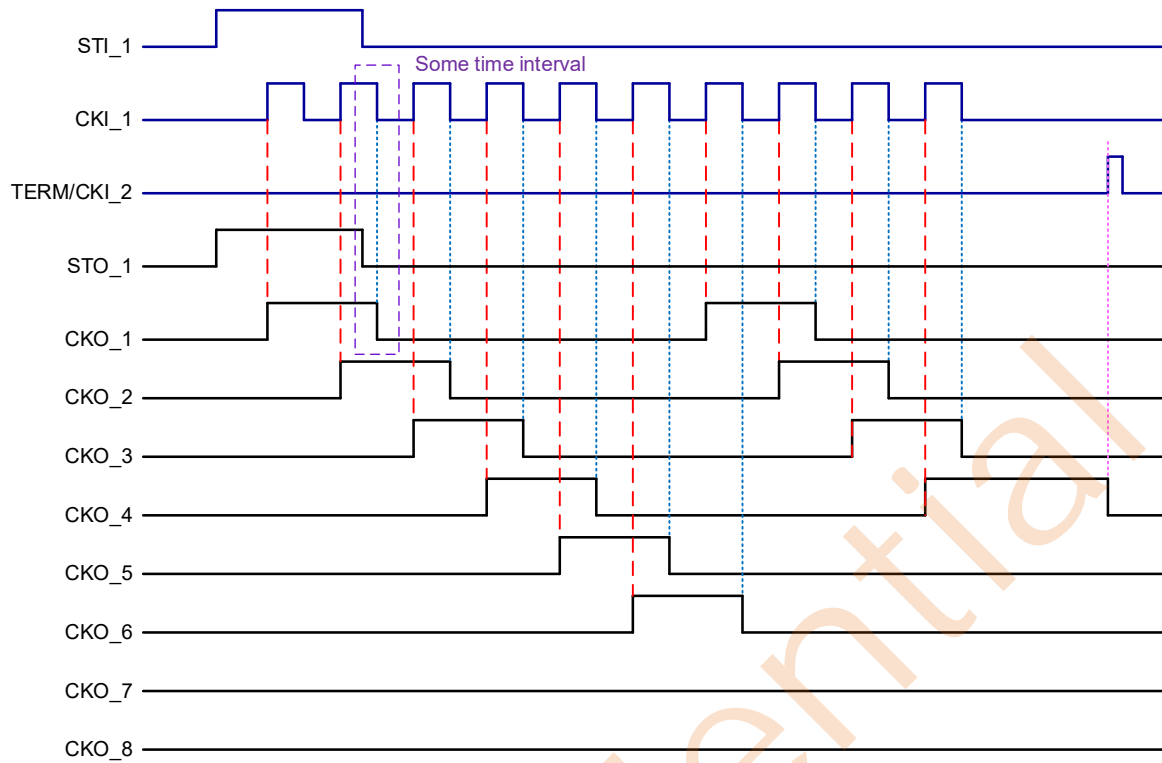

**SET1=Low: 6 phase ; SET2=High: Some time**

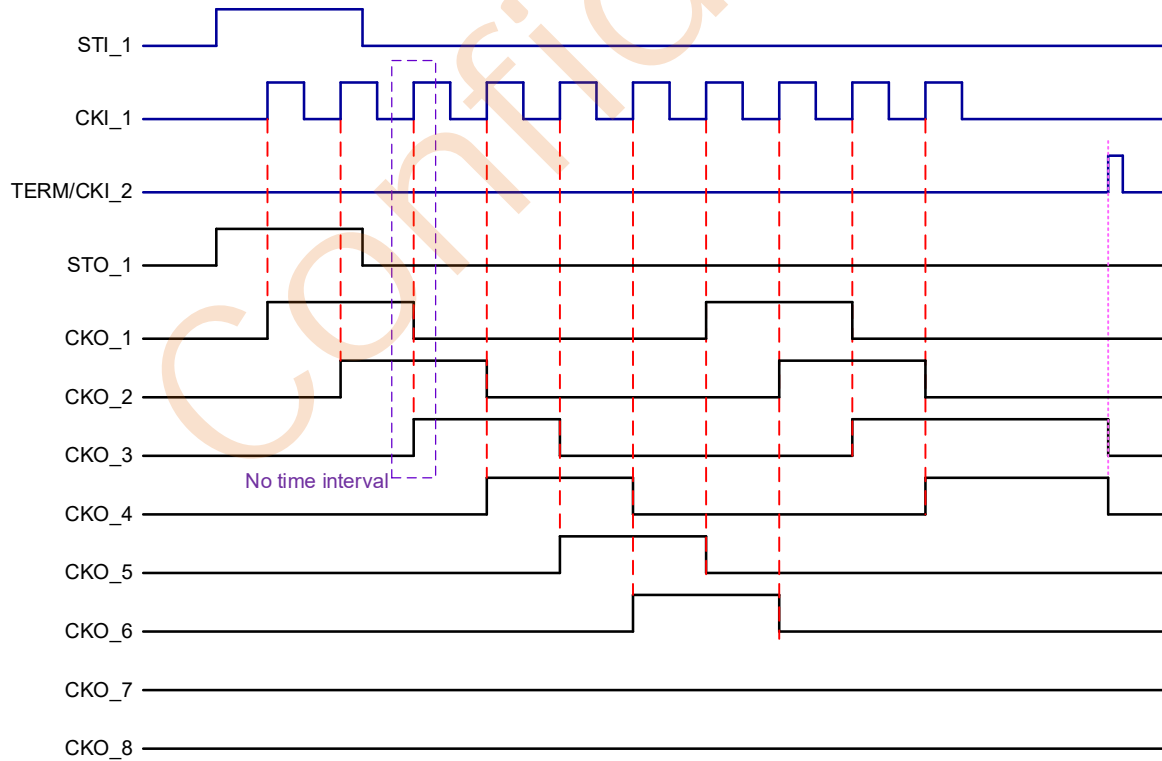

**SET1=Low: 6 phase ; SET2=Low: No time**

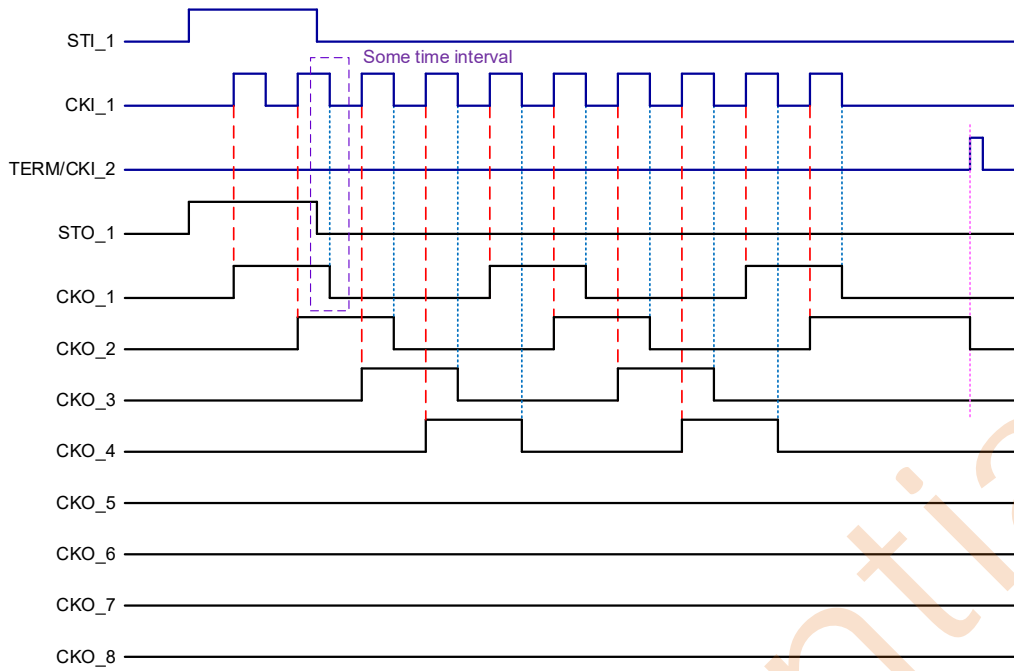

**SET1=Floating: 4 phase ; SET2=High: Some time**

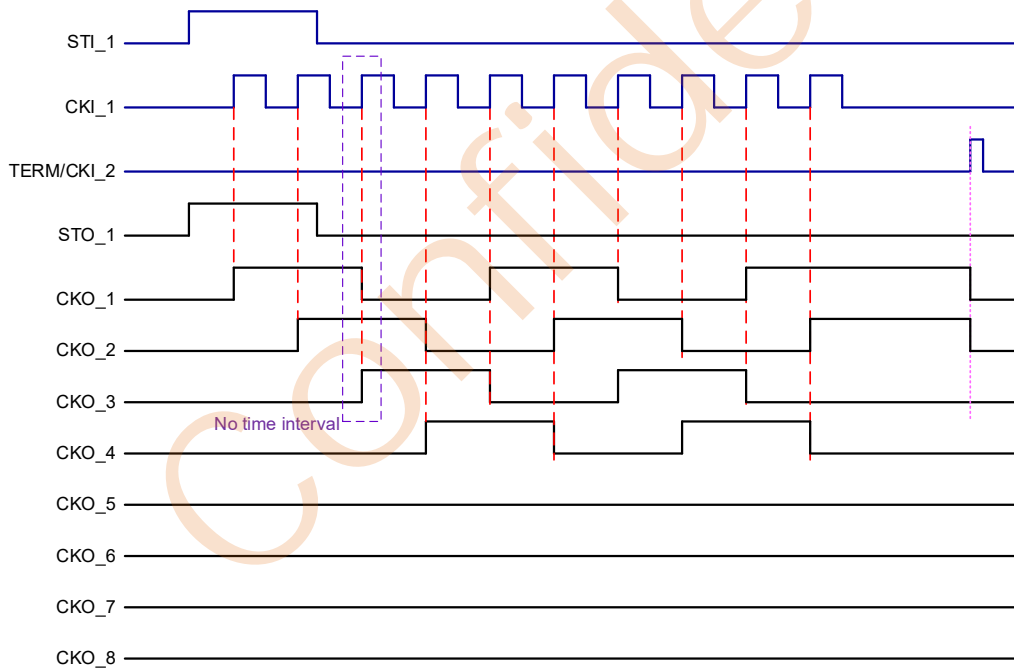

**SET1=Floating: 4 phase ; SET2=Low: No time**

## SET3/ Input Control Mode:

SET3 pin is to set 1 in clock control CKO or 2 in clock control CKO

PIN	Status	Level Shifter output
SET3	High/Floating	2 in clock control
	Low	1 in clock control

LP6274QVF contains 1/2 clock input to generate 4/6/8 clock out mode. When SET3<0.6V, clock input mode = 1 input control mode. Please reference follows waveform:

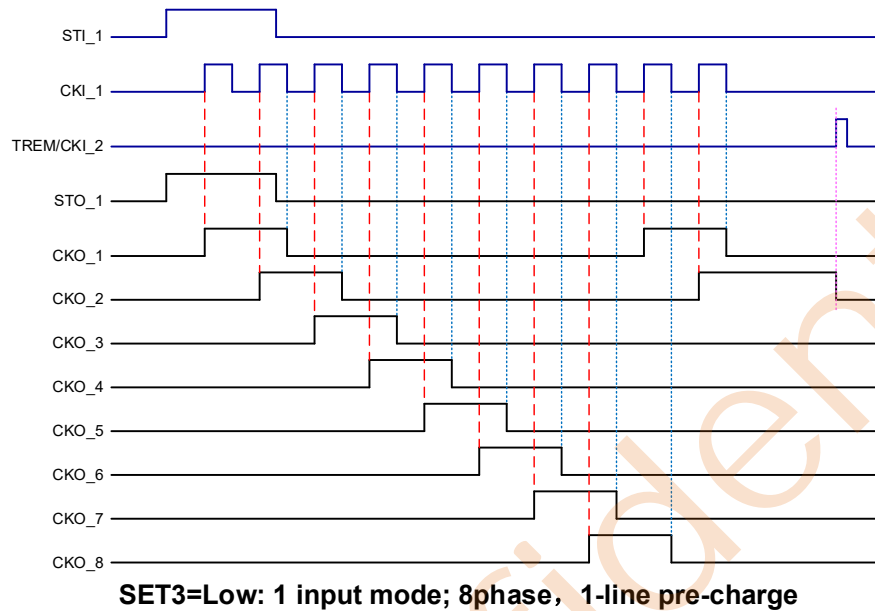

When SET3>1.5V, clock input mode = 2 input control mode. Then Terminate input pin is used to be TERM/CKI\_2 for 2 input mode function. Please reference follows waveform:

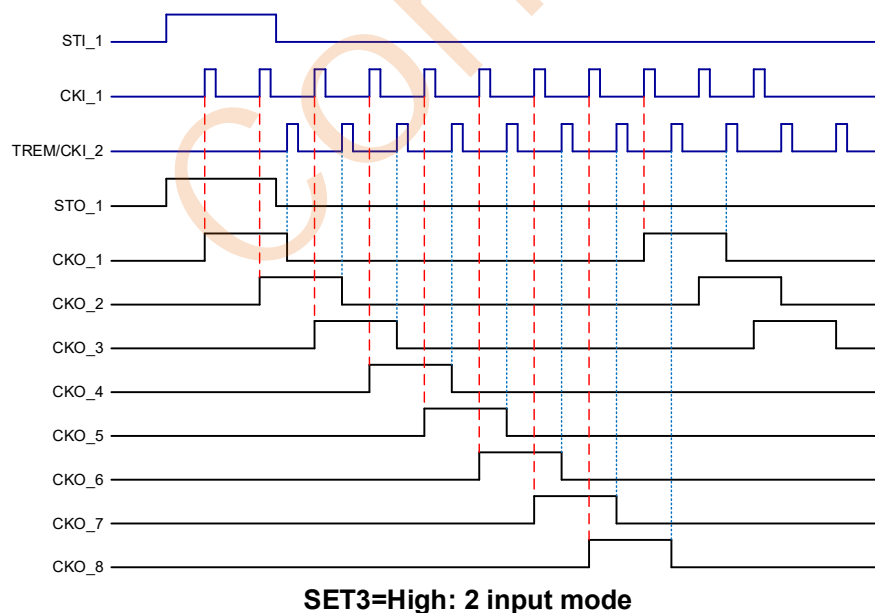

## MODE1:

MODE1 is the function of pre-charge type. Mode1 function is list below. Pre-charge setting only SET3=Low.

PIN	Logic Level	Logic Level	Logic Level	Logic Level	Logic Level	Logic Level	Logic Level	Logic Level
MODE1	Extra-H	H	M	L	Extra-H	H	M	L
SET2	0	0	0	0	1	1	1	1
Function	3 line pre- No time	1 line pre- No time	No pre- No time	2 line pre- No time	3 line pre- some time	1 line pre- some time	No pre- some time	2 line pre- some time

MODE1 = Middle level (No pre-charge); SET2 = Low/Floating (No time) CKO\_s = 8 phase

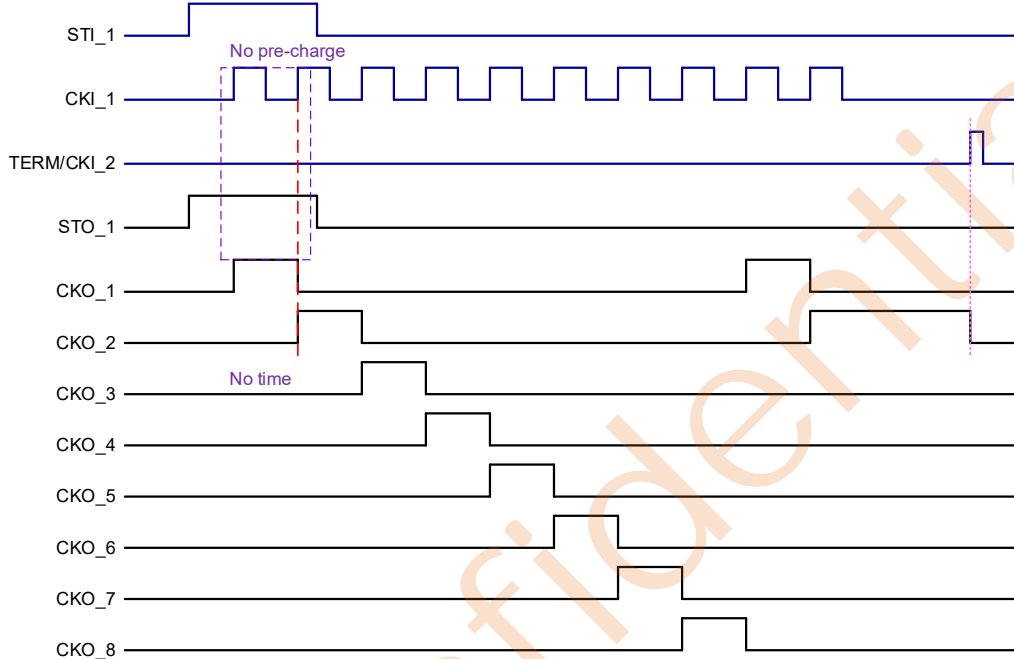

MODE1 = High level (1 pre-charge); SET2 = Low/Floating (No time) CKO\_s = 8 phase

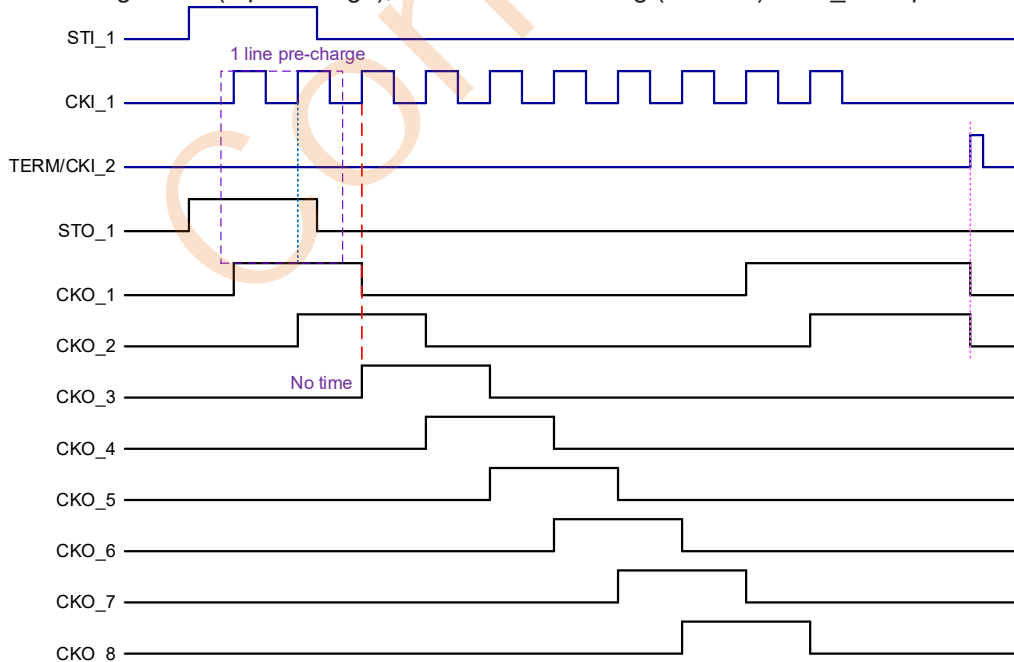

MODE1 = Low level (2 pre-charge); SET2 = Low/Floating (No time) CKO\_s = 8 phase

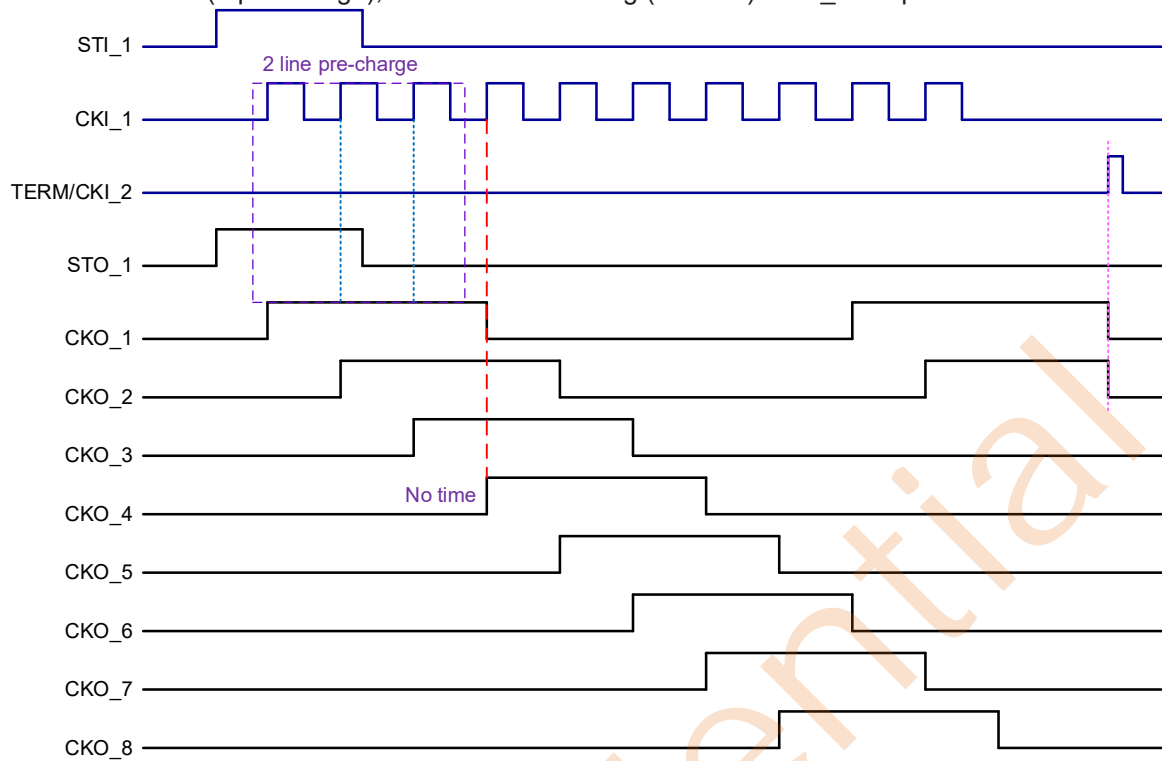

MODE1 = Extra High level (3 pre-charge); SET2 = Low/Floating (No time) CKO\_s = 8 phase

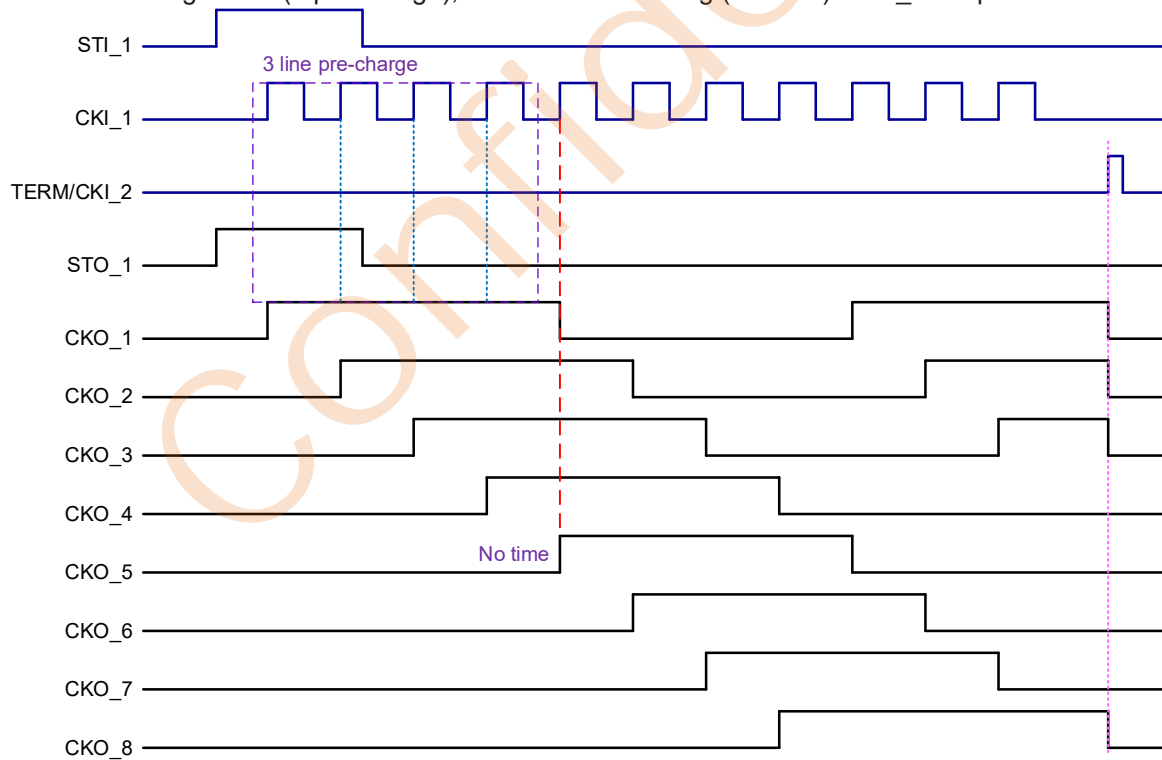

MODE1 = Middle level (No pre-charge); SET2 = High (Some time) CKO\_s = 8 phase

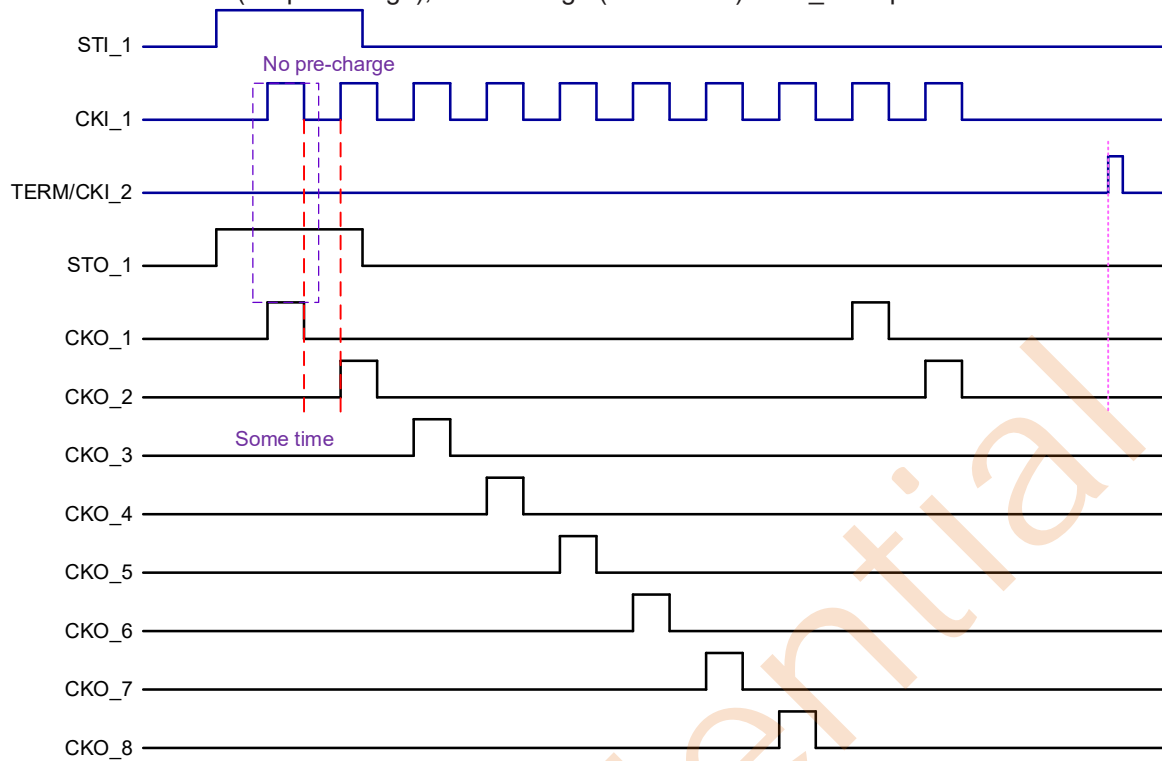

MODE1 = High level (1 line pre-charge); SET2 = High (Some time) CKO\_s = 8 phase

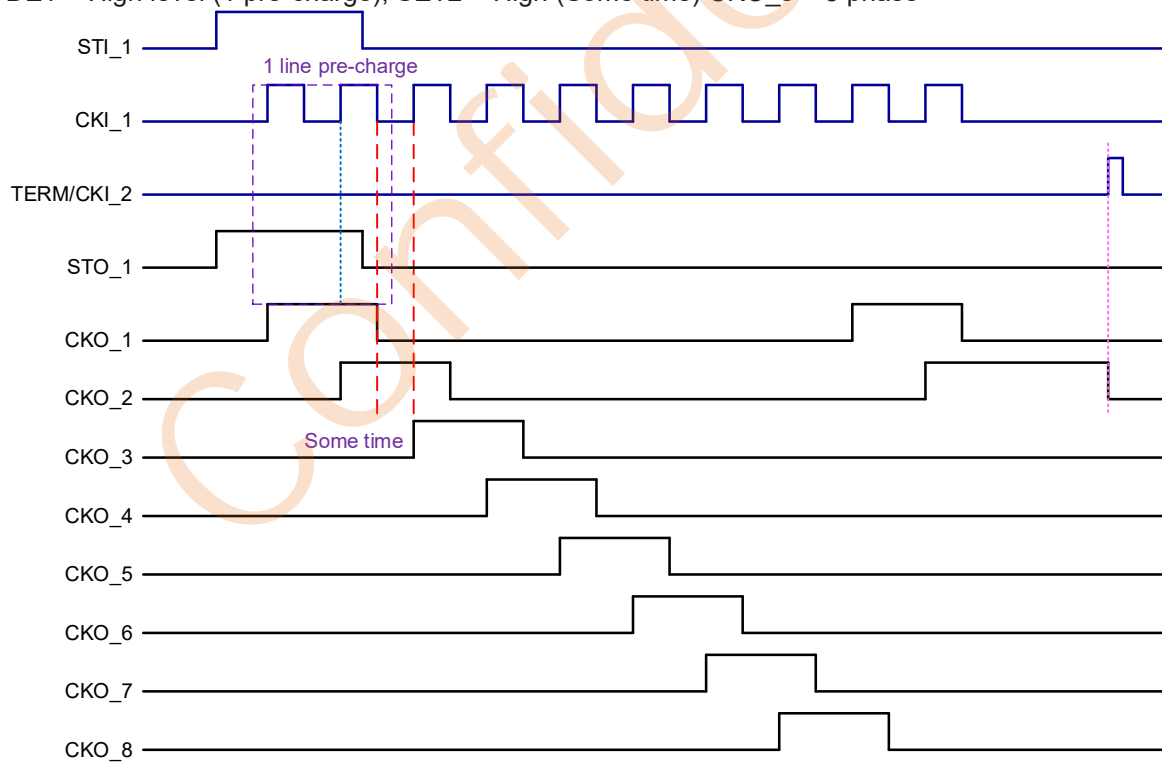

MODE1 = Low level (2 pre-charge); SET2 = High (Some time) CKO\_s = 8 phase

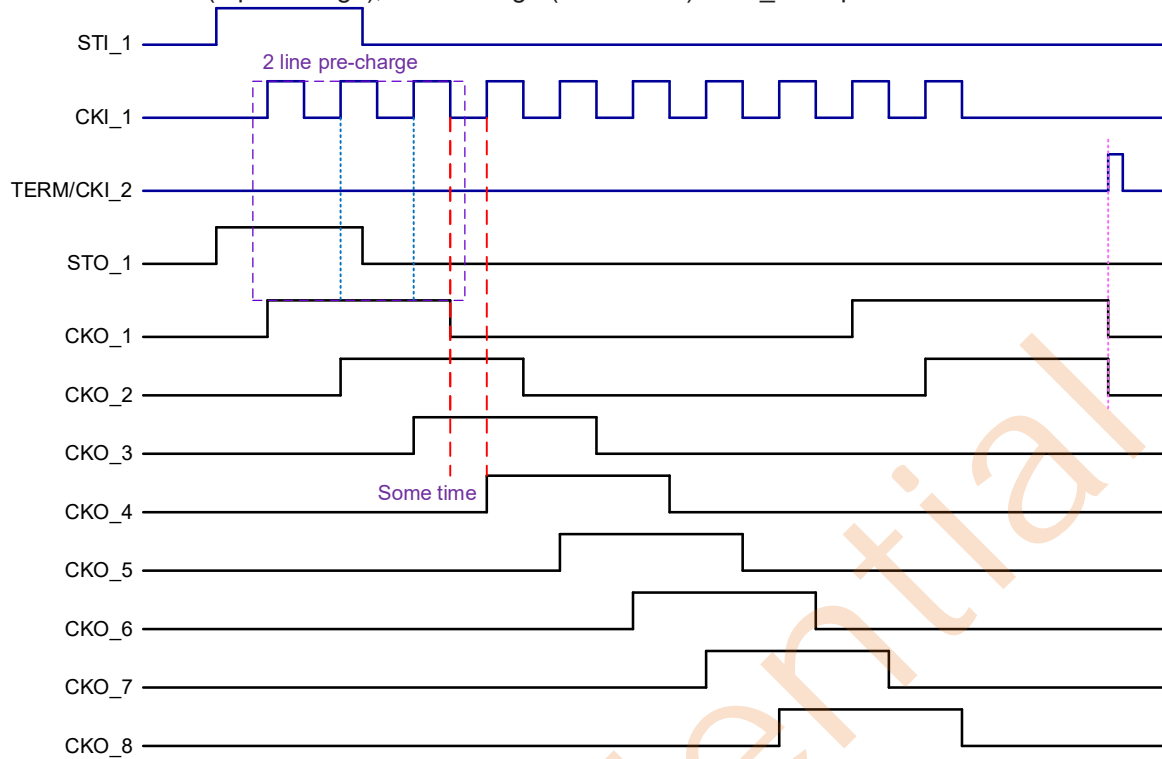

MODE1 = Extra High level (3 pre-charge); SET2 = High (Some time) CKO\_s = 8 phase

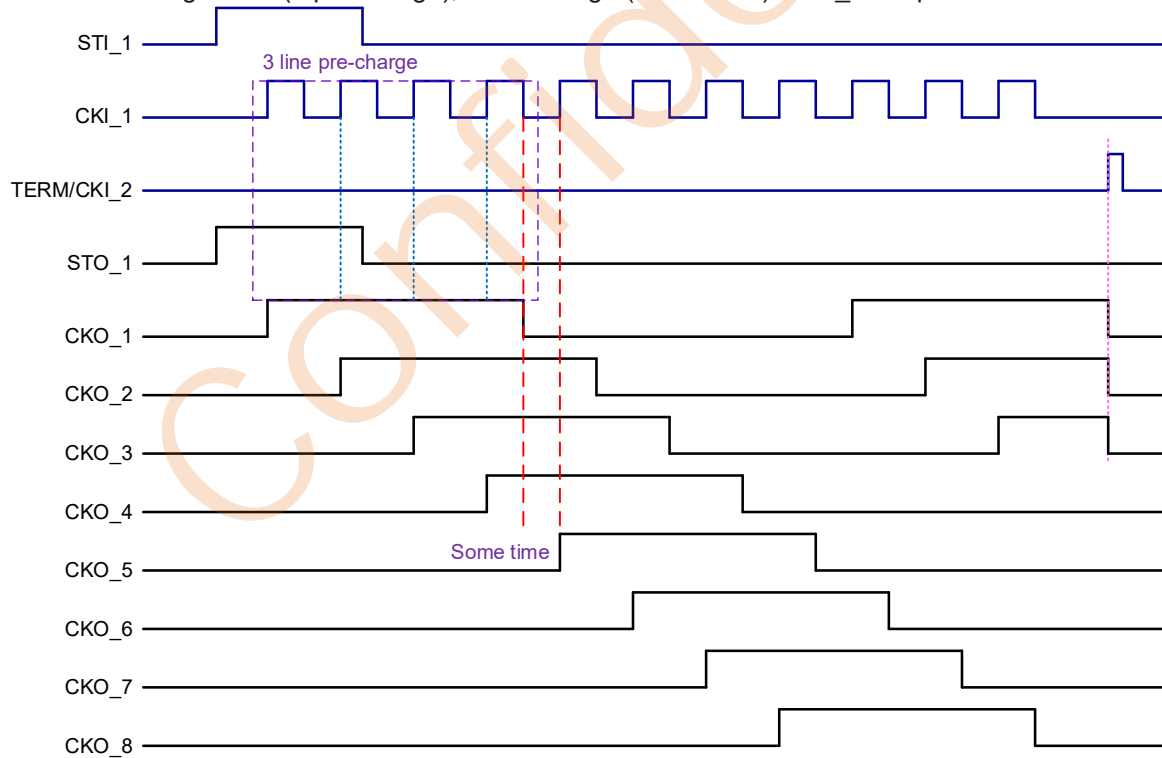



MODE1 = Middle level (No pre-charge); SET2 = Low/Floating (No time) CKO\_s = 6 phase

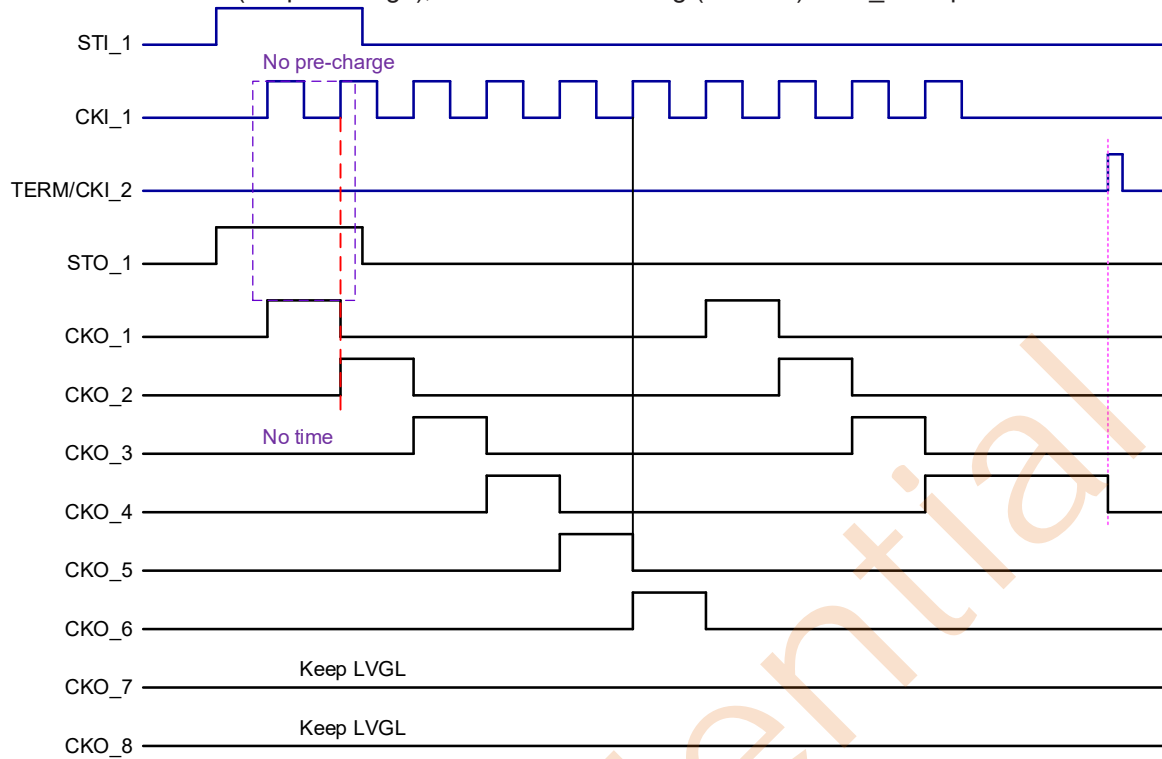

MODE1 = High level (1 pre-charge); SET2 = Low/Floating (No time) CKO\_s = 6 phase

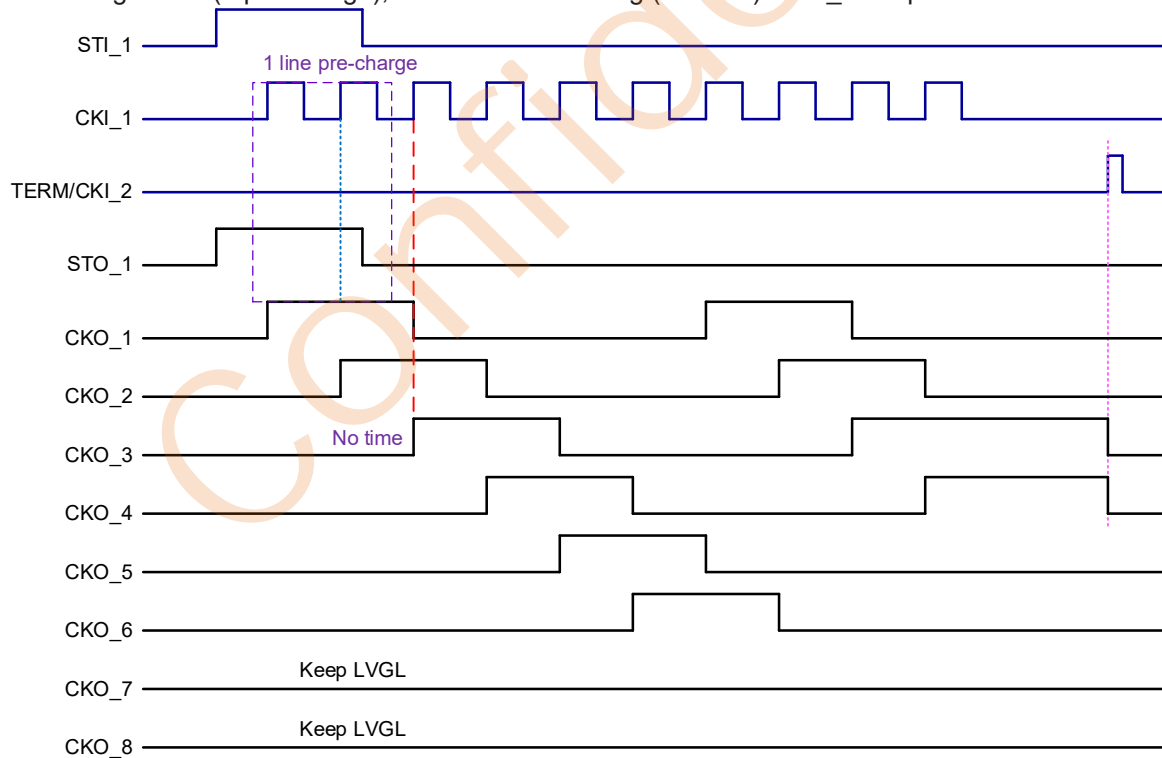

MODE1 = Low level (2 pre-charge); SET2 = Low/Floating (No time) CKO\_s = 6 phase

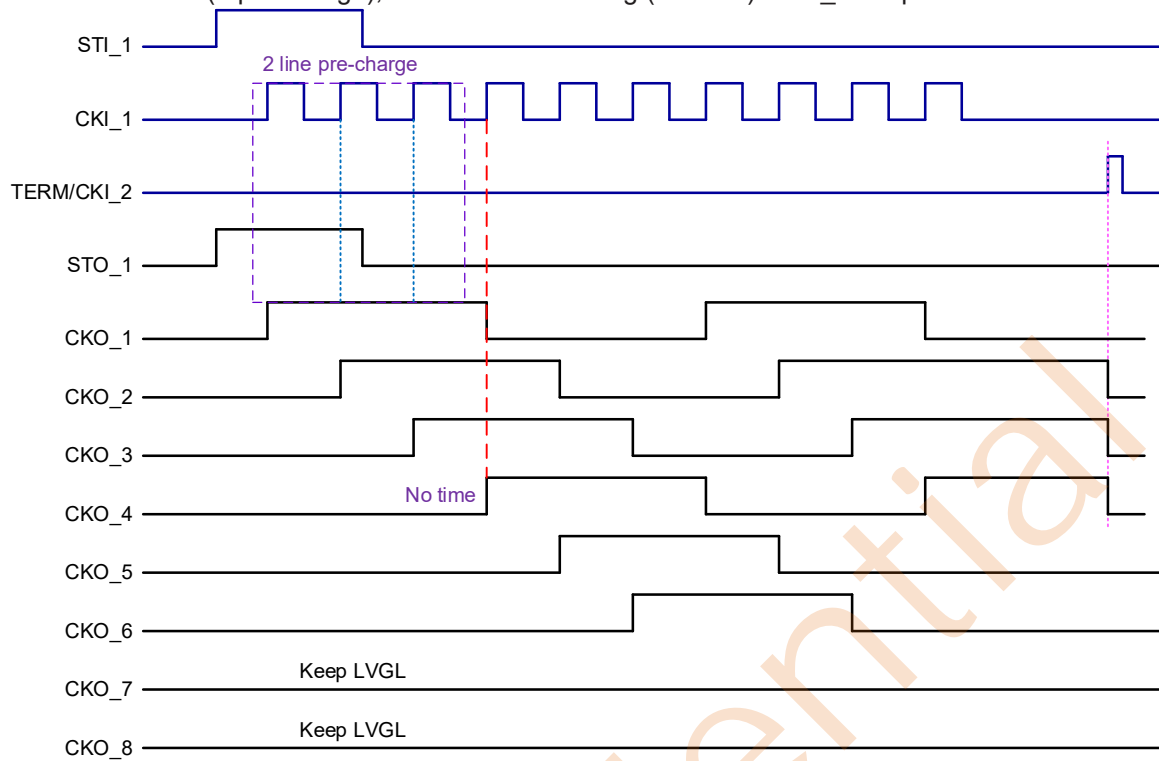

MODE1 = Extra High level (3 pre-charge); SET2 = Low/Floating (No time) CKO\_s = 6 phase

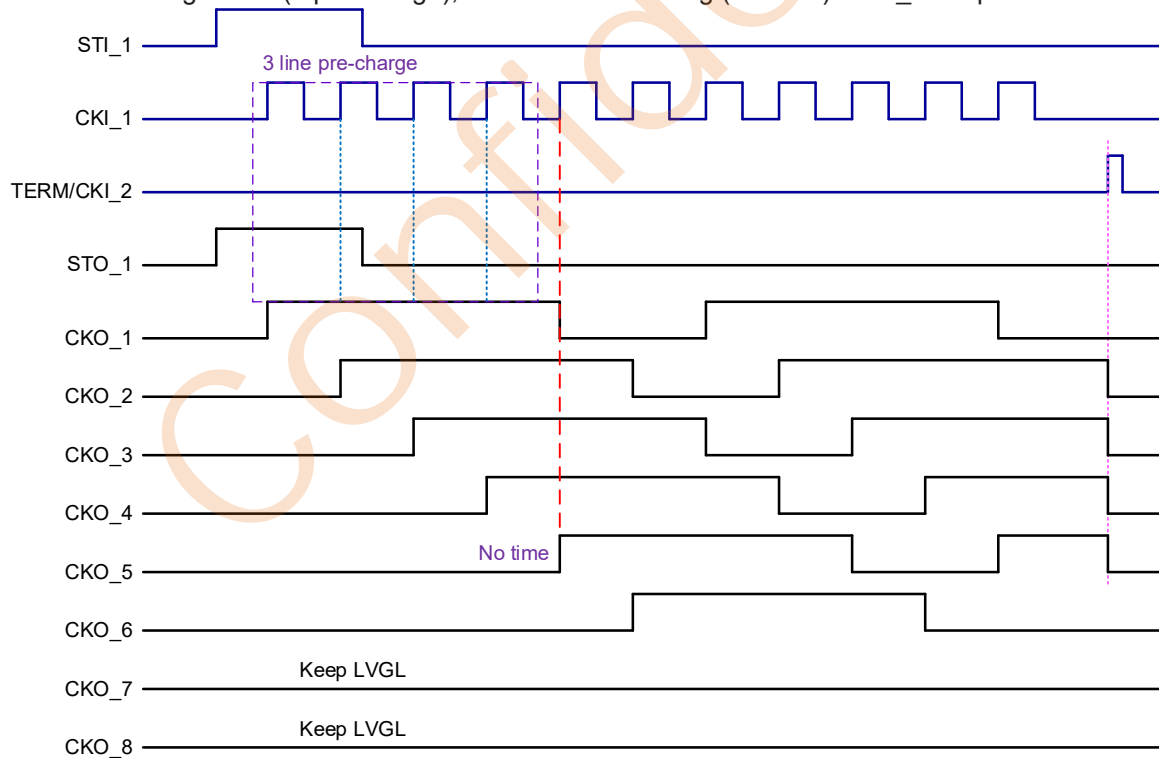



MODE1 = Middle level (No pre-charge); SET2 = High (Some time) CKO\_s = 6 phase

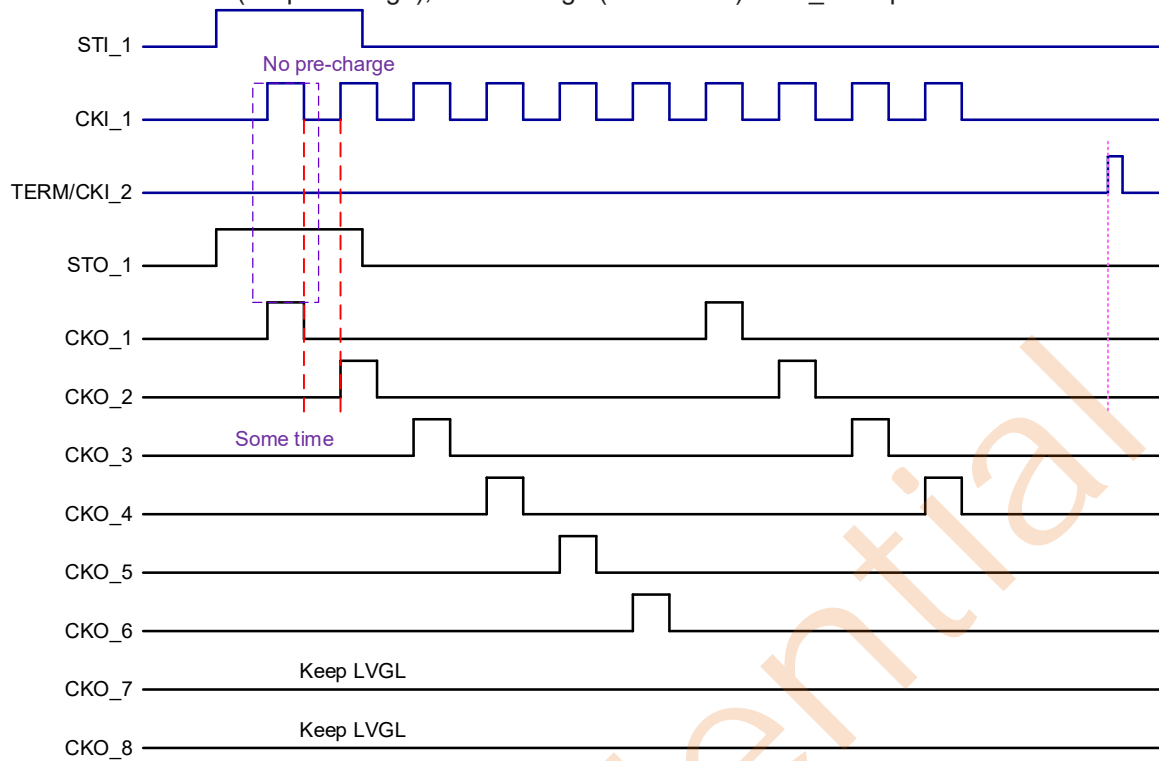

MODE1 = High level (1 line pre-charge); SET2 = High (Some time) CKO\_s = 6 phase

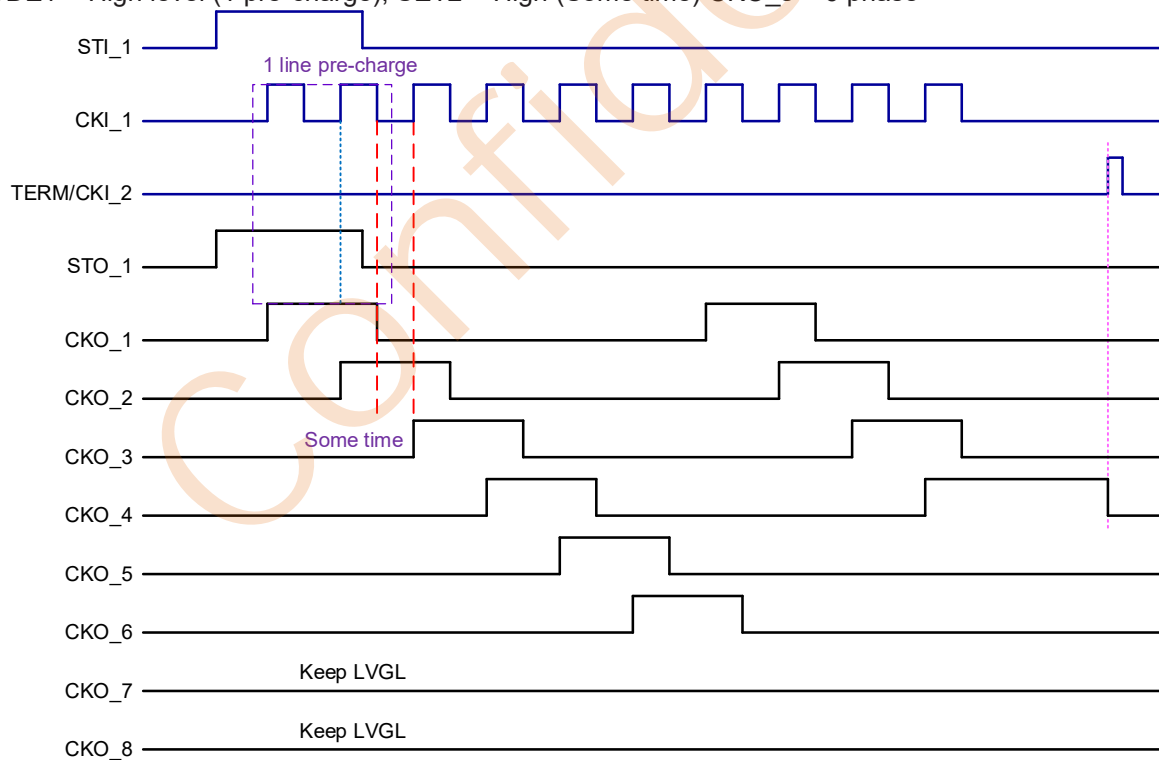

MODE1 = Low level (2 pre-charge); SET2 = High (Some time) CKO\_s = 6 phase

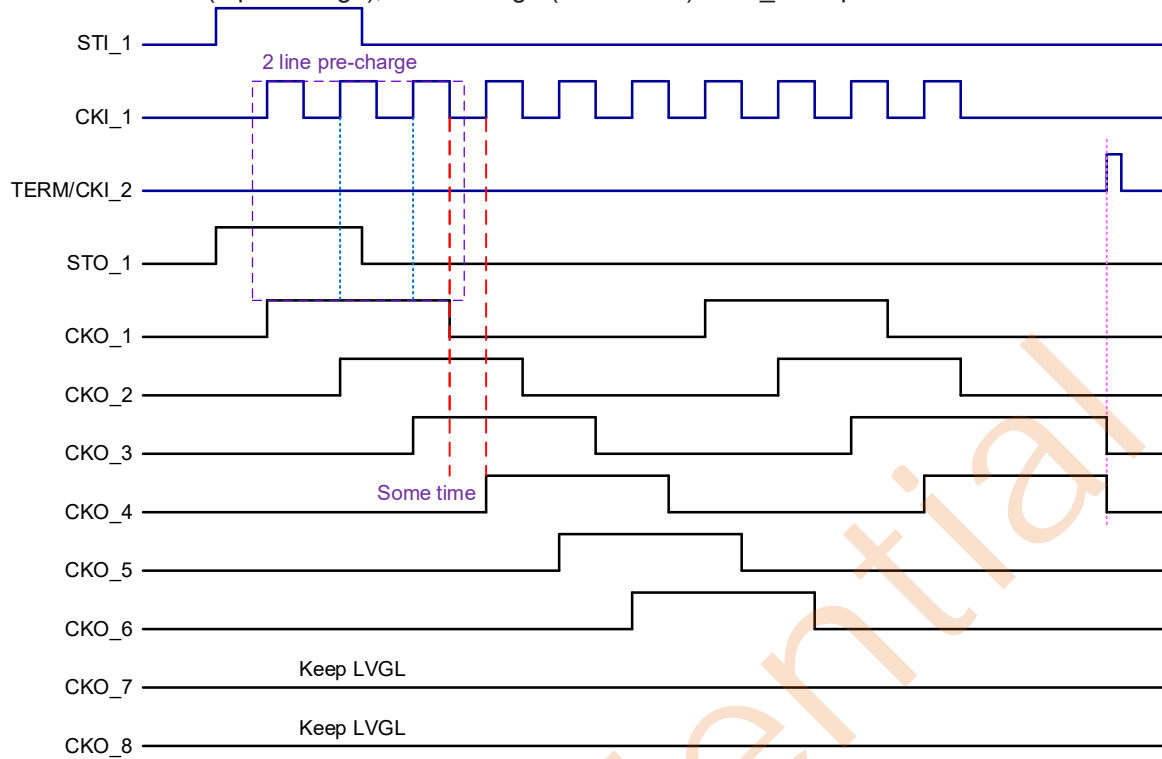

MODE1 = Extra High level (3 pre-charge); SET2 = High (Some time) CKO\_s = 6 phase

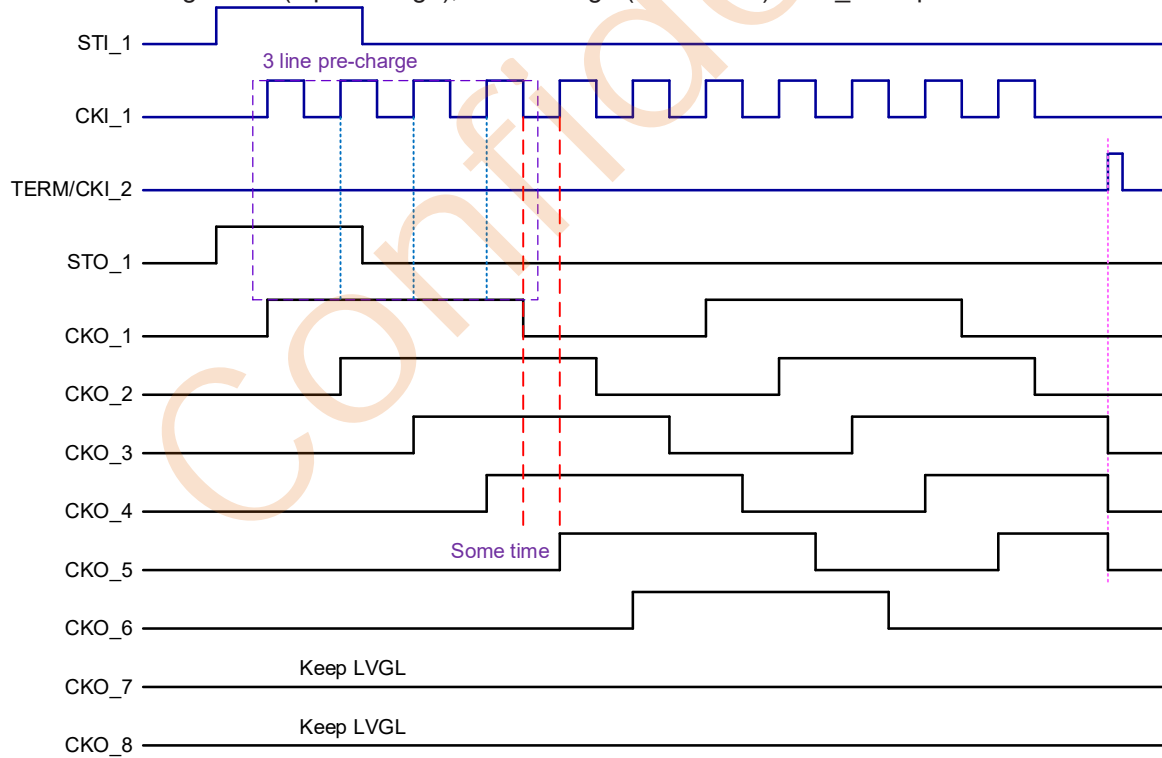



MODE1 = Middle level (No pre-charge); SET2 = Low/Floating (No time) CKO\_s = 4 phase

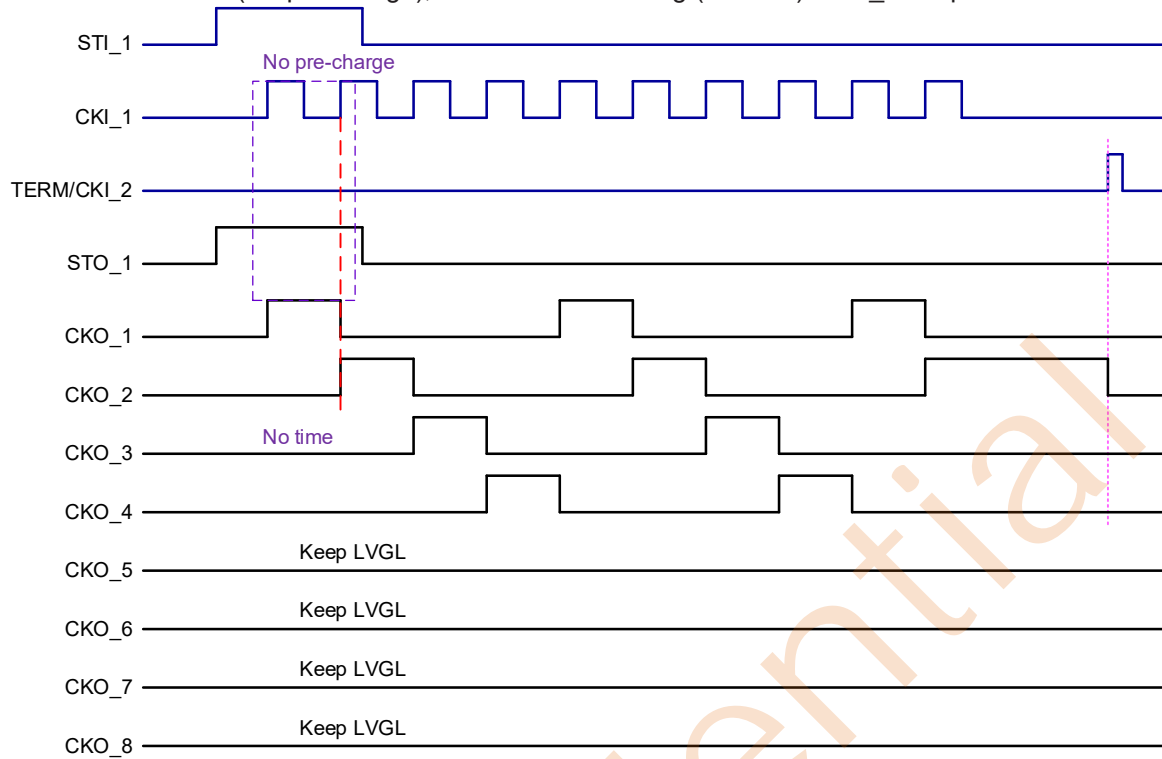

MODE1 = High level (1 pre-charge); SET2 = Low/Floating (No time) CKO\_s = 4 phase

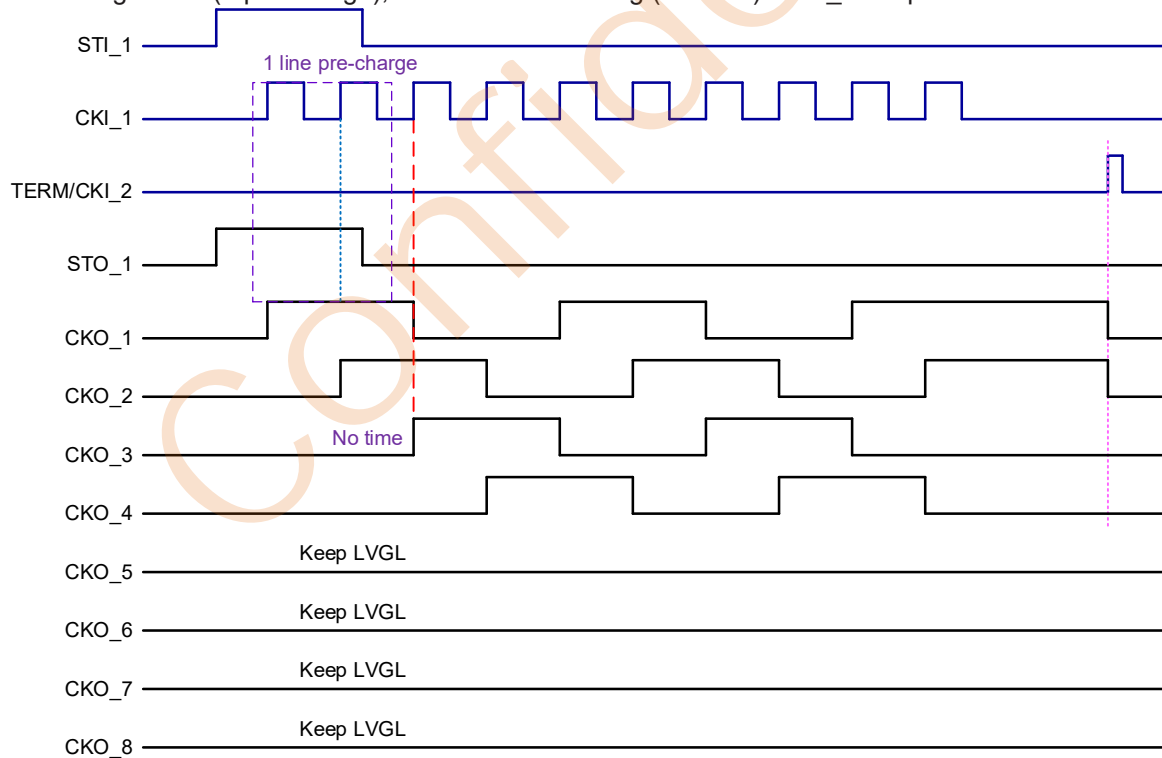



MODE1 = Low level (2 pre-charge); SET2 = Low/Floating (No time) CKO\_s = 4 phase

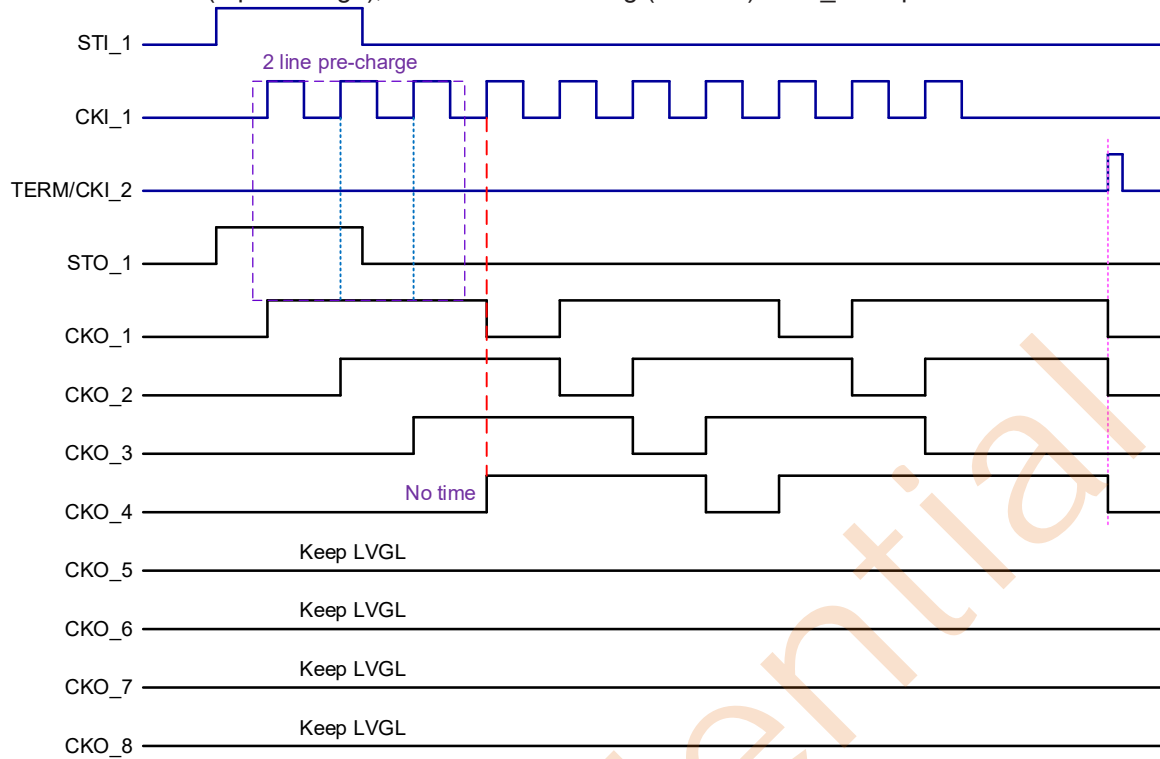

MODE1 = Extra High level (3 pre-charge); SET2 = Low/Floating (No time) CKO\_s = 4 phase

**Invalid setting (All CKO output always pull low LVGL)**

Confidential

MODE1 = Middle level (No pre-charge); SET2 = High (Some time) CKO\_s = 4 phase

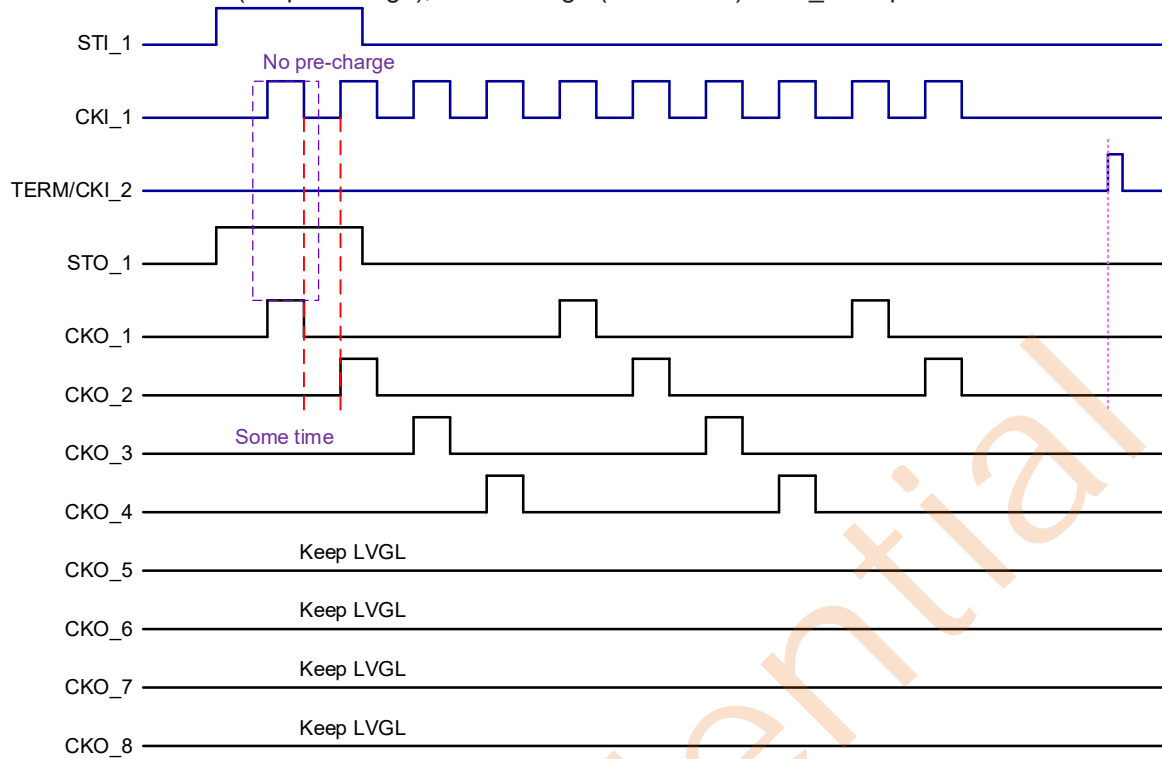

MODE1 = High level (1 pre-charge); SET2 = High (Some time) CKO\_s = 4 phase

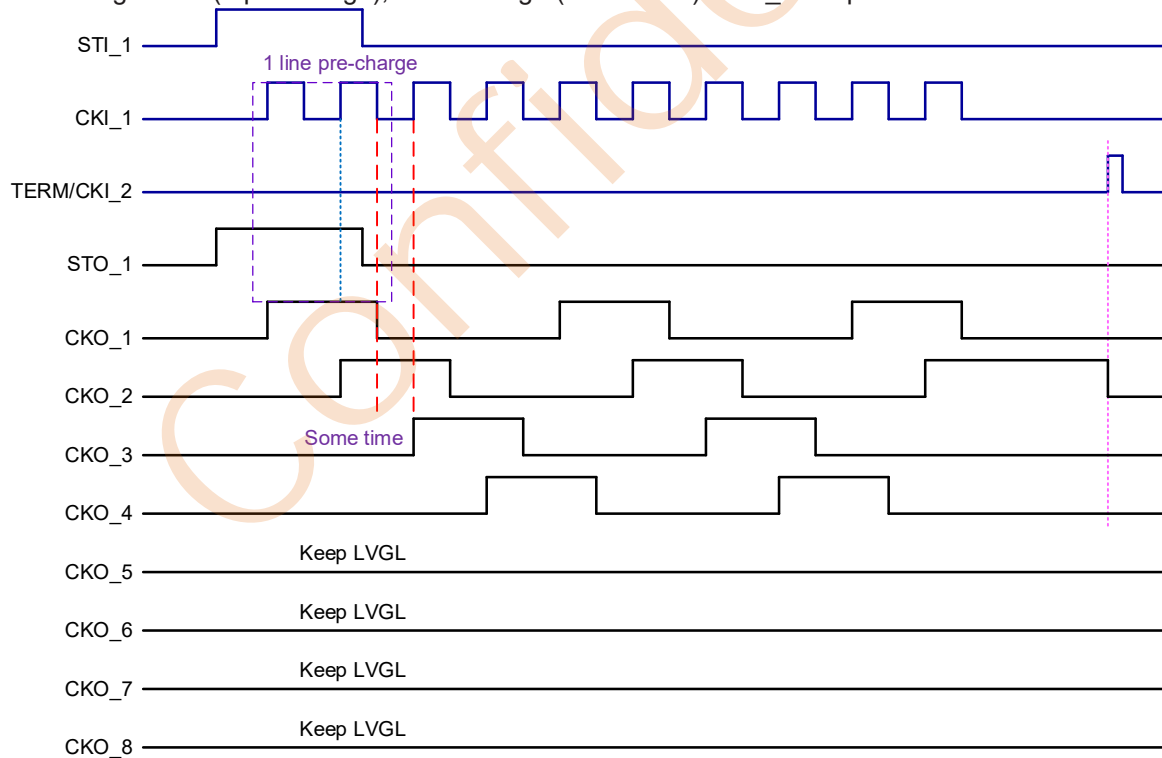

MODE1 = Low level (2 pre-charge); SET2 = High (Some time) CKO\_s = 4 phase

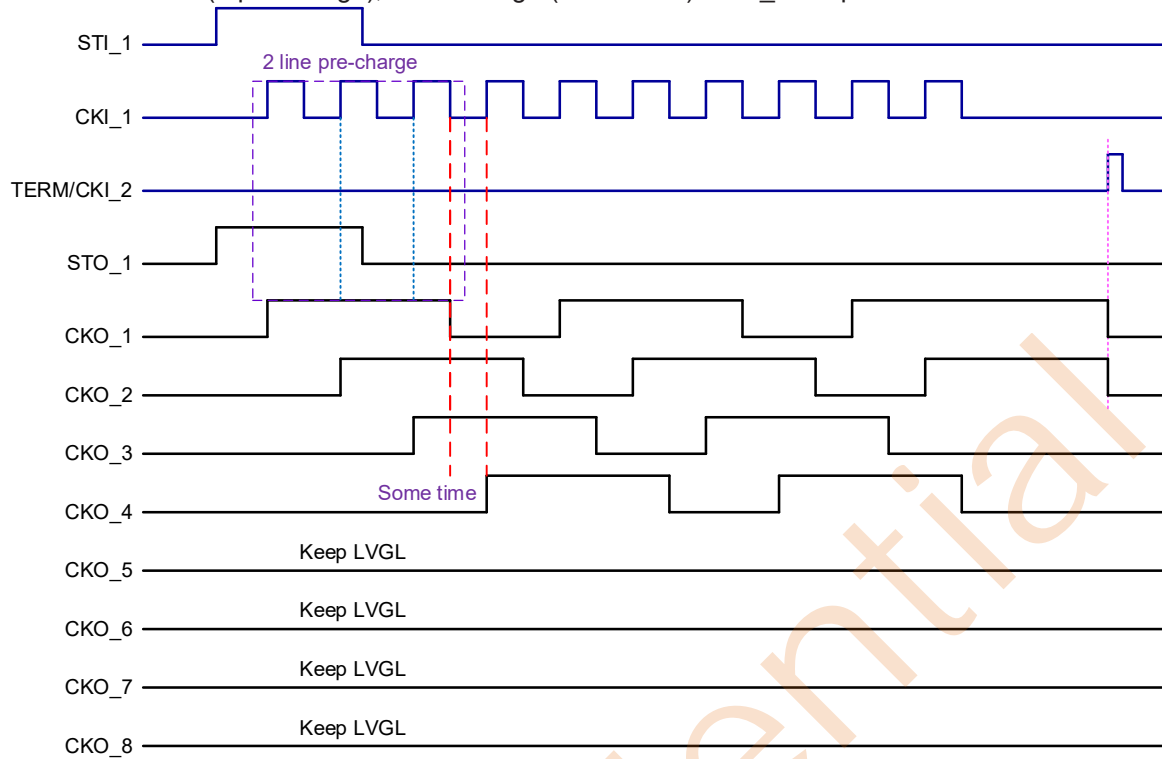

MODE1 = Extra High level (3 pre-charge); SET2 = High (Some time) CKO\_s = 4 phase

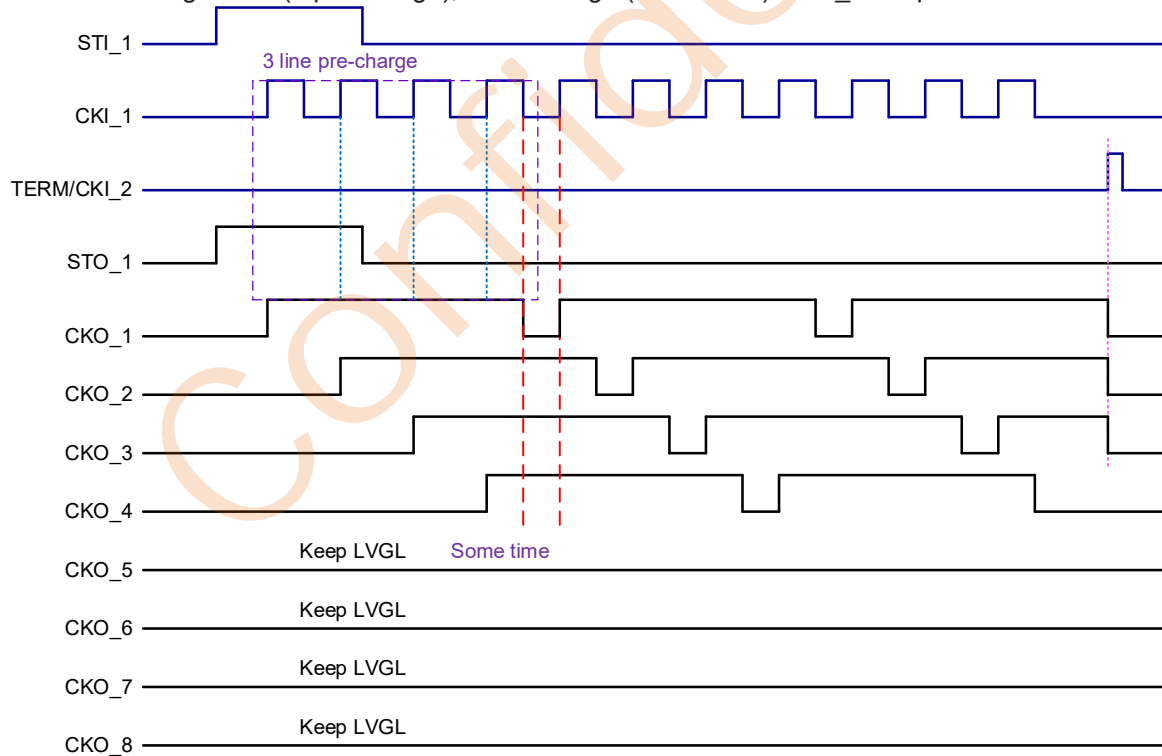

## MODE2:

MODE2 is to set the CKO\_s 1 line on mode output or 2 line on mode output

When Mode2 input signal level (L -> H or H -> L) change, the HCs will not change until next STI\_1 rising edge. After that, LP6274QVF will mask output 2 frames (only STO\_1, HC1~8 pull to VGL).

PIN	Status	Level Shifter output
MODE2	High level	CKO_s is 2-line on mode. CKO_1=CKO_2, CKO_3=CKO_4 CKO_5=CKO_6, CKO_7=CKO_8
	Low/Floating	CKO_s is 1-line on mode. CKO_1~8 sequentially from CKO_1~8

MODE2 = Low/Floating; 1 line on mode

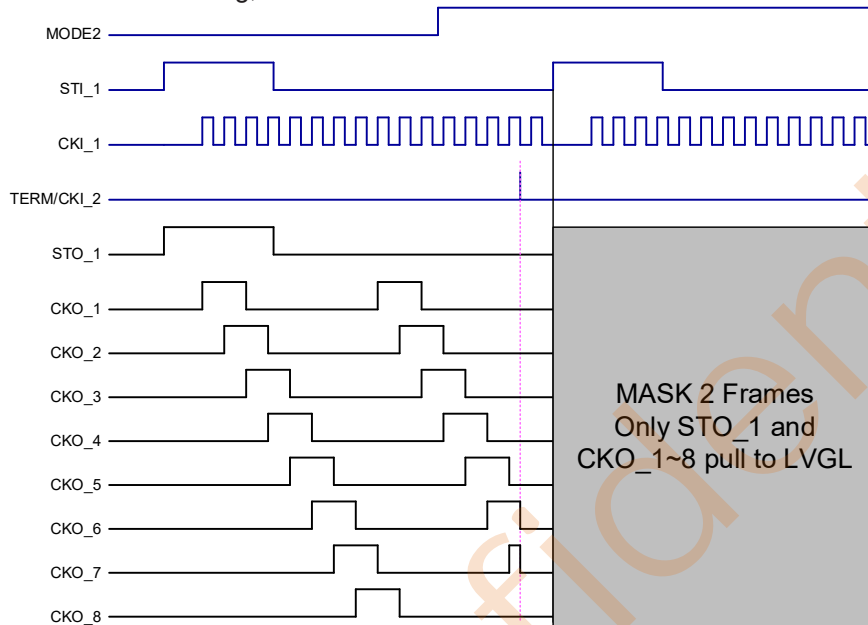

MODE2 = High; 2 line on mode

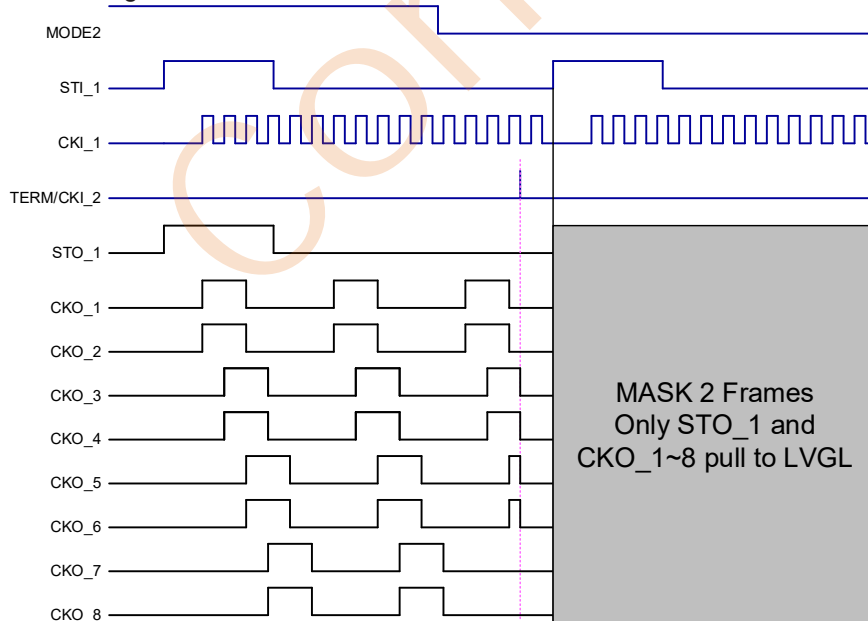

### MODE2:

MODE2 is to set the CKO\_s 1 line on mode output or 2 line on mode output

When Mode2 input signal level (L -> H or H -> L) change, the HCs will not change until next STI\_1 rising edge. After that, LP6274QVF will mask output 2 frames (only STO\_1, CKO\_1~8 pull to LVGL).

PIN	Status	Level Shifter output
MODE2	High level	CKO_s is 2-line on mode. CKO_1=CKO_2, CKO_3=CKO_4 CKO_5=CKO_6, CKO_7=CKO_8
	Low/Floating	CKO_s is 1-line on mode. CKO_1~8 sequentially from CKO_1~8

MODE2 = Low/Floating; 1 line on mode

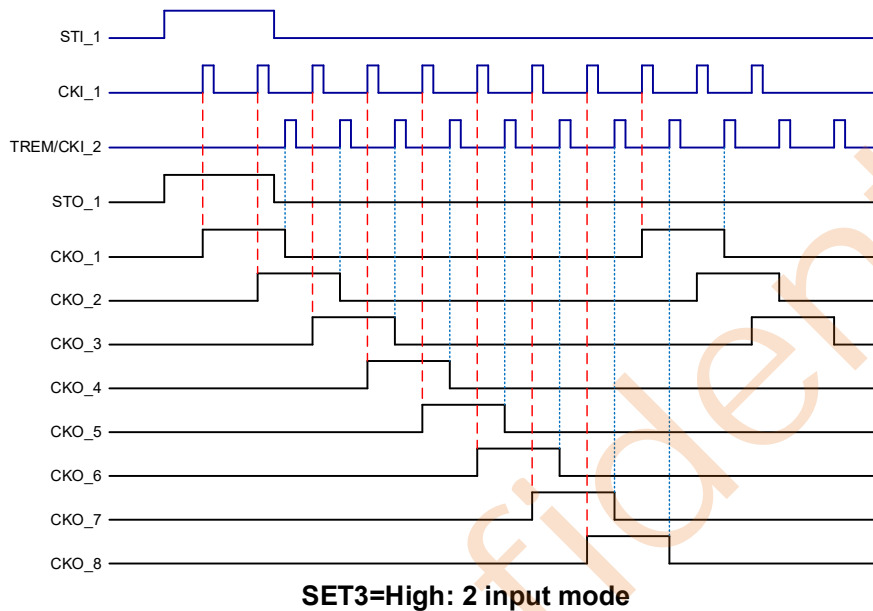

MODE2 = High; 2 line on mode

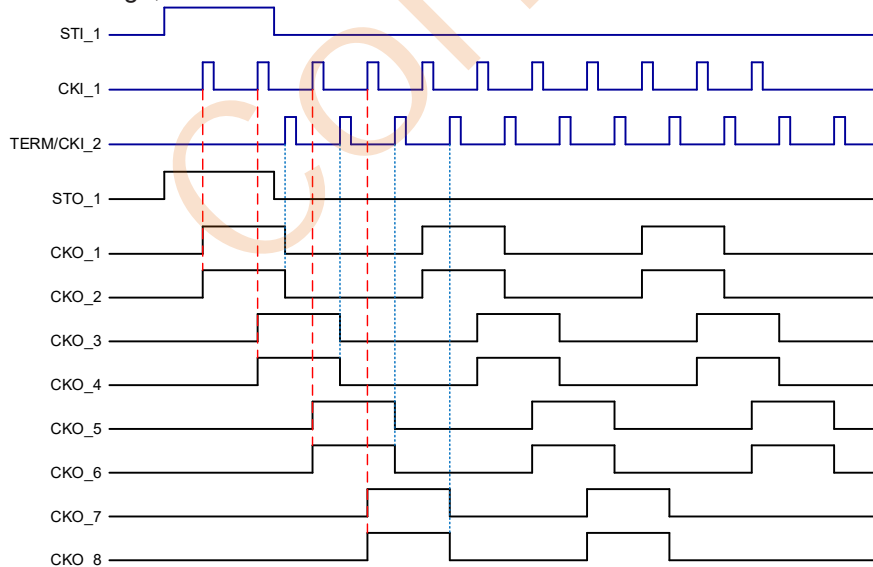

## DISA\_DSTO:

DISA\_DSTO function is list below:

PIN	Status	Level Shifter output
DISA_DSTO	High level	STO_1 ON, (follow STI_1) STO_2 keep in LVGL
	Low/Floating	STO_1 ON, (follow STI_1) STO_2 ON, (follow STI_2)

DISA\_DSTO = High, STO\_2 keep in VGL

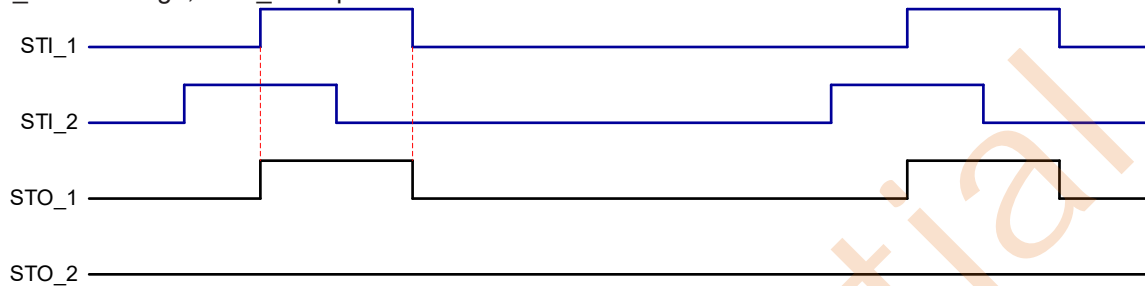

DISA\_DSTO = Low/Floating, STO\_2 follow STI\_2

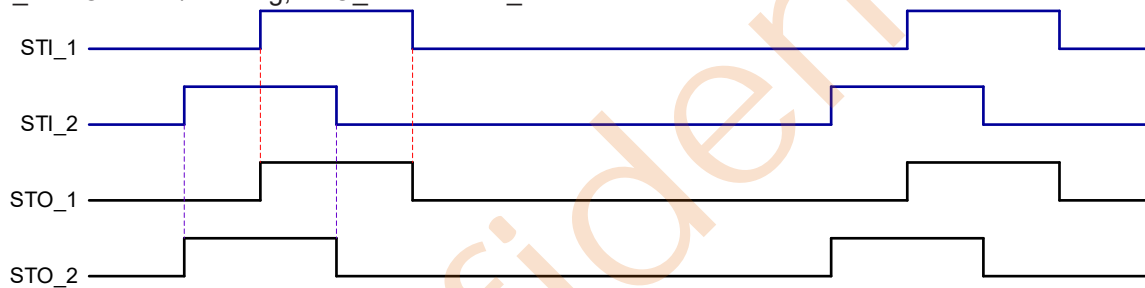

Confidential

## CKI\_1 stop protection(CKISP)

The LP6274QVF can generate an internal terminate signal to pull CKO\_1~8 output to negative voltage. Please follow reference flow chart. The priority of CKI\_1 stop protection is highest. If CKI\_1 stop protection is working, then the Multi-CKI protection is stopped.

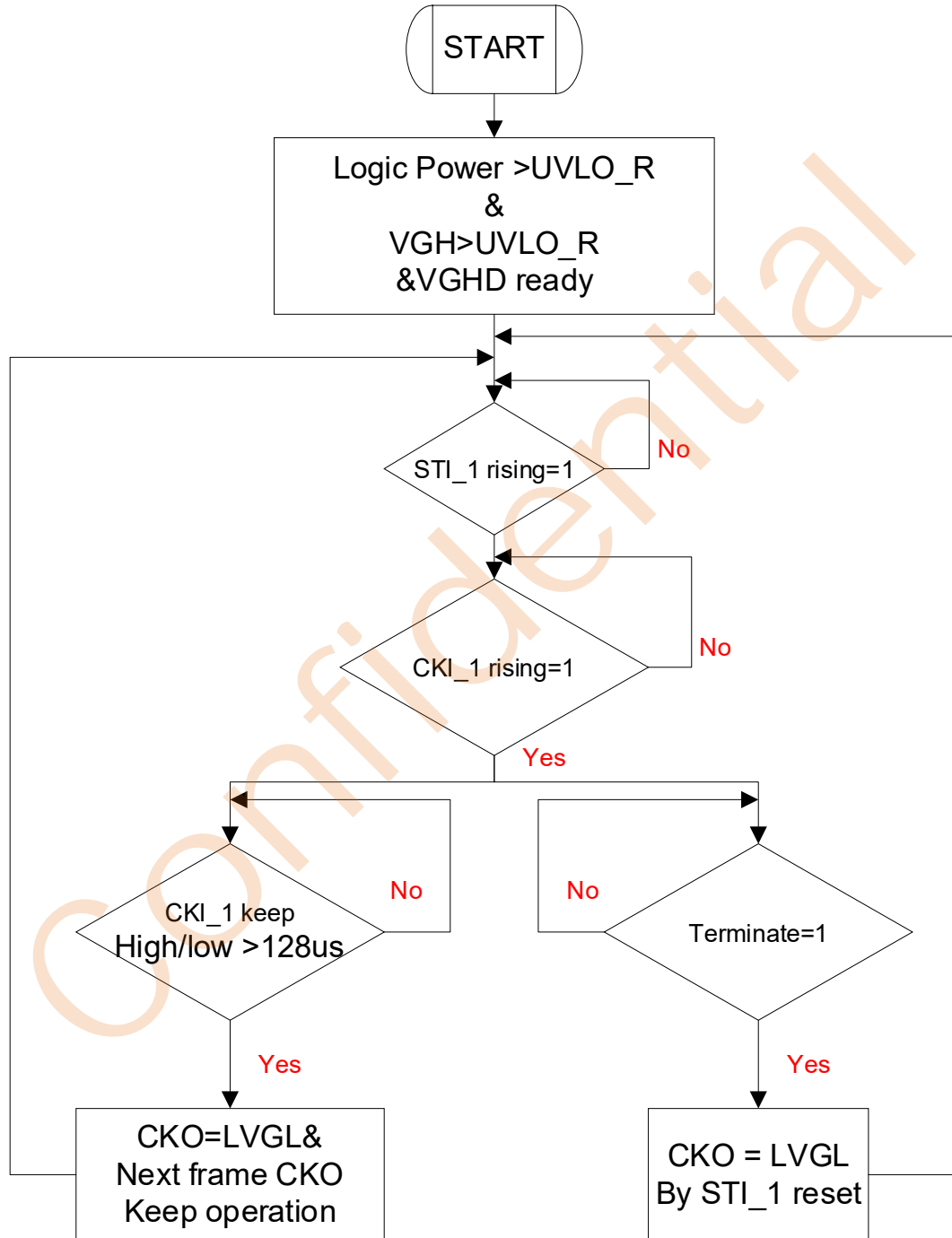

CKI\_1 stop protection flow chart

Case 1: CKI\_1 stop high/low (1 clock control CKO\_x output)

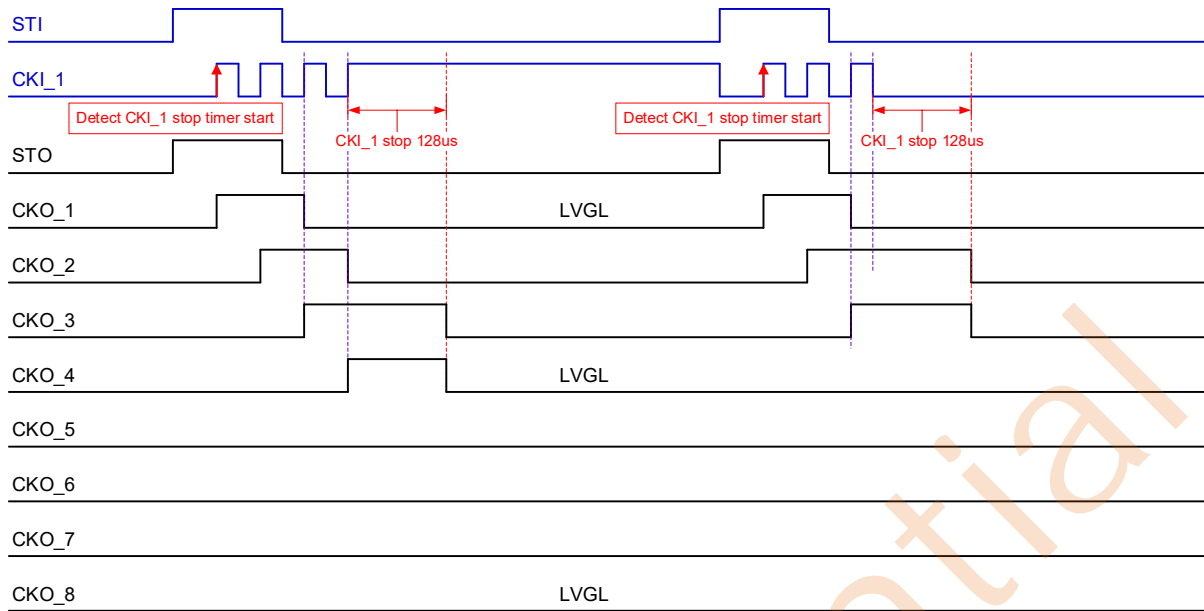

Case 2: CKI\_1 Blanking time (1 clock control CKO\_x output)

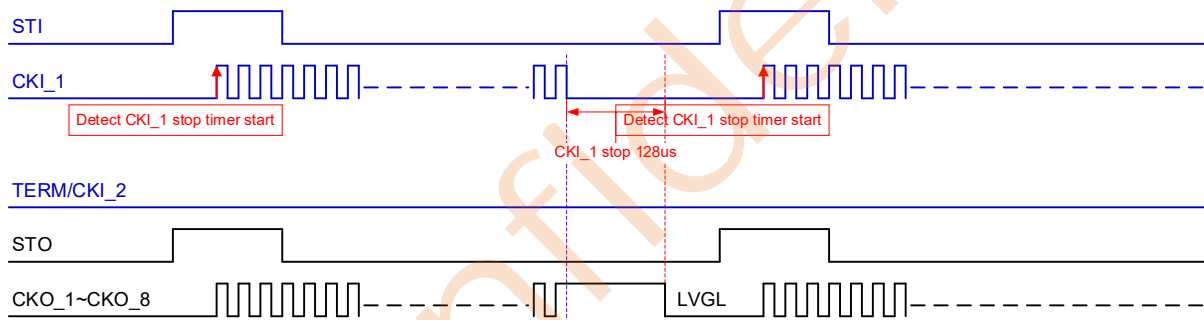

## Over Current Protection (OCP)

The LP6274QVF can detect output pins (STO\_1~2, CKO\_1~CKO\_8, LC1~LC2, XON) short to each other short current. If the pin to pin short current over limit, the IC all outputs will pull high impedance state. After VIN\_UVLO, IC recovers again. Please follow reference flow chart. If continue 32 times ST have short occur, IC will pull all outputs to high impedance state. After VIN\_UVLO, IC recovers again.

OCP Function is list below:

PIN	Status	Level Shifter output
OCP_EN	High	OCP Function Disable
	Floating	OCP Function Enable, Current limit = 60mA
	Low	OCP Function Enable, Current limit = 100mA

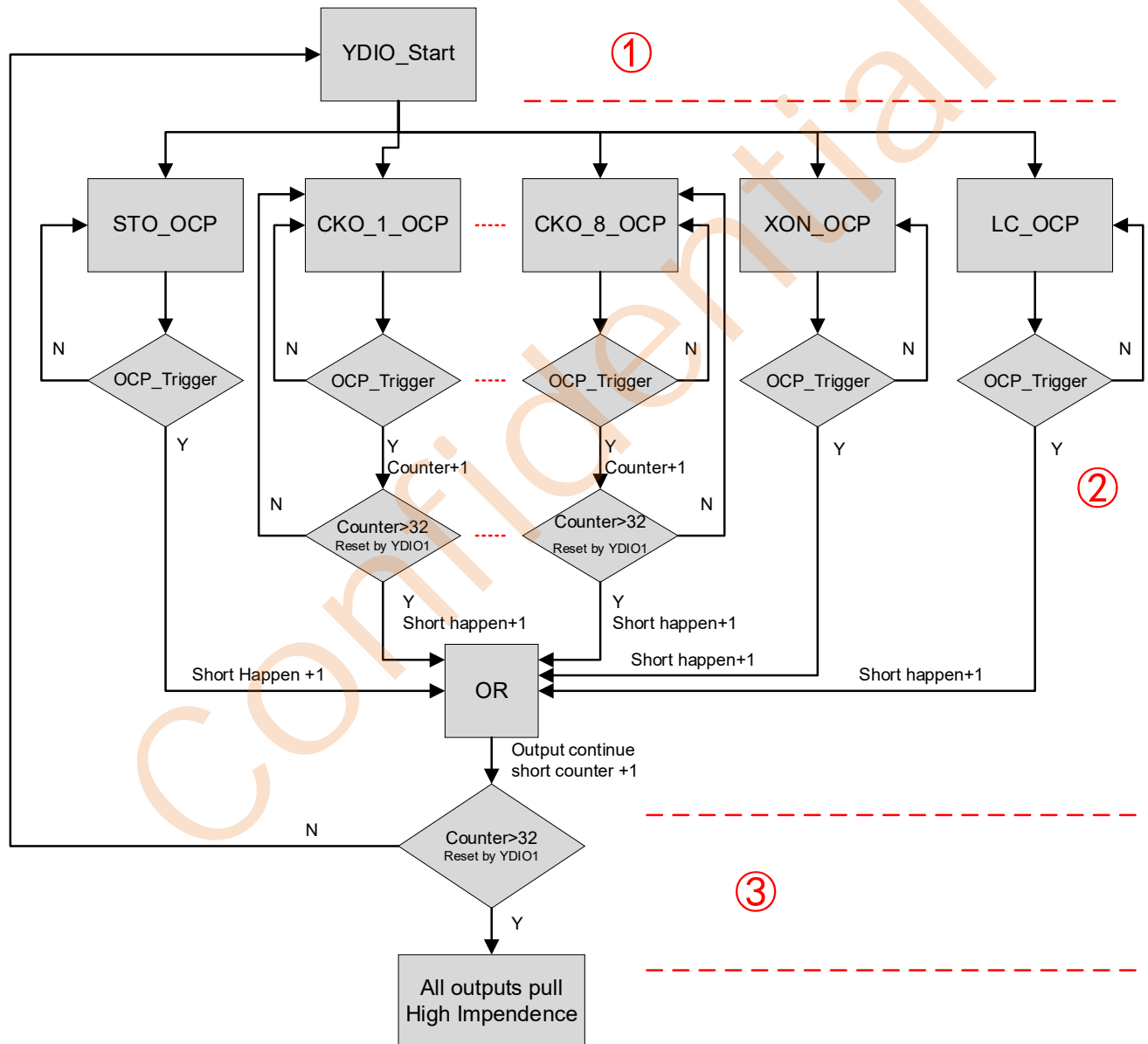

Over Current Protection flow chart

\*Each CKO channel need to count OCP trigger times with itself, until counter>32 then alarm short happen+1.

**STO:**

1. Blanking time: to avoid inrush current in this time period.
2. De\_noise time: to detect continue over current in this time period. Only continue over current time bigger than de\_noise time, and then trigger over current counter+1 per STO.
3. Detect over current level: follow OCP current level setting

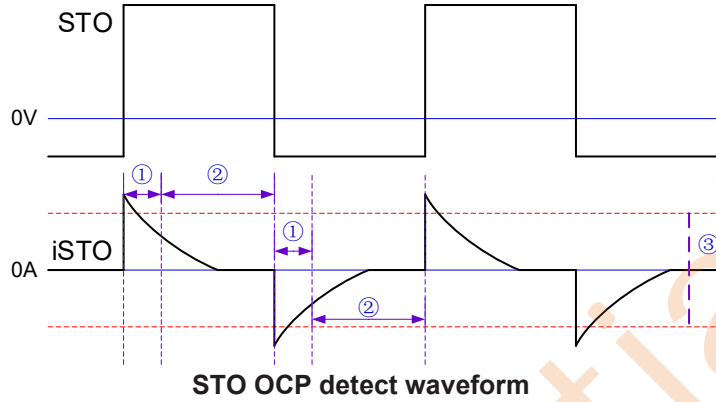

**CKO:**

1. Blanking time: to avoid inrush current in this time period.
2. De\_noise time: to detect continue over current in this time period. Only continue over current time bigger than de\_noise time, and then trigger over current counter+1 per STO.
3. Detect over current level: follow OCP current level setting

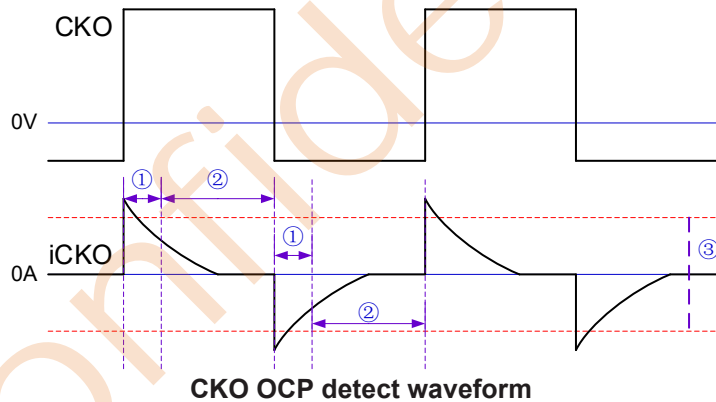

**LC:**

1. Blanking time: to avoid inrush current in this time period.
2. De\_noise time: to detect continue over current in this time period. Only continue over current time bigger than de\_noise time, and then trigger over current counter+1 per STO.
3. Detect over current level: follow OCP current level setting

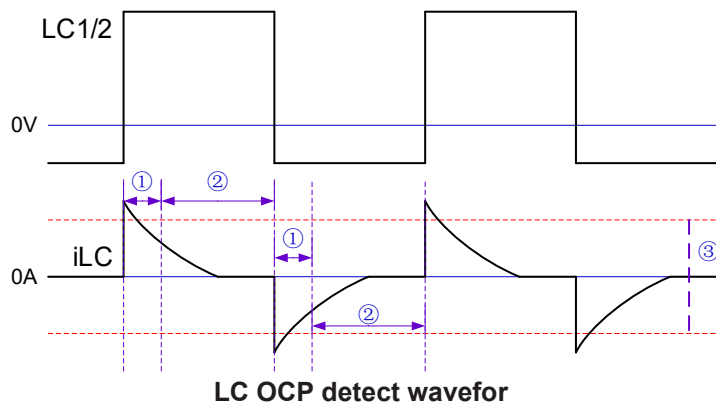

**XON:**

2. De\_noise time: to detect continue over current in this time period. Only continue over current time bigger than de\_noise time, and then trigger over current counter+1 per STO.
3. Detect over current level: follow OCP current level setting

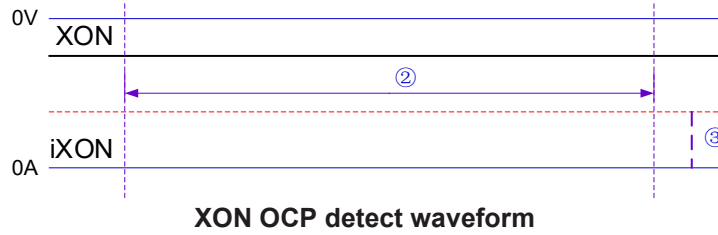

Confidential

## Short Current Protection (SCP)

The LP6274QVF can detect output pins (STO\_1~2, CKO\_1~CKO\_8, LC1~LC2, XON) short to each other short current. If the pin to pin short current over limit, the IC all outputs will pull high impedance state. After VIN\_UVLO, IC recovers again. If continue 3 times STI\_1 have short occur, IC will pull all outputs to high impedance state. After VIN\_UVLO, IC recovers again.

### CKO SCP case1:

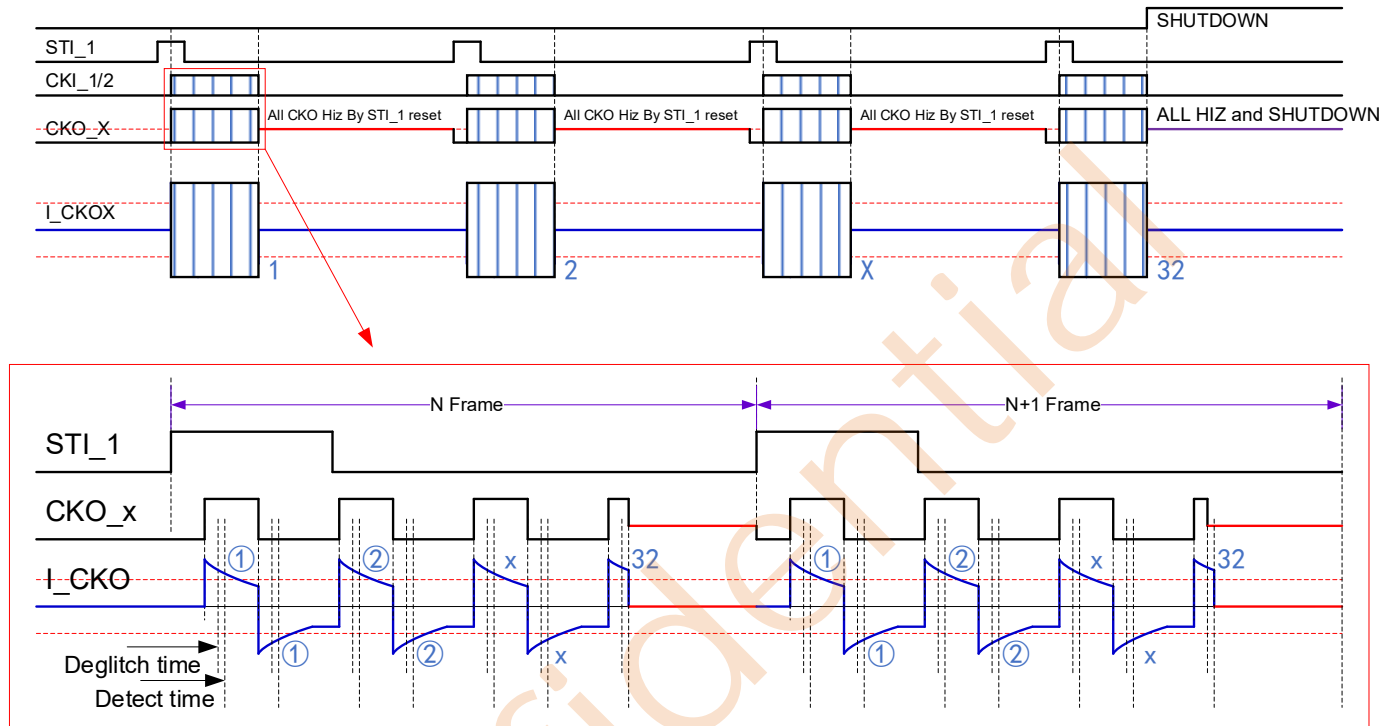

### CKO SCP case2:

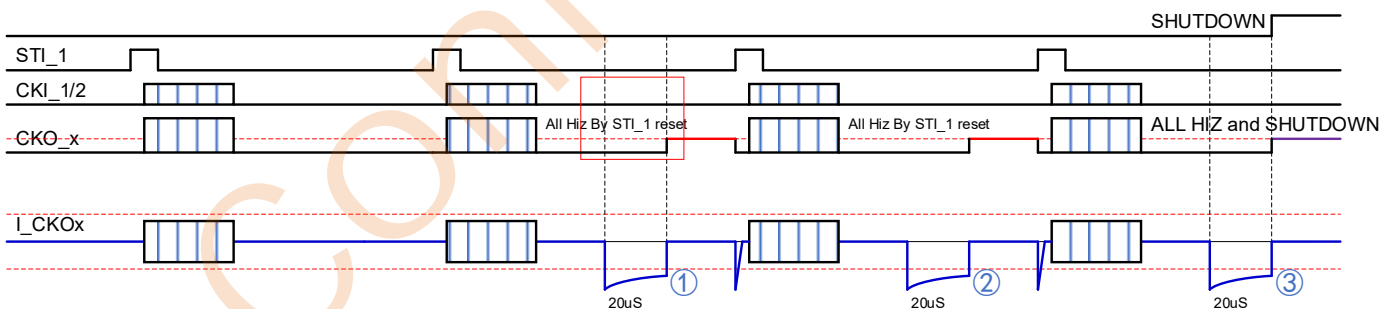

### Other Channel SCP case:

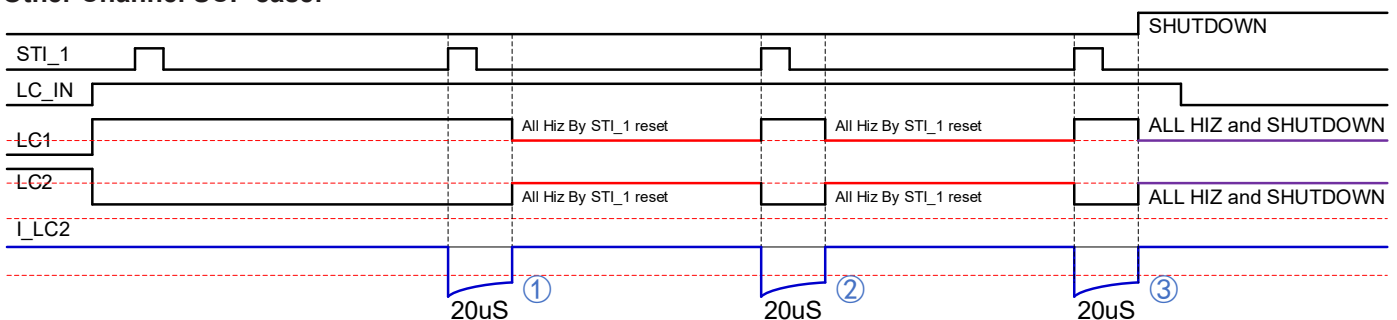

## Protection

Protection	Level Shifter
UVLO(Falling), VIN high to low VGH>UVLO_R	VGH
OTP, T>150°C	OFF(HI-Z)
CKI_1 Keep high/low 128us (CKI_1 protection)	All CKO pull LVGL until next CKI_1
Output over current	OFF(HI-Z)
Short current	OFF(HI-Z)

## XON Function

The LP6274QVF defines a special output timing of the level-shifter output:

Once VIN drops below UVLO falling threshold & CKI\_1 exist, all the output (include XON, STO\_1~2, LC1/LC2 and CKO\_1~CKO\_8) must be pulled high immediately and simultaneously.

When VIN is abnormal as following diagram, XON function will reset (XON is pulled to VGL, CKO\_1~CKO\_8 are pulled to LVGL, and STO\_1~2 and LC1~2 are pulled to LVGL) no matter what voltage level VIN falls to. If VIN falls below UVLO falling in the constraint region (please refer) XON function can't be active. That is, XON, CKO\_1~CKO\_8, STO\_1,STO\_2, and LC1 or LC2 are pulled to LVGL.

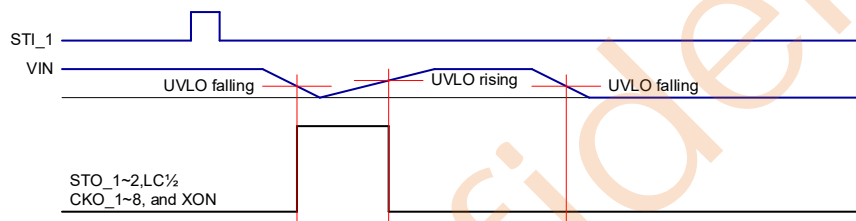

## OTP Function

Overload Thermal protection (OTP) prevents excessive power dissipation from overheating the LP6274QVF. When junction temperature exceeds 150°C, a thermal sensor triggers the OTP, all channel outputs are set to Hi-Z state. Only cycle the VIN can clear the OTP latch and reactivate the device.

## Under-Voltage Lockout (UVLO)

The UVLO circuit compares the input voltage at VIN with the UVLO threshold (2V rising, 1.8V falling, typ.) to ensure the input voltages is high enough for reliable operation. The 200mV(typ.) hysteresis prevents supply transients from causing a shutdown. Once the VIN exceeds the UVLO rising threshold, start-up begins. When VIN falls below the UVLO falling threshold, the controller turns off all of IC internal function.

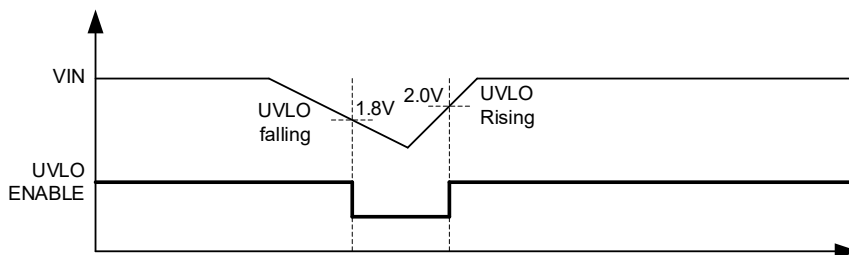

## The Setting Table

PIN	Status	Voltage Level	Level Shifter output
SET1 (*1)	High Level	2.5V~3.6V	8 phase CKO outputs
	Floating	1.2V~2.2V	4 phase CKO outputs, CKO_5~CKO_8 keep in LVGL
	Low Level	0V ~ 0.8V	6 phase CKO outputs, CKO_7, CKO_8 keep in LVGL
SET2 (*2)	High Level	1.5V~3.6V	There is some time interval between CKO_s
	Low Level/Floating	0V~0.8V	There is no time interval between CKO_s
SET3 (*3)	High Level/Floating	1.5V~3.6V	2 clock input mode
	Low Level	0V~0.8V	1 clock input mode
MODE1 (*2)	Extra High Level	3.0V~4.0V	3-line pre-charge
	High Level	1.5V~2.5V	1-line pre-charge
	Middle Level	0.9V~1.4V	No pre-charge
	Low Level	0V~0.8V	2-pine pre-charge
MODE2 (*2)	High Level	1.5V~3.6V	2-line mode on
	Low Level/Floating	0V~0.8V	1-line mode on
DISA_DSTO (*2)	High Level	1.5V~3.6V	STO_1 On (follow STI_1), STO_2 keep in LVGL
	Low Level/Floating	0V~0.8V	STO_1 On (follow STI_1), STO_2 On (follow STI_2)
OCP_EN (*1)	High Level	2.5V~3.6V	OCP Function Disable
	Floating	1.2V~2.2V	OCP Function Enable, current limit level2
	Low Level	0V ~ 0.8V	OCP Function Enable, current limit level1

\* 1 For a tri-state setting pin, it is connected 400KΩ resistor to VIN and 400KΩ to AGND inside.

\* 2 It is connected 400KΩ resistor to AGND inside.

\* 3 It is connected 400KΩ resistor to VIN inside.

## Packaging Information

### QFN4X4-32

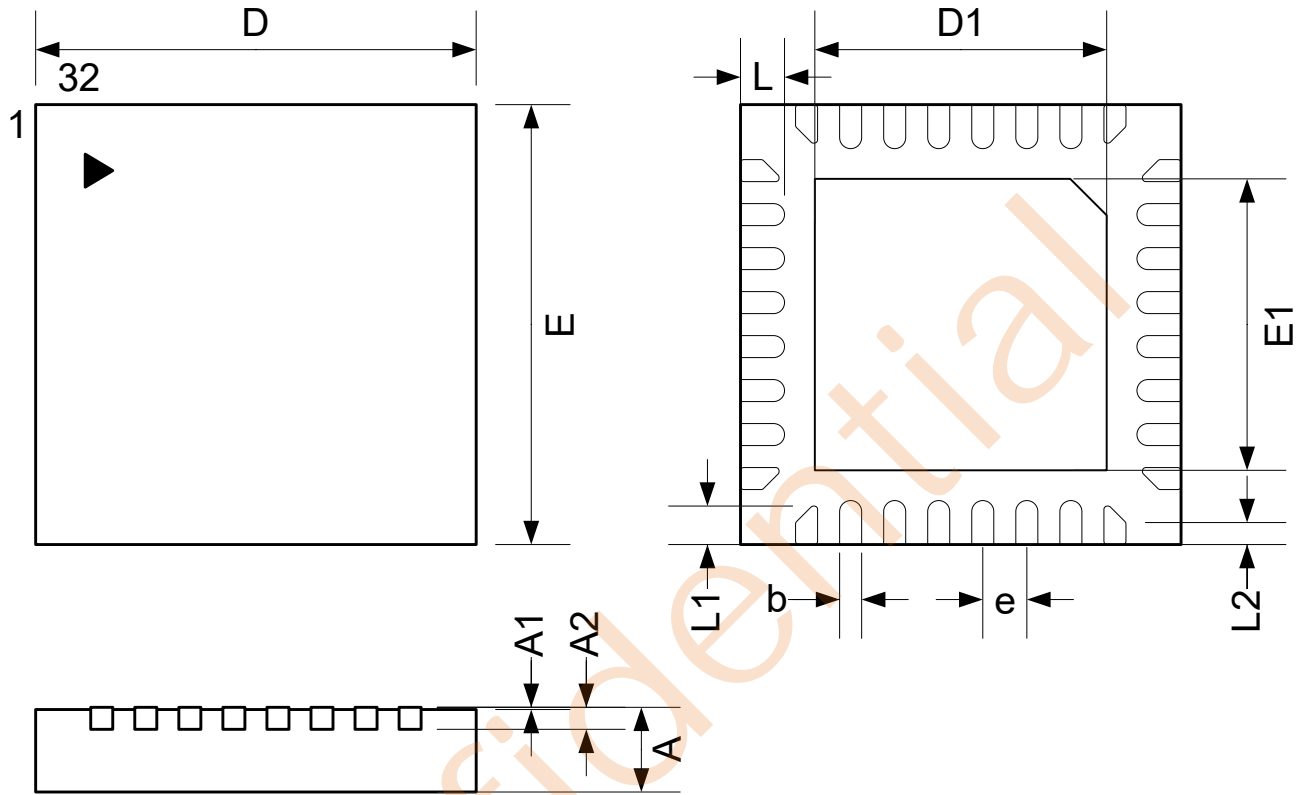

Symbol	DIMENSION IN MM			DIMENSION IN INCH		
	MIN.	NOM.	MAX.	MIN.	NOM.	MAX.
A	0.70	0.75	0.80	0.0276	0.0295	0.0315
A1	0.00	---	0.05	0.0000	---	0.0020
A2	0.20 REF			0.0079 REF		
D	3.95	4.00	4.05	0.1555	0.1575	0.1594
E	3.95	4.00	4.05	0.1555	0.1575	0.1594
D1	2.55	2.65	2.75	0.1004	0.1043	0.1083
E1	2.55	2.65	2.75	0.1004	0.1043	0.1083
b	0.15	0.20	0.25	0.0059	0.0079	0.098
e	0.40 BSC			0.0157 BSC		
L	0.35	0.40	0.45	0.0138	0.0157	0.0177
L1	0.30	0.35	0.40	0.0118	0.0138	0.0157
L2	0.15	0.20	0.25	0.0059	0.0079	0.098