



Features

- Low current consumption: 24μA (Typ)
- Wide input voltage range: 2.0V to 5.5V
- High output voltage accuracy: ±1.5%
- Ultra high PSRR: 98dB at 20mA/1kHz
- Ultra low noise: 10 μVRMS
- Low dropout voltage:
 - 165mV (Typ) at 250mA (V_{OUT} = 1.8V)
- Integrated over-current protection
- Active-high EN pin
- Robust ESD capability:
 - Human Body Model: 4 kV
 - Charged Device Model: 1 kV
- Available in small packages:
 - SOT23-5
 - TDFN-4 (1.0mm × 1.0mm)

Applications

- Wearable Devices
- Portable Medical Equipment
- PDAs, Mobile Phones GPS devices

Naming Information

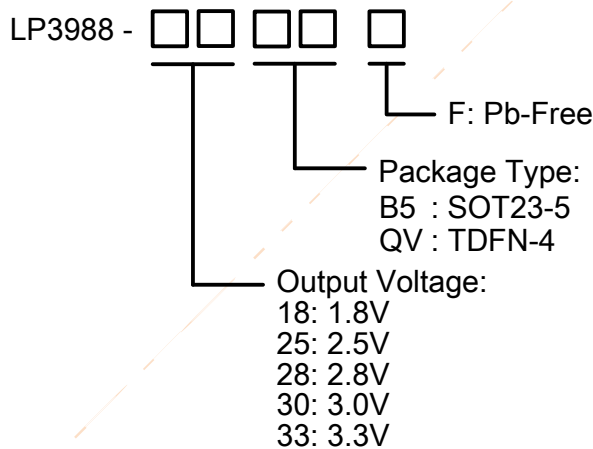

Description

The LP3988 is a low-dropout voltage regulator with very low noise and high PSRR in ultra-small package. The LP3988 can deliver output current up to 300mA. The output voltage could be selected to 1.8V, 2.5V, 2.8V, 3.0V or 3.3V.

The LP3988 is integrated over current protection and short circuit protection in order to protect system abnormal.

The input and output capacitor as small as 1μF will be good enough for LP3988.

The LP3988 is available in 4 pins ultra-small TDFN-4 package with only 1mm × 1mm size or normal SOT23-5 package.



SOT23-5



TDFN-4



Ordering Information

Device	Marking	Moisture Sensitivity Level	Package	Shipping
LP3988-18QVF	CHW	MSL3	TDFN-4	12K/REEL
LP3988-25QVF	CEW	MSL3	TDFN-4	12K/REEL
LP3988-28QVF	CCW	MSL3	TDFN-4	12K/REEL
LP3988-30QVF	CDW	MSL3	TDFN-4	12K/REEL
LP3988-33QVF	CGW	MSL3	TDFN-4	12K/REEL
LP3988-18B5F	LPS CCYWX	MSL3	SOT23-5	3K/REEL
LP3988-25B5F	LPS CDYWX	MSL3	SOT23-5	3K/REEL
LP3988-28B5F	LPS CHYWX	MSL3	SOT23-5	3K/REEL
LP3988-30B5F	LPS CGYWX	MSL3	SOT23-5	3K/REEL
LP3988-33B5F	LPS CEYWX	MSL3	SOT23-5	3K/REEL

Marking indication:
Y: Production year, W: Production week, X: Production batch

Application Diagram

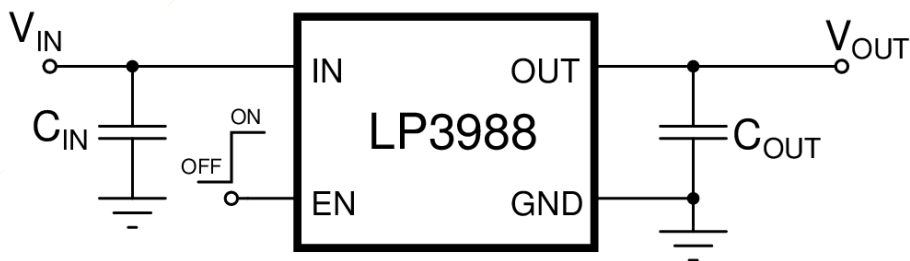



Pin Configuration

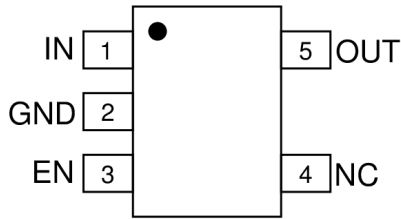

SOT23-5
(Top View)

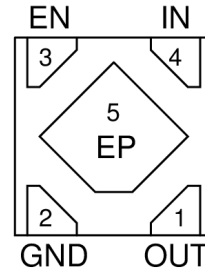

DFN-4
(Bottom View)

Pin Description

Pin No.	Name	Description
TDFN-4		
1	OUT	Regulated output. A minimum 0.1 μ F ceramic capacitor is needed from it to ground.
2	GND	Ground.
3	EN	Active-high enable pin. 1: enable the device. 0 or floating: disable the device.
4	IN	Input and power source. A small capacitor is recommended from this pin to ground.
5	EP	Exposed Pad for thermal dissipation. Need to be tied to ground.
SOT23-5		
1	IN	Input and power source. A small capacitor is recommended from this pin to ground.
2	GND	Ground.
3	EN	Active-high enable pin. 1: enable the device. 0 or floating: disable the device.
4	NC	Not connected.
5	OUT	Regulated output. A minimum 0.1 μ F ceramic capacitor is needed from it to ground.



Functional Block Diagram

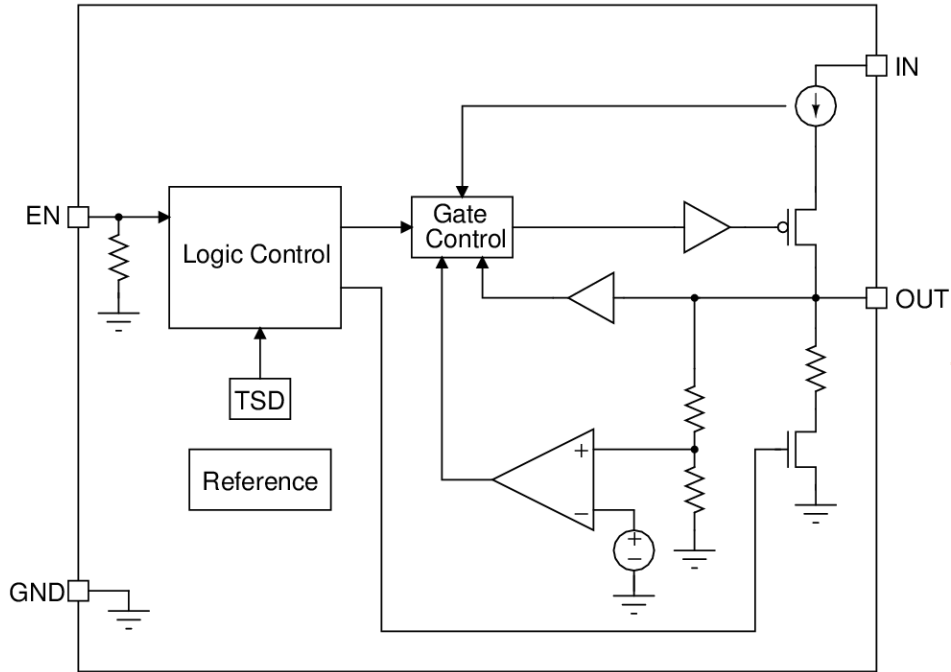



Absolute Maximum Ratings (Note 1)

- IN to GND ----- -0.3V to 6V
- OUT to GND ----- -0.3V to ($V_{IN} + 0.3V$) or 6V
- EN to GND ----- -0.3V to 6V
- Maximum Junction Temperature (T_J) ----- 150°C
- Maximum Soldering Temperature (At leads, 10 sec) ----- 260°C

*Note 1: Stresses beyond those listed under “Absolute Maximum Ratings” may cause permanent damage to the device. These are stress ratings only, and functional operation of the device at these or any other conditions beyond those indicated in the operational sections of the specifications is not implied. Exposure to absolute maximum rating conditions for extended periods may affect device reliability.

Thermal Information

- Maximum Power Dissipation (TDFN-4L, P_D , $T_A \leq 25^\circ\text{C}$) ----- 480mW
- Maximum Power Dissipation (SOT23-5L, P_D , $T_A \leq 25^\circ\text{C}$) ----- 610mW
- Thermal Resistance (TDFN-4L, θ_{JA}) (Note 2) ----- 256 °C/W
- Thermal Resistance (SOT23-5L, θ_{JA}) (Note 2) ----- 203 °C/W

*Note 2: Measured using 2S2P JEDEC standard PCB with ambient temperature < 25°C

Electro-Static Discharge and Latch-up

- HBM (Human Body Model, JEDEC JS-001) ----- 4000V
- CDM (Charged Device Model, JEDEC JS-002) ----- 1000V

Recommended Operating Conditions

- Input and supply voltage on IN ----- 2.5V to 5.5V
- Output DC current ----- Up to 300mA
- Input and Output capacitor ----- > 1μF
- Operating ambient temperature ----- -40°C to 85°C



Electrical Characteristics

The parameters are specified under conditions: V_{IN} is equal to the greater value between $V_{OUT(NOM)} + 0.5V$ and $2.0V$, $-40^{\circ}C \leq T_J \leq 85^{\circ}C$, $I_{OUT} = 1mA$, $C_{IN} = C_{OUT} = 1\mu F$, unless otherwise noted. Typical values are at $T_J = 25^{\circ}C$.

Parameter	Symbol	Test Conditions	Min	Typ.	Max	Units
Output Voltage at 25°C	V_{OUT}	$V_{IN} = 2.8V$, LP3988-18B5F/QVF	1.77	1.80	1.83	V
		$V_{IN} = 3.5V$, LP3988-25B5F/QVF	2.46	2.50	2.54	V
		$V_{IN} = 3.8V$, LP3988-28B5F/QVF	2.76	2.80	2.84	V
		$V_{IN} = 4.0V$, LP3988-30B5F/QVF	2.95	3.00	3.05	V
		$V_{IN} = 4.3V$, LP3988-33B5F/QVF	3.24	3.30	3.36	V
Output voltage accuracy		$V_{OUT(NOM)} = 1.8V$, $T_J = 25^{\circ}C$	-1.5		1.5	%
Output voltage accuracy over temperature		$V_{OUT(NOM)} = 1.8V$, $-40^{\circ}C \leq T_J \leq 85^{\circ}C$	-2.0		2.0	%
Input quiescent current	I_Q	$V_{IN} = 2V$ to $5.5V$, $V_{EN} = V_{IN}$, no load		24		μA
Input shutdown current	I_{SHDN}	$V_{IN} = 2V$ to $5.5V$, $V_{EN} = 0V$, no load			1	μA
Line regulation	$\frac{\Delta V_{OUT}}{\Delta V_{IN} \times V_{OUT}}$	$I_{OUT} = 1mA$, $V_{IN} = (V_{OUT(NOM)} + 1V)$ to $5.5V$, $T_A = 25^{\circ}C$		0.002		%/V
Load regulation	ΔV_{LOAD}	$I_{OUT} = 1mA$ to $250mA$, $V_{IN} = V_{OUT(NOM)} + 1V$, $T_A = 25^{\circ}C$		5		mV
Dropout voltage in SOT23-5	V_{DROP}	$V_{OUT(NOM)} = 1.8V$, $I_{OUT} = 100mA$, $T_A = 25^{\circ}C$		66		mV
		$V_{OUT(NOM)} = 1.8V$, $I_{OUT} = 250mA$, $T_A = 25^{\circ}C$		165		mV
		$V_{OUT(NOM)} \geq 2.8V$, $I_{OUT} = 100mA$, $T_A = 25^{\circ}C$		50		mV
		$V_{OUT(NOM)} \geq 2.8V$, $I_{OUT} = 250mA$, $T_A = 25^{\circ}C$		125		mV
Output current limit	I_{LIM}	$V_{OUT(NOM)} = 1.8V$, $V_{IN} = V_{OUT(NOM)} + 1V$, $V_{OUT} = 0.9 \times V_{OUT(NOM)}$		350		mA
Output voltage noise	V_{NOISE}	$BW = 10Hz$ to $100kHz$, $I_{OUT} = 20mA$		10		μV_{RMS}
Power supply rejection ratio	PSRR	$V_{IN} = V_{OUT(NOM)} + 1V$, $I_{OUT} = 20mA$, $f = 1kHz$, $\Delta V_{RIPPLE} = 0.2 \times V_{PP}$		98		dB
EN logic high voltage level	V_{IH}		1.1			V
EN logic low voltage level	V_{IL}				0.4	V
EN pull-down current	I_{EN_PD}			200		nA
Output discharge resistance	R_{DIS}	$V_{EN} = 0V$		300		Ω



Function Description

Overview

The LP3988 is a Low dropout voltage regulator with ultra-low noise and ultra-high PSRR. It has fixed output voltage with good transient performance and no external setting resistors needed. The product is available in ultra-small package 1mm x 1mm TDFN-4 or traditional SOT23-5.

Selectable output voltage

The product will output fixed voltage as long as the input voltage is higher than $V_{OUT(NOM)} + V_{DROP}$. $V_{OUT(NOM)}$, the output voltage, can be selected.

Enable function

The EN pin is an active high Logic input pin that is compatible with 1.8V control logic. The internal power element is turned off when EN pin is tied low.

When the EN pin is pulled high, the LP3988 will be activated and output voltage according to setting.

Auto discharge

The LP3988 has a quick discharge function. When the device is disabled by pulled down EN pin, a discharge resistor is connected between OUT and GND. The resistance is 300Ω (typical).

Power Supply Rejection Ratio

The LP3988 is working with ultra-high Power Supply Rejection Ratio (PSRR). By selecting proper output capacitor and PCB layout, the PSRR could even be tuned to higher.

Over current protection

The device features a current limit function when the over current event is detected to reach 350mA (Typ). The output current will be clamped and output voltage will drop accordingly, as in the *Electrical Characteristics Table*.

Application Information

Capacitor consideration

External capacitors on IN and OUT are recommended in application, 1μF for C_{OUT} and C_{IN} at least. Closer placement of the capacitors to the device, both IN and OUT, would be better for stability.

Power Dissipation

The internal power dissipation from the power MOSFET, when it is turned on, is the main source of junction temperature rising. In this case, the power dissipation and the junction temperature in conducting mode can be calculated as following:

$$P_D = (V_{IN} - V_{OUT}) \times I_{OUT}$$

P_D : Power Dissipation (W)

V_{IN} : Input voltage (V)

V_{OUT} : Output voltage (V)

I_{OUT} : Output current (A)

$$T_J = P_D \times \theta_{JA} + T_A$$

T_J : Junction temperature (°C)

θ_{JA} : Package thermal resistance (°C /W) (Note 4)

T_A : Ambient temperature (°C)

***Note 4: The calculation base on thermal resistance is only valid in Lab condition. The value of θ_{JA} could change in customer PCB environment.**



Package Dimensions

SOT23-5

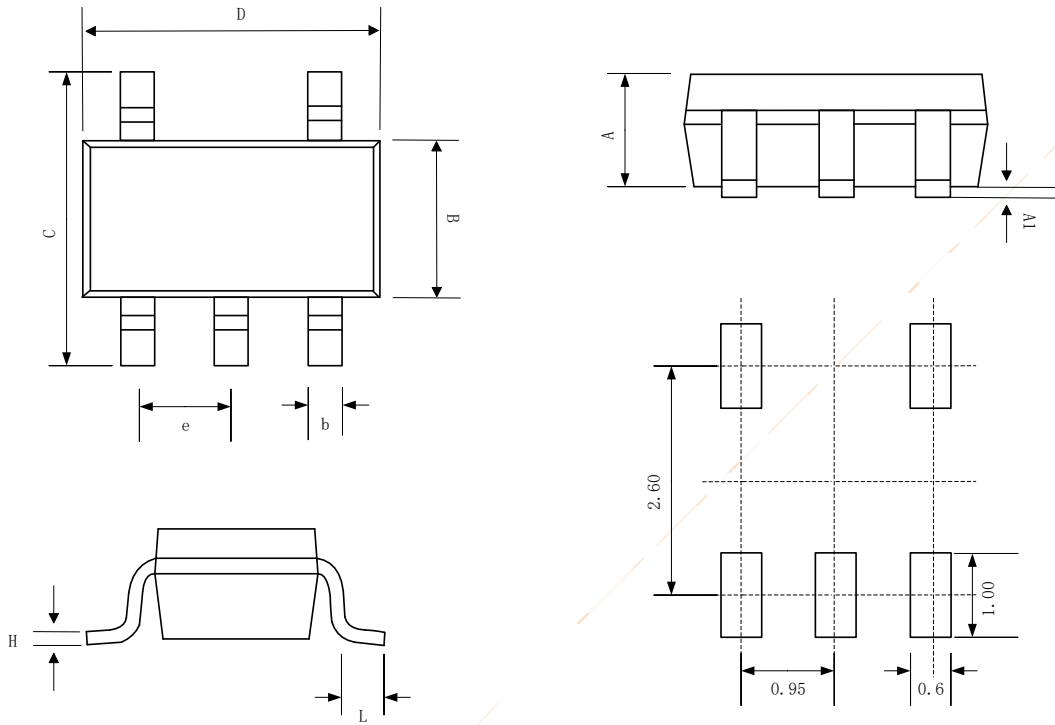

Recommended Land Pattern

SYMBOL	Dimensions In Millimeters		
	MIN	NOM	MAX
A	0.889	1.100	1.295
A1	0.000	0.050	0.152
B	1.397	1.600	1.803
b	0.28	0.35	0.559
C	2.591	2.800	3.000
D	2.692	2.920	3.120
e	0.95BSC		
H	0.080	0.152	0.254
L	0.300	0.450	0.610



TDFN-4, 1mm x 1mm

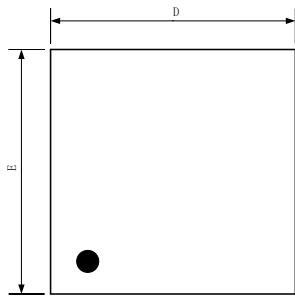

TOP VIEW

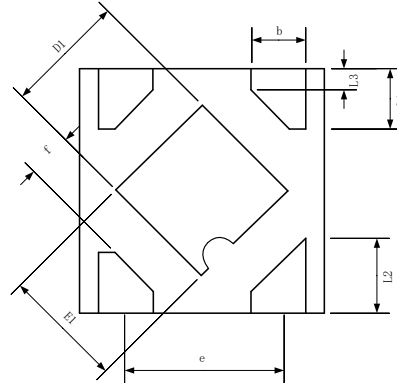

BOTTOM VIEW

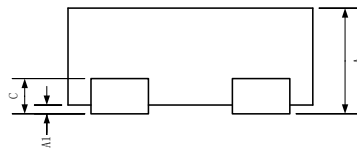

SIDE VIEW

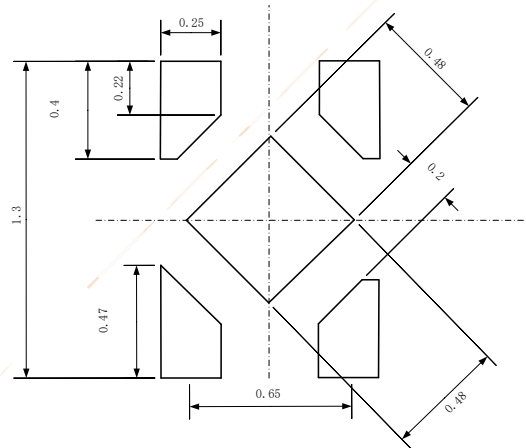

Recommended Land Pattern

SYMBOL	MILLIMETER		
	MIN	NOM	MAX
A	0.35	-	0.40
A1	0.00	0.02	0.05
b	0.20	0.25	0.30
c	0.07	0.12	0.17
D	0.95	1.00	1.05
D1	0.43	0.48	0.55
E	0.95	1.00	1.05
E1	0.43	0.48	0.55
e	0.65BSC		
L1	0.2	0.25	0.30
L2	0.27	0.32	0.37
L3	0.09REF		
f	0.18REF		