

## 1000mA Single Chip Li-Ion and Li-Polymer Charger

### General Description

The LP28011H is a complete constant-current/ constant voltage linear charger for single cell lithium-ion battery. Its DFN-10 package and low external component count make the LP28011H ideally suited for portable applications. No external sense resistor is needed, and no blocking diode is required due to the internal MOSFET architecture. Thermal feedback regulates the charge current to limit the die temperature during high power operation or high ambient temperature. The charge voltage is fixed at 4.2V, and the charge current can be ISET programmed externally with a single resistor.

When the input supply is removed, the LP28011H automatically enters a low current state, dropping the battery drain current to less than  $< 1\mu\text{A}$ .

Other features include charge current monitor, under voltage lockout, automatic recharge and a status pin to indicate charge termination and the presence of an input voltage.

### Order Information

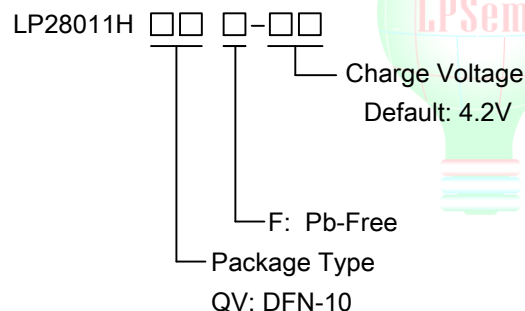

### Applications

- ✧ Portable Media Players/Game
- ✧ Power Bank
- ✧ Bluetooth Applications
- ✧ PDA/MID

### Features

- ◆ input voltage up to 28V
- ◆ input Over Voltage Protection : 6.5V
- ◆ Short-circuit protection
- ◆ Programmable Charge Current up to 1000mA
- ◆  $< 1\mu\text{A}$  Battery Reverse Current
- ◆ Protection of Reverse Connection of Battery
- ◆ No MOSFET, Sense Resistor or Blocking Diode Required
- ◆ Constant-Current/Constant-Voltage Operation with Thermal Regulation to Maximize Charge Rate Without Risk of Overheating
- ◆ DFN-10 3mmx3mm Package
- ◆ RoHS Compliant and 100% Lead (Pb)-Free

### Typical Application Circuit

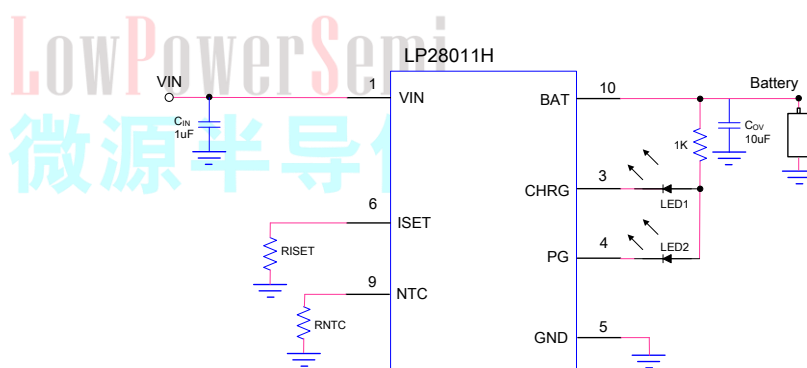

### Marking Information

Device	Marking	Package	Shipping
LP28011HQVF	LPS LP28011H YWXXX	DFN-10	5K/REEL
Marking indication: Y:Production year W:Production week X: Series Number			

## Functional Pin Description

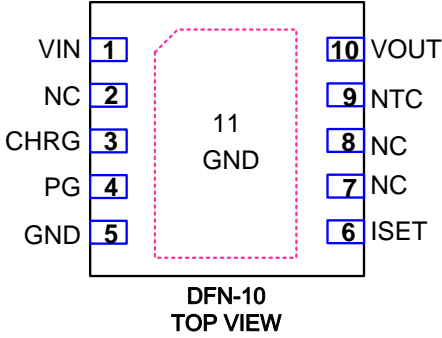
Package Type	Pin Configurations
DFN-8	 <p style="text-align: center;">DFN-10 TOP VIEW</p>

## Pin Description

PIN No.	PIN NAME	DESCRIPTION
1	VIN	VIN is the input power source. Connect to a wall adapter.
2/7/8	NC	No Connector.
3	CHRG	Open-Drain Charge Status Output. When the battery is charging, the CHRG pin is pulled low by an internal NMOS. When the charge cycle is completed, the pin could be pulled High by an external pull high resistor.
4	PG	Open-Drain Status Output. Low indicates the input voltage is above UVLO and the OUT (battery) voltage.
5	GND	GND is the connection to system ground.
6	ISET	Charge Current Program. The charge current is programmed by connecting a 1% resistor( $R_{ISET}$ ) to ground.
9	NTC	Negative Thermal Coefficient (NTC) Thermistor Pin.
10	BAT	BAT is the connection to the battery. Typically a 10 $\mu$ F Tantalum capacitor is needed for stability when there is no battery attached. When a battery is attached, only a 1 $\mu$ F ceramic capacitor is required.

## Function Block Diagram

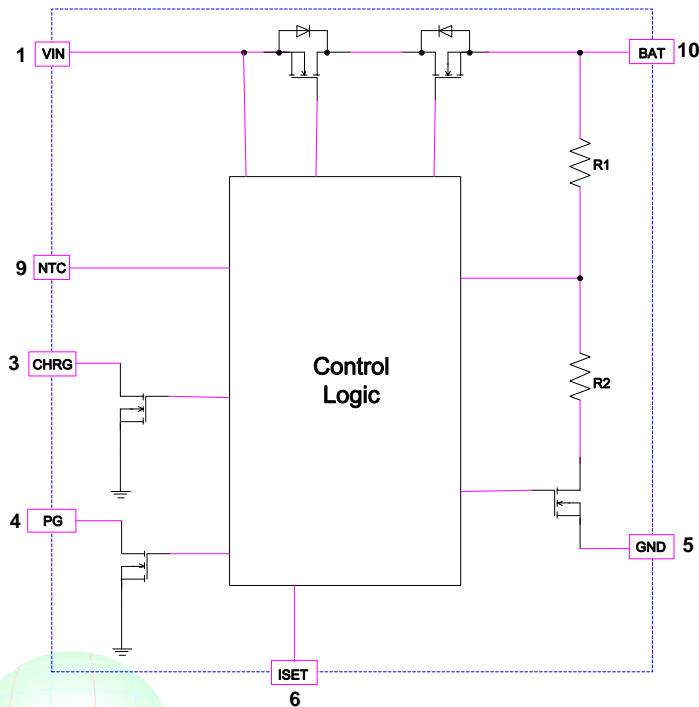

## Absolute Maximum Ratings <sup>Note 1</sup>

◇ Input Voltage to GND	-----	-0.3V to 28V
◇ BAT voltage GND	-----	- 5V to 6.5V
◇ Other pin to GND	-----	-0.3V to 6.5V
◇ Output current	-----	1200mA
◇ Maximum Junction Temperature	-----	125°C
◇ Maximum Soldering Temperature (at leads, 10 sec)	-----	260°C
◇ Storage Temperature	-----	-60°C to 125°C

## Thermal Information

◇ Thermal Resistance ( $\theta_{JA}$ )	-----	76°C/W
--	-------	--------

## ESD Susceptibility

◇ HBM(Human Body Mode)	-----	2KV
◇ MM(Machine Mode)	-----	200V

**Note 1.** Stresses beyond those listed under “Absolute Maximum Ratings” may cause permanent damage to the device. These are stress ratings only, and functional operation of the device at these or any other conditions beyond those indicated in the operational sections of the specifications is not implied. Exposure to absolute maximum rating conditions for extended periods may affect device reliability.

## Recommended Operating Conditions

◇ Input supply voltage	-----	4.5V to 5.8V
◇ Operating Ambient Temperature Range	-----	-40°C to 85°C

## Electrical Characteristics

( $T_A = 25^\circ\text{C}$ .  $V_{IN} = 5\text{V}$ , unless otherwise noted.)

SYMBOL	PARAMETER	CONDITIONS	MIN	TYP.	MAX	UNITS
$I_{IN}$	Input Supply Current			250		$\mu\text{A}$
$V_{FLOAT}$	Regulated Output (Float) Voltage	$I_{BAT}=40\text{mA}$	4.158	4.2	4.242	V
$V_{UV}$	$V_{IN}$ Under voltage Lockout Threshold	From $V_{IN}$ Low to High		3.3		V
$V_{UVHYS}$	$V_{IN}$ Under voltage Lockout Hysteresis			150		mV
$V_{OVP}$	Input Voltage OVP	$V_{IN}$ Rising		6.5		V
$V_{OVP-HYS}$	OVP Hysteresis			0.2		V
$I_{BAT}$	BAT Pin Current	$R_{ISET} = 10\text{k}$ , Current Mode		170		mA
		$R_{ISET} = 4\text{k}$ , Current Mode		425		mA
		$V_{BAT} = 4.2\text{V}$ , $V_{in}=\text{float}$		1		$\mu\text{A}$
$I_{TRIKL}$	Trickle Charge Current	$V_{BAT} < V_{TRIKL}$ , Current Mode		10		$\%I_{BAT}$
$V_{TRIKL}$	Trickle Charge Threshold Voltage	$V_{BAT}$ Rising		2.6		V
$V_{TRHYS}$	Trickle Charge Hysteresis Voltage			150		mV
$I_{TERM}$	Termination Current Threshold			10		$\%I_{BAT}$
$V_{ISET}$	ISET Pin Voltage	$R_{ISET} = 10\text{k}$ , Current		1		V
$I_{STAT}$	CHRG/PG Pin Weak Pull-Down Current	$V_{STAT} = 5\text{V}$			5	$\mu\text{A}$
$V_{STAT}$	CHRG Pin Output Low Voltage	$I_{STAT} = 5\text{mA}$			0.5	V
$\Delta V_{RESTAT}$	Recharge Battery Threshold Voltage	$V_{FLOAT} - V_{RESTAT}$		150		mV
$V_{NTC-0^\circ\text{C}}$	Low temperature pending voltage threshold			1.18		V
$V_{NTC-10^\circ\text{C}}$	half charging current mode voltage threshold (Low temperature)			0.75		V
$V_{NTC-60^\circ\text{C}}$	High temperature Disable voltage threshold			0.17		V
$V_{NTC-HYS}$	Hysteresis			40		mV
$I_{NTC}$	NTC bias current	$R_{NTC}=10\text{K}$		47		$\mu\text{A}$
$T_{LIM}$	Junction Temperature in Thermal Protection			125		$^\circ\text{C}$

## Application Information

### Input Voltage Range

The LP28011H has built-in input voltage surge protection as high as +28V. The charger IC will be automatically disabled when the input voltage is lower than 3.3V or higher than 6.5V. The open-drain PG Pin is used to indicate an input power good condition (3.3V<VIN<5.8V). If the input voltage is lower than the battery voltage, the IC is also disabled to prevent the battery from draining.

A charge cycle begins when the voltage at the VIN pin rises above the UVLO threshold level, when a battery is connected to the charger output. If the BAT pin is less than 2.6V, the charger enters trickle charge mode. In this mode, the LP28011H supplies approximately 1/10 the ISET programmed charge current to bring the battery voltage up to a safe level for full current charging. When the BAT pin voltage rises above 2.6V, the charger enters constant-current mode(CC), where the ISET programmed charge current is supplied to the battery. When the BAT pin approaches the final float voltage, the LP28011H enters constant-voltage mode(CV) and the charge current begins to decrease, and the battery full indication is set when the charge current in the CV mode is reduced to the programmed full battery current (IBF).

### ISET programming Charge Current

The charge current (IBAT) is set by a resistor (RISET) connecting from the ISET pin to GND. The relationship of the charge current and the programming resistance is established by the following table.

$$I_{BAT}(mA) = V_{ISET} \times 1700 / R_{ISET}(K\Omega)$$

### Automatic Recharge

Once the charge cycle is terminated, the LP28011H continuously monitors the voltage on the BAT pin. A charge cycle restarts when the battery voltage falls below 4.05V (which corresponds to approximately 80% to 90% battery capacity). This ensures that the battery is kept at or near a fully charged condition and eliminates the need for periodic charge cycle initiations.

### Automatic Recharge

Once the charge cycle is terminated, the LP28011H continuously monitors the voltage on the BAT pin. A charge cycle restarts when the battery voltage falls below 4.05V (which corresponds to approximately 80% to 90% battery capacity). This ensures that the battery is kept at or near a fully charged condition and eliminates the need for periodic charge cycle initiations.

### Battery Temperature Detection

The NTC function for the LP28011H is designed to follow the new JEITA temperature standard for Li-Ion. There are now three thresholds, 60°C, 10°C, and 0°C. Normal operation occurs between 10°C and 60°C. If between 0°C and 10°C the charge current level is cut in half. Above 60°C or below 0°C the charge is disabled.

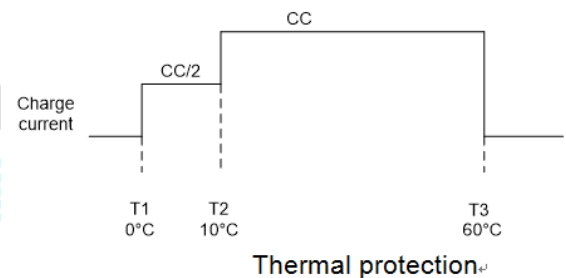

The NTC feature is implemented using an internal 48µA current source to bias the thermistor connected from the NTC terminal to GND(designed for use with a 10k NTC β = 3370 [SEMITEC 103AT-2 or Mitsubishi TH05-3H103F]). If NTC feature is not needed, a fixed 10kΩ can be placed between NTC and GND to allow normal operation. Since the INTC current is fixed along with the temperature thresholds, it is not possible to use thermistor values other than the 10k NTC (at 25°C).

### Charge Status Indicator (CHAG & PG)

After application of a 5V source, the input voltage rises above the  $UVLO$  and sleep thresholds ( $V_{IN} > V_{BAT} + V_{DT}$ ), but is less than  $OVP$  ( $V_{IN} < V_{OVP}$ ), then the PG turns on and provides a low impedance path to ground.

CHRG has two different states: strong pull-down (~5mA) and high impedance. The strong pull-down state indicates that the LP28011H is in a charge cycle. When the charger is entered CV mode and Once the charge current has reduced to the battery full charge current threshold (IBF), the CHRG pin will become high impedance.

Function	CHRG
Charging	Low
Charge END	High

Function	PG
$V_{IN} < UVLO$	High
$UVLO < V_{IN} < OVP$	Low
$OVP < V_{IN}$	High

### Thermal Limiting

An internal thermal feedback loop reduces the I SET rrammed charge current if the die temperature attempts to rise above a preset value of approximately 125°C. This feature protects the LP28011H from excessive temperature and allows the user to push the limits of the power handling capability of a given circuit board without risk of damaging the LP28011H. The charge current can be set according to typical (not Worst-case) ambient temperature with the assurance that the charger will automatically reduce the current in worst-case conditions.

### Power Dissipation

The conditions that cause the LP28011H to reduce charge current through thermal feedback can be approximated by considering the power dissipated in the IC. Nearly all of this power dissipation is generated by the internal MOSFET calculated to be approximately:

$$P_D = (V_{IN} - V_{BAT}) \cdot I_{BAT}$$

where PD is the power dissipated,  $V_{IN}$  is the input supply voltage,  $V_{BAT}$  is the battery voltage and  $I_{BAT}$  is the charge current. The approximate ambient temperature at which the thermal feedback begins to protect the IC is:

$$T_A = 125^{\circ}\text{C} - P_D \cdot \theta_{JA}$$

## Packaging Information

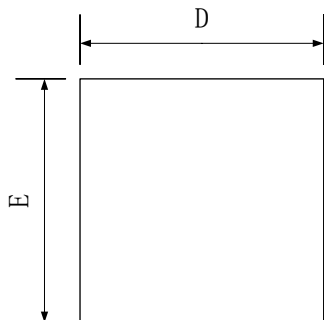

TOP VIEW

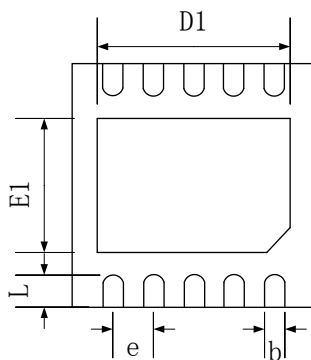

BOTTOM VIEW

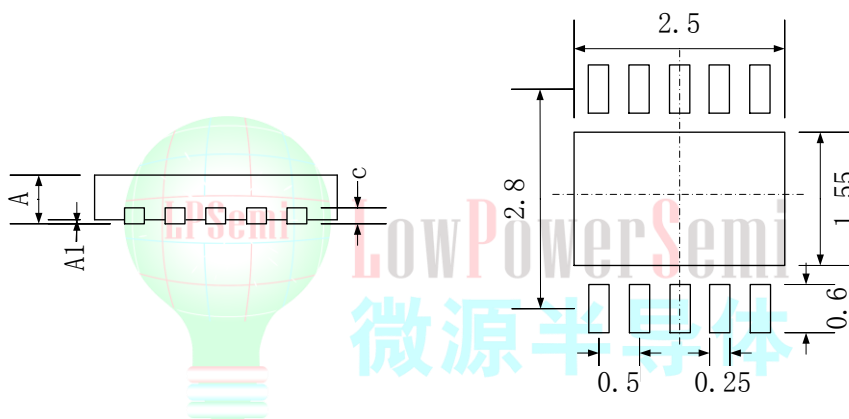

SIDE VIEW

Recommended Land Pattern

SYMBOL	MILLIMETER		
	MIN	NOM	MAX
A	0.70	0.75	0.80
A1	0.00	0.02	0.05
b	0.18	0.25	0.30
C	0.20 REF		
D	2.90	3.00	3.10
D1	2.40	2.50	2.60
E	2.90	3.00	3.10
E1	1.45	1.55	1.65
e	0.50 BSC		
L	0.30	0.40	0.50