

## 600mA, Ultra-low noise, Ultra-Fast CMOS LDO Regulator

### General Description

The LP3987H is designed for portable RF and wireless applications with demanding performance and space requirements. The LP3987H performance is optimized for battery-powered systems to deliver ultra low noise and low quiescent current. Regulator ground current increases only slightly in dropout, further prolonging the battery life. The LP3987H also works with low-ESR ceramic capacitors, reducing the amount of board space necessary for power applications, critical in hand-held wireless devices. The LP3987H consumes less than 0.01 $\mu$ A in shutdown mode and has fast turn-on time less than 20 $\mu$ s. The other features include ultra low dropout voltage, high output accuracy, current limiting protection, and high ripple rejection ratio. It is available in the 5-lead of SOT23-5 packages.

### Order Information

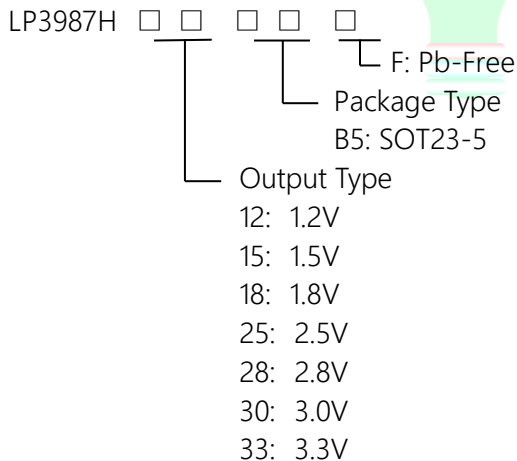

### Applications

- ✧ Portable Media Players/MP3 players
- ✧ Cellular and Smart mobile phone
- ✧ Sensor Module, RF Module

### Features

- ◆ Ultra-Low-Noise for RF Application
- ◆ 2.5V~6.0V Input Voltage Range
- ◆ Low Dropout: 360mV @ 600mA
- ◆ High PSRR: -65dB at 1KHz
- ◆ <0.01 $\mu$ A Standby Current When Shutdown
- ◆ Ultra-Fast Response in Line/Load transient
- ◆ Current Limiting and Thermal Shutdown Protection

### Typical Application Circuit

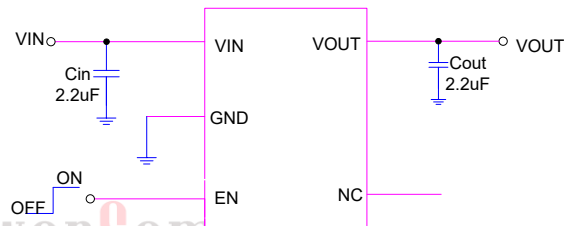

### Marking Information

Device	Marking	Package	Shipping
LP3987H-12B5F	LPS 1BYWX	SOT23-5	3K/REEL
LP3987H-15B5F	LPS 1NYWX	SOT23-5	3K/REEL
LP3987H-18B5F	LPS 1CYWX / LPS 0CYWX	SOT23-5	3K/REEL
LP3987H-25B5F	LPS 1DYWX	SOT23-5	3K/REEL
LP3987H-28B5F	LPS 1hYWX	SOT23-5	3K/REEL
LP3987H-30B5F	LPS 1GYWX	SOT23-5	3K/REEL
LP3987H-33B5F	LPS 1eYWX	SOT23-5	3K/REEL

Marking indication:

Y: Y is year code. W: W is week code. X: X is series number.

## Functional Pin Description

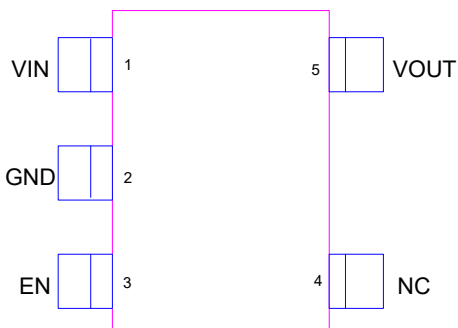
Package Type	Pin Configurations
SOT23-5	<p>Top View / SOT23-5</p> 

## Pin Description

Pin	Name	Description
1	VIN	Power Input Voltage.
2	GND	Ground.
3	EN	Chip Enable (Active High). Note that this pin is high impedance. There is an integrated pull low 1MΩ resistor connected to GND when the control signal is floating.
4	NC	No connection.
5	VOUT	Output Voltage.

## Function Diagram

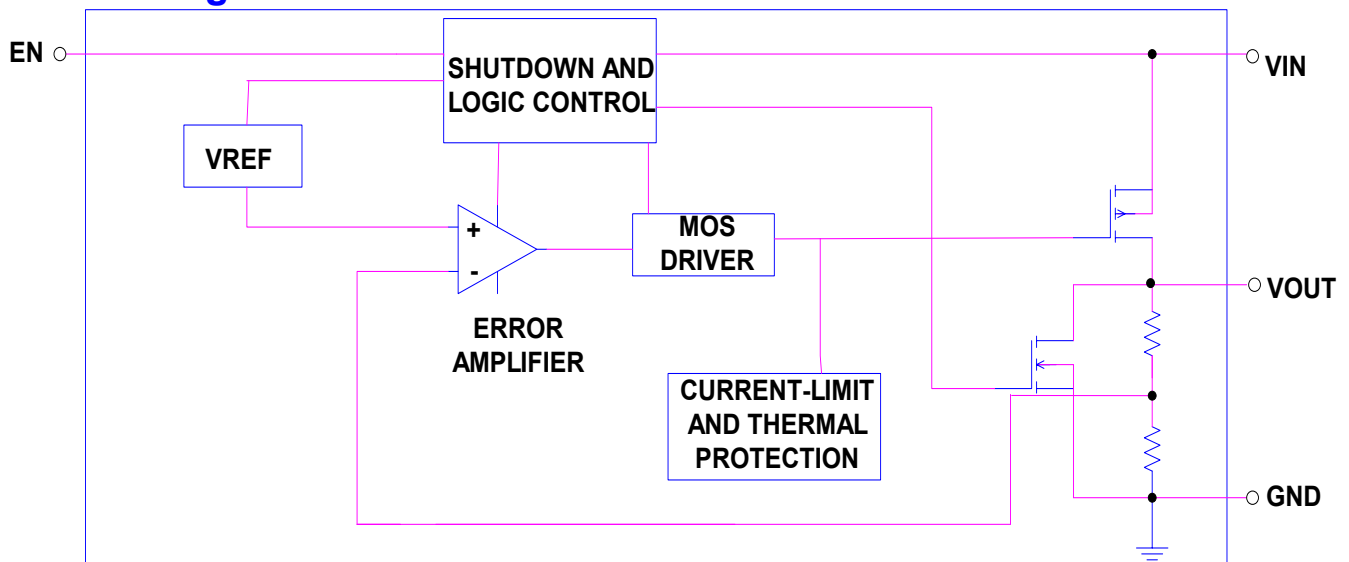

## Absolute Maximum Ratings

- ✧ Input Voltage to GND ----- -0.3V to 6.5V
- ✧ Other pin to GND ----- -0.3V to 6V
- Power Dissipation,  $P_D$  @  $T_A=25^\circ\text{C}$
- ✧ Maximum Power Dissipation (  $P_D, T_A=25^\circ\text{C}$ ) ----- 0.5W
- Package Thermal Resistance
- ✧ Thermal Resistance ( $J_A$ ) -----  $195^\circ\text{C/W}$
- ✧ Thermal Resistance ( $J_C$ ) -----  $60^\circ\text{C/W}$
- ✧ Maximum Junction Temperature -----  $150^\circ\text{C}$
- ✧ Maximum Soldering Temperature (at leads, 10 sec) -----  $260^\circ\text{C}$
- ✧ Storage Temperature Range -----  $-60^\circ\text{C}$  to  $125^\circ\text{C}$
- ESD Susceptibility
- ✧ HBM (Human Body Mode) ----- 2kV
- ✧ MM(Machine-Mode) ----- 200V
- Recommended Operating Conditions
- ✧ Supply Input Voltage ----- 2.5V to 6V
- ✧ Operation Junction Temperature Range -----  $-40^\circ\text{C}$  to  $125^\circ\text{C}$
- ✧ Operation Ambient Temperature Range -----  $-40^\circ\text{C}$  to  $85^\circ\text{C}$

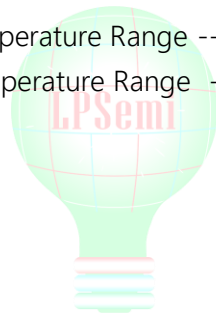

## Electrical Characteristics

( $V_{IN}=V_{OUT}+0.8V$ ,  $C_{IN}=C_{OUT}=1\mu F$ ,  $T_A=25^\circ C$ , unless otherwise specified)

Parameter		Symbol	Test Conditions	Min	Typ.	Max	Units
Output Voltage Accuracy		$\Delta V_{OUT}$	$I_{OUT}=1mA$	-2	--	+2	%
Output Current		$I_{OUT}$	$V_{EN}=V_{IN}$ , $V_{IN}>2.5V$		600		mA
Current Limit		$I_{LIM}$	$R_{LOAD}=1\Omega$		800		mA
Quiescent Current		$I_Q$	$V_{EN}\geq 1.4V$ , Output floating		110	130	$\mu A$
Dropout Voltage		$V_{DROP}$	$I_{OUT}=100mA$ , $V_{OUT}>2.8V$		60	80	mV
			$I_{OUT}=600mA$ , $V_{OUT}>2.8V$		360	480	
Line Regulation		$\Delta V_{LINE}$	$V_{IN}=(V_{OUT}+1V)$ to 5.5V, $I_{OUT}=1mA$			0.2	%
Load Regulation		$\Delta V_{LOAD}$	$1mA<I_{OUT}<300mA$			2	%
Standby Current		$I_{STBY}$	$V_{EN}=0V$ , Shutdown		0.01	1	$\mu A$
EN Input Bias Current		$I_{IBSD}$	$V_{EN}=5V$		4	6	$\mu A$
EN Threshold	Logic-Low Voltage	$V_{IL}$	$V_{IN}=3V$ to 5.5V, Shutdown			0.4	V
	Logic-High Voltage	$V_{IH}$	$V_{IN}=3V$ to 5.5V, Start-Up	1.4		$V_{IN}+$ 0.3	
Output Noise Voltage			10Hz to 100kHz, $I_{OUT}=200mA$ , $C_{OUT}=1\mu F$		100		$\mu VRMS$
Power Supply Rejection Rate	f=1kHz	PSRR	$C_{OUT}=1\mu F$ , $I_{OUT}=10mA$		-65		dB
	f=10kHz				-55		
Thermal Shutdown Temperature		$T_{SD}$			150		$^\circ C$

## Typical Operating Characteristics

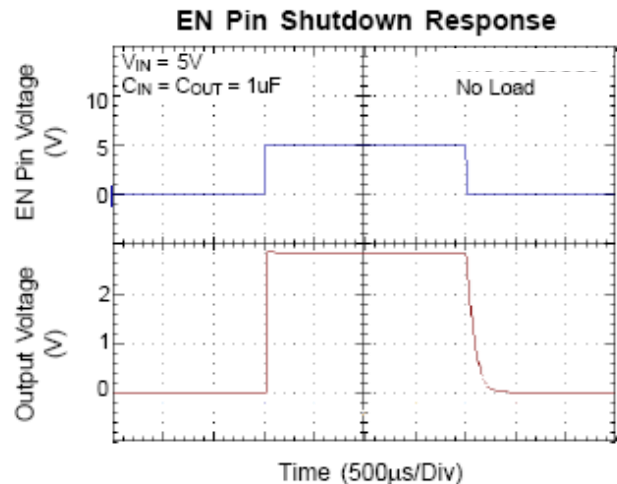
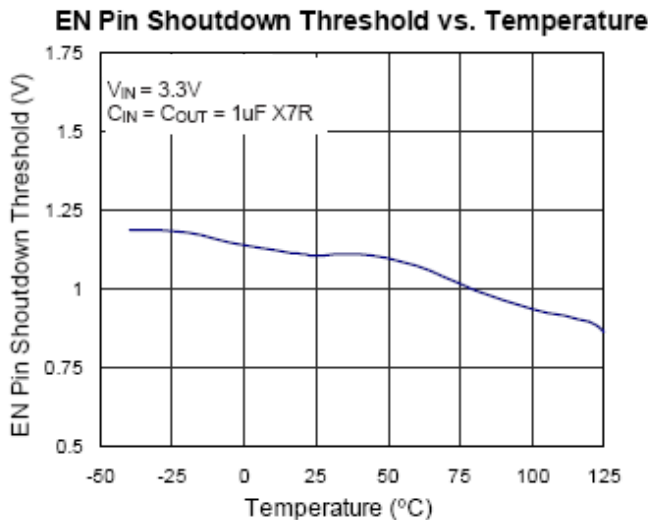
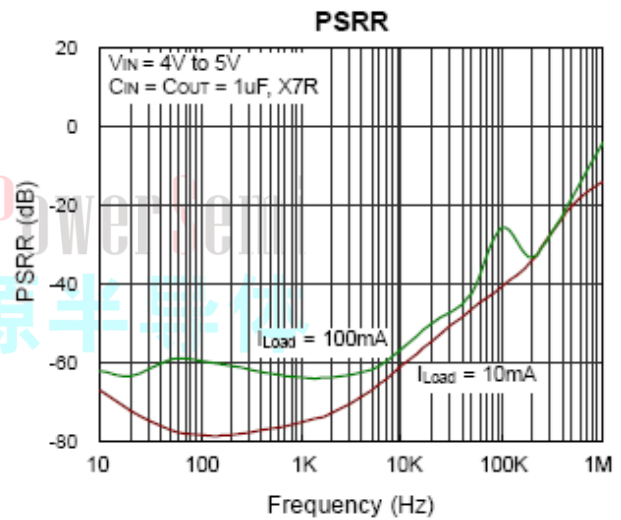
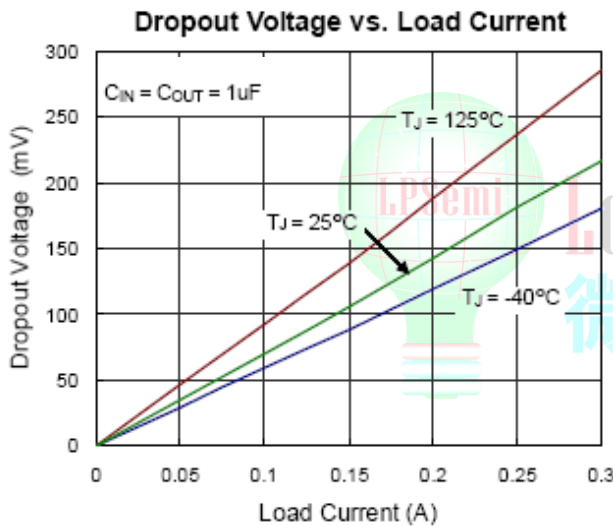
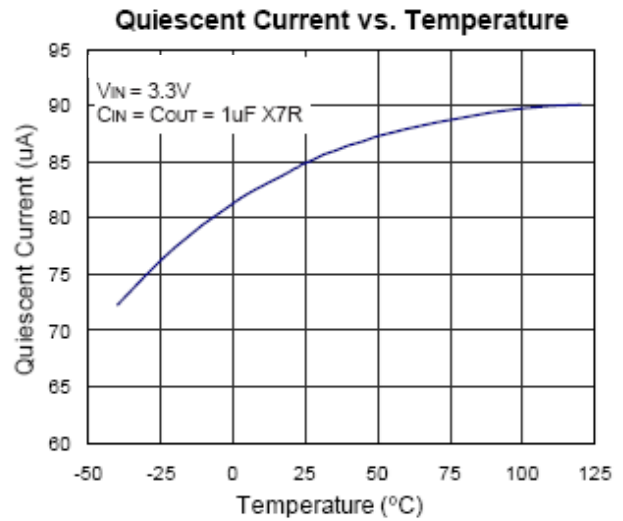
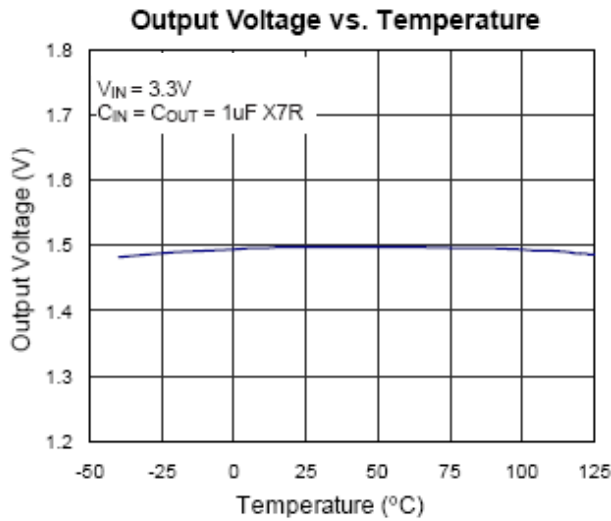

## Applications Information

Like any low-dropout regulator, the external capacitors used with the LP3987H must be carefully selected for regulator stability and performance. Using a capacitor whose value is  $> 1\mu\text{F}$  on the LP3987H input and the amount of capacitance can be increased without limit. The input capacitor must be located a distance of not more than 0.5 inch from the input pin of the IC and returned to a clean analog ground. There is a special attention which is the input capacitance should not be less than output capacitance. Any good quality ceramic or tantalum can be used for this capacitor. The capacitor with larger value and lower ESR (equivalent series resistance) provides better PSRR and line-transient response. The output capacitor must meet both requirements for minimum amount of capacitance and ESR in all LDOs application. The LP3987H is designed specifically to work with low ESR ceramic output capacitor in space-saving and performance consideration. Using a ceramic capacitor whose value is at least  $1\mu\text{F}$  with ESR is  $>25\text{m}\Omega$  on the LP3987H output ensures stability. The LP3987H still works well with output capacitor of other types due to the wide stable ESR range. Output capacitor of larger capacitance can reduce noise and improve load transient response, stability, and PSRR. The output capacitor should be located not more than 0.5 inch from the VOUT pin of the LP3987H and returned to a clean analog ground.

## Thermal Considerations

Thermal protection limits power dissipation in LP3987H. When the operation junction temperature exceeds  $150^\circ\text{C}$ , the OTP circuit starts the thermal shutdown function turn the pass element off. The pass element turns on again after the junction temperature cools by  $25^\circ\text{C}$ . For continue operation, do not exceed absolute maximum operation junction temperature  $125^\circ\text{C}$ .

The power dissipation definition in device is :

$$P_D = (V_{IN} - V_{OUT}) \times I_{OUT} + V_{IN} \times I_Q$$

The maximum power dissipation depends on the thermal resistance of IC package, PCB layout, the rate of surroundings airflow and temperature difference between junction to ambient.

The maximum power dissipation can be calculated by following formula :

$$P_{D(\text{MAX})} = (T_{J(\text{MAX})} - T_A) / \theta_{JA}$$

Where  $T_{J(\text{MAX})}$  is the maximum operation junction temperature  $125^\circ\text{C}$ ,  $T_A$  is the ambient temperature and the  $\theta_{JA}$  is the junction to ambient thermal resistance. For recommended operating conditions specification of LP3987H, where  $T_{J(\text{MAX})}$  is the maximum junction temperature of the die ( $125^\circ\text{C}$ ) and  $T_A$  is the maximum ambient temperature. The junction to ambient thermal resistance ( $\theta_{JA}$  is layout dependent) for SOT23-5 package is  $195^\circ\text{C}/\text{W}$ .

$$P_{D(\text{MAX})} = (125^\circ\text{C} - 25^\circ\text{C}) / 195^\circ\text{C} = 500\text{mW (SOT23-5)}$$

The maximum power dissipation depends on operating ambient temperature for fixed  $T_{J(\text{MAX})}$  and thermal resistance  $\theta_{JA}$ . When considering the thermal characteristic of PCB it may be larger than  $500\text{mW}$ .

### Start-up Function Enable Function

The LP3987H features an LDO regulator enable/disable function. To assure the LDO regulator will switch on, the EN turn on control level must be greater than 1.4 volts. The LDO regulator will go into the shutdown mode when the voltage on the EN pin falls below 0.4 volts. For protecting the system, the LP3987H have a quick-discharge function. If the enable function is not needed in a specific application, it may be tied to VIN to keep the LDO regulator in a continuously on state.

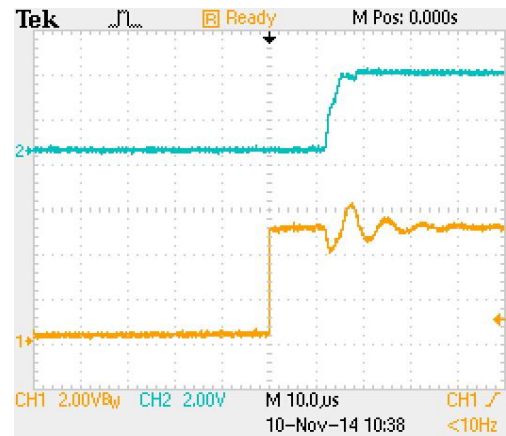

## Packaging Information

SOT23-5

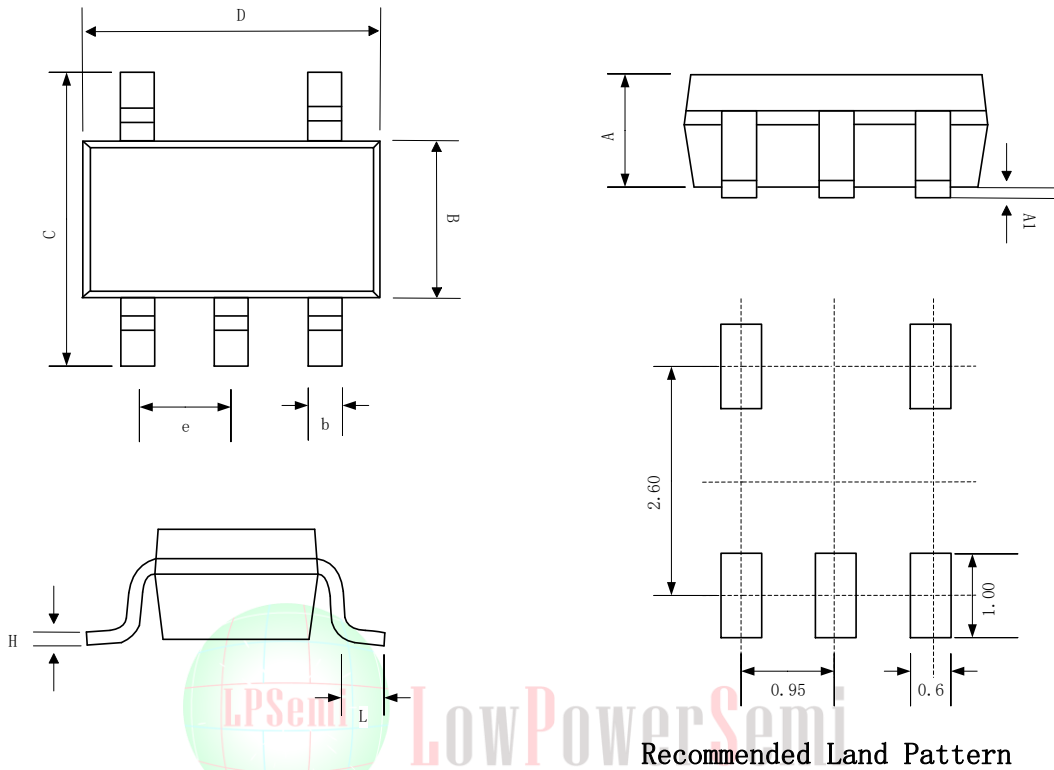

Recommended Land Pattern

SYMBOL	Dimensions In Millimeters		
	MIN	NOM	MAX
A	0.889	1.100	1.295
A1	0.000	0.050	0.152
B	1.397	1.600	1.803
b	0.28	0.35	0.559
C	2.591	2.800	3.000
D	2.692	2.920	3.120
e	0.95BSC		
H	0.080	0.152	0.254
L	0.300	0.450	0.610

## Tape Information

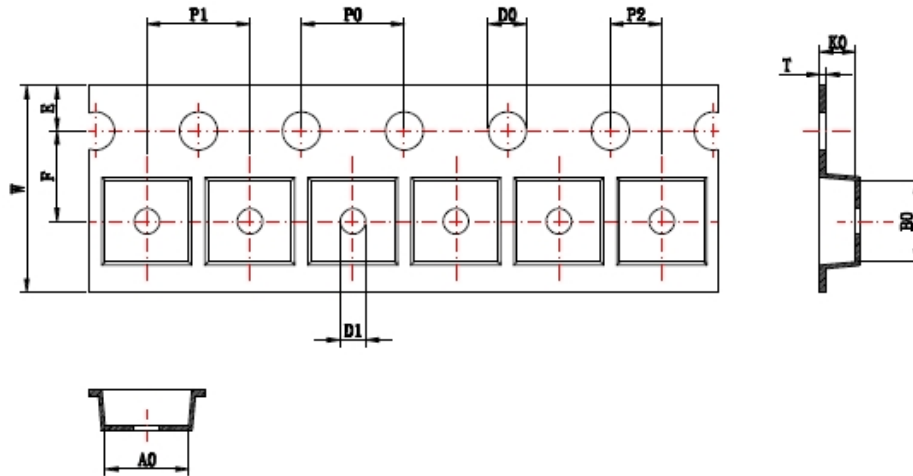

Symbol	Millimeters
A0	3.2±0.15
B0	3.1±0.15
D0	1.55±0.1
D1	1.1±0.1
K0	1.35±0.1
P0	4.0±0.1
P1	4.0±0.1
P2	2.0±0.1
W	8.0±0.1
E	1.75±0.1
F	3.5±0.1

## Classification of IR Reflow Profile

Profile Feature	Sn-Pb Eutectic Assembly	Pb-Free Assembly
<b>Preheat/Soak</b>		
Temperature Min( $T_{SMIN}$ )	100°C	150°C
Temperature Max( $T_{SMAX}$ )	150°C	200°C
Time( $T_S$ ) from ( $T_{SMIN}$ to $T_{SMAX}$ )	60~120 seconds	60~120 seconds
Ramp-up rate ( $T_L$ to $T_P$ )	3°C/second max	3°C/second max
Liquidous temperature( $T_L$ )	183°C	217°C
Time( $t_L$ ) maintained above $T_L$	60~150 seconds	60~150 seconds
Peak package body temperature ( $T_P$ )	For users $T_P$ must not exceed the Classification temp in Table 1. For suppliers $T_P$ must equal or exceed the Classification temp in Table 1.	For users $T_P$ must not exceed the Classification temp in Table 2. For suppliers $T_P$ must equal or exceed the Classification temp in Table 2.
Time( $t_p$ )* within 5°C of the specified classification temperature( $T_C$ ), see Figure1	20* seconds	30* seconds
Ramp-down rate ( $T_P$ to $T_L$ )	6°C/second max	6°C/second max
Time 25°C to peak temperature	6 minutes max	8 minutes max
* Tolerance for peak profile temperature ( $T_P$ ) is defined as a supplier minimum and a user maximum.		

Table 1 Sn-Pb Eutectic Process - Classification Temperatures ( $T_C$ )

Package Thickness	Volume mm <sup>3</sup> <350	Volume mm <sup>3</sup> ≥350
<2.5mm	235°C	220°C
≥2.5mm	220°C	220°C

Table 2 Pb-Free Process - Classification Temperatures ( $T_C$ )

Package Thickness	Volume mm <sup>3</sup> <350	Volume mm <sup>3</sup> 350~2000	Volume mm <sup>3</sup> ≥350
<1.6mm	260°C	260°C	260°C
1.6mm~2.5mm	260°C	250°C	245°C
>2.5mm	250°C	245°C	245°C

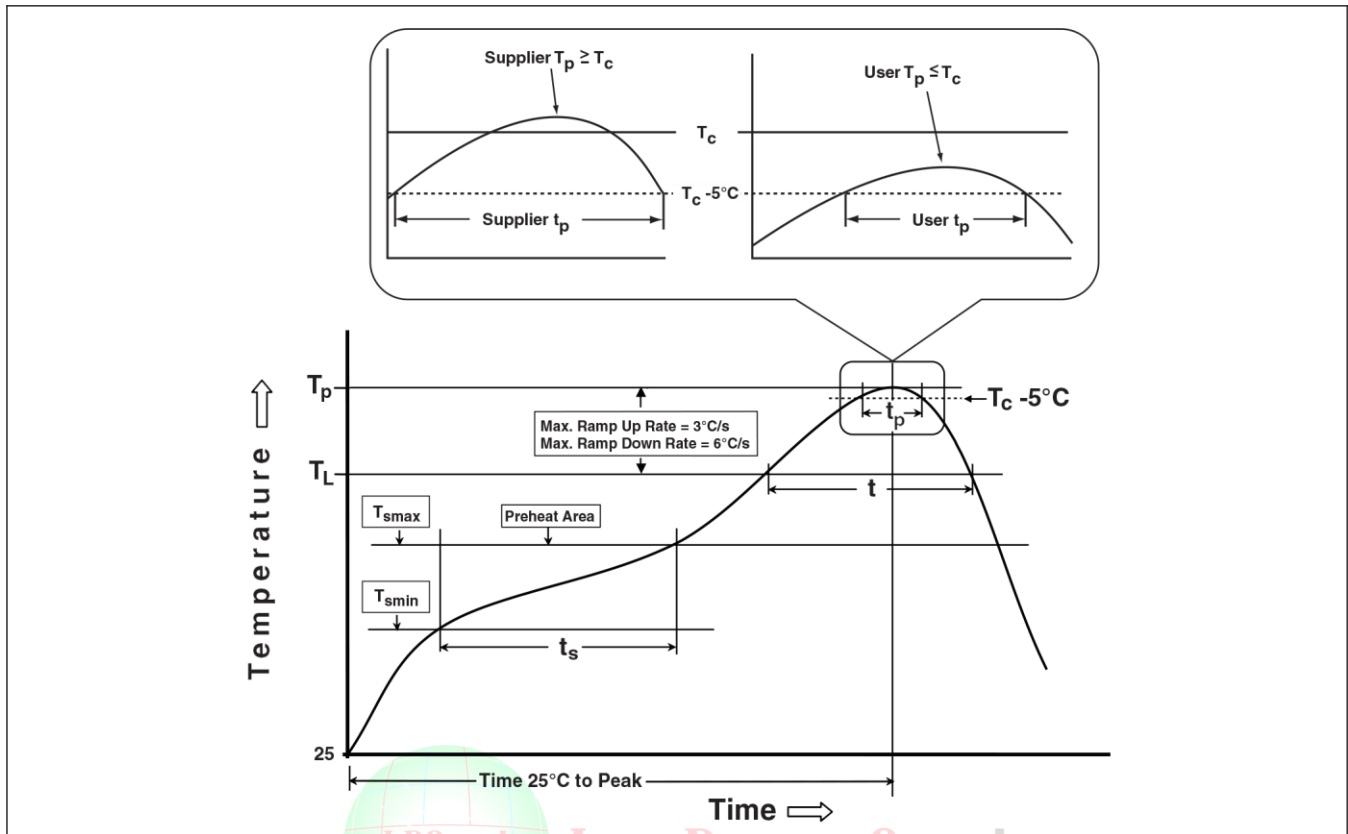

Figure 1 Classification Profile (Not to scale)

Products shipped conform to “Rohs” standards;

Moisture Sensitivity Level: MSL3 (CONDITION:  $\leq 30$  °C/60%RH、Time control:168 hours) ;