



Features

- Input voltage tolerance up to 36V
- 140mΩ on-state resistance
- 130μA low current consumption
- Under-voltage lockout: 2.95V
- Over-voltage protection: 6.05V
- Output discharge integrated
- Output short Protection
- Thermal shutdown protection
- ESD Protection:
 - Human Body Model: 8kV
 - Charged Device Model: 2kV
- Package: SOT23-6

Applications

- E-Cigarette Devices
- Wearable Devices

General Description

The LP5313 is a power switch device provides multiple protection to systems and loads which may encounter large current and input over-voltage conditions.

The device contains a 140mΩ MOSFET which can operate over an input voltage range from 3.0V to 36V. The OVP will disconnect V_{IN} and V_{OUT} when the voltage on V_{IN} is higher than over voltage threshold. When the current reaches the threshold, the device will turn off the power FET to prohibit excessive currents from causing damage. Thermal shutdown protection is integrated which shuts off the MPSFET to prevent damage to the part when the temperature is higher than threshold.

The part is available in space-saving SOT23-6 package.



SOT23-6

Marking Information

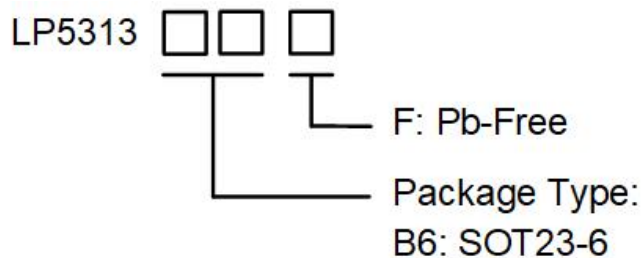

Ordering and Package Information

Part Number	Top Mark	Package	Tape & Reel
LP5313B6F	LPS 8NYWX	SOT23	3K/REEL
Marking indication: Y: Production Year, W: Production week, X: Series Number			



Typical Application Circuitry

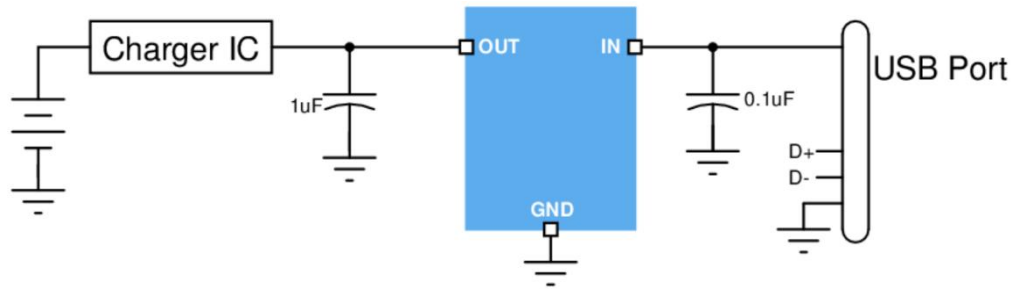
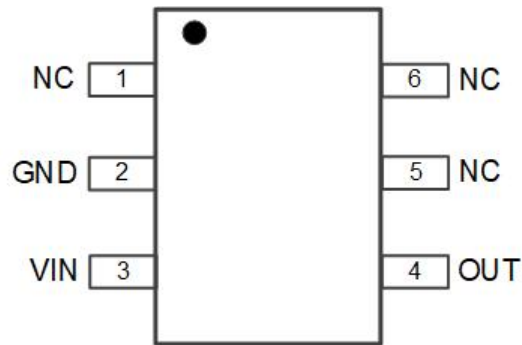

Figure 1. Typical Application Circuitry

Pin Configuration



SOT23-6 (Top View)

Pin Description

Pin No.	Pin Name	Description
1,5,6	NC	Floating
2	GND	Ground
3	VIN	Power supply and input of power switch
4	OUT	Output of power switch



Functional Block Diagram

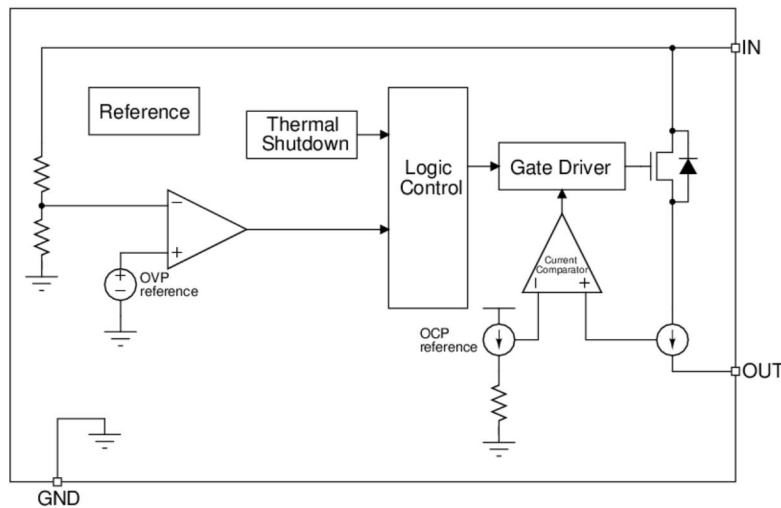

Figure 2. Internal Block Diagram (LP5313)

Absolute Maximum Ratings (Note 1)

- VIN to GND ----- -0.3V to 36V
- VOUT to GND ----- -0.3V to 7V
- Maximum Junction Temperature (T_A) ----- 150°C
- Maximum Soldering Temperature (at leads, 10 seconds) ----- 260°C

Note 1: Stresses beyond those listed under "Absolute Maximum Ratings" may cause permanent damage to the device. These are stress ratings only, instead of functional operation of the device at these or any other conditions beyond those indicated in the operational sections of the specifications. Exposure to absolute maximum rating conditions for extended periods may affect device reliability.

Thermal Information

- Maximum Power Dissipation (P_D, T_A ≤ 25°C) ----- 0.6W
- Thermal Resistance (θ_{JA}) (Note 2) ----- 203°C/W

Note 2: It is based on 2S2P JEDEC standard PCB.

ESD Ratings

- HBM (Human Body Model, JEDEC JS-001) ----- ±8000V
- CDM (Charged Device Model, JEDEC JS-002) ----- ±2000V

Recommended Operating Conditions

- Input Voltage ----- 3.0V to 5.5V
- Maximum of Output current ----- 3A
- Ambient Temperature ----- -40°C to 85°C



Electrical Characteristics

The following parameters are guaranteed under condition $V_{IN} = 5V$, $T_A = -40^{\circ}C$ to $85^{\circ}C$ unless otherwise noted, $T_A = 25^{\circ}C$ for typical value.

Parameters	Symbol	Test conditions	Min	Typ	Max	Unit
On-resistance	$R_{DS(ON)}$	$V_{IN} = 5V$, $I_{OUT} = 200mA$, $T_A = 25^{\circ}C$		140		mΩ
Input quiescent current	I_Q	$V_{IN} = 5V$, OUT floating, $V_{ENB} = 0V$	100	130	160	μA
Under-Voltage Lockout level	V_{UVLO_F}	VIN voltage falling	2.85	2.95	3.05	V
	V_{UVLO_R}	VIN voltage rising	3	3.1	3.2	V
Over-Voltage Protection level	V_{OVP_F}	VIN voltage falling	5.85	5.95	6.05	V
	V_{OVP_R}	VIN voltage rising	5.95	6.05	6.15	V
Over current protection level	I_{OCP}	$V_{IN} = 5V$, $T_A = 25^{\circ}C$		4		A
Over-Voltage Protection response time	t_{OVP}	V_{IN} rising from 5V with $30V/\mu s$, $R_{OUT} = 100\Omega$, $C_{OUT} = 0$, time from $V_{IN} > V_{OVP_R}$ to OUT voltage stop rising		30	50	ns
Output auto discharge ^(Note 3)	R_{DIS}	$V_{IN} = 5V$, $V_{EN} = 0V$	200	250	300	Ω
OCP qualification time ^(note 3)	t_{OCP_QUAL}	$V_{IN} = 5V$, $T_A = 25^{\circ}C$, qualification time from I_{OUT} hits I_{OCP} to switch turned off		150		μs
Load switch turned on delay	t_{DON}	$V_{IN} = 5V$, $R_{OUT} = 100\Omega$, $C_{OUT} = 22\mu F$, time from enabled to $V_{OUT} = 0.5V$	12	16	20	ms
Output rising time ^(Note 3)	t_R	$V_{IN} = 5V$, $R_{OUT} = 100\Omega$, $C_{OUT} = 22\mu F$, time from $V_{OUT} = 0.1 \times V_{IN}$ to $0.9 \times V_{IN}$	100	150	200	μs
Load switch turned off delay	t_{OFF}	$V_{IN} = 5V$, $R_{OUT} = 500\Omega$, $C_{OUT} = 0.1\mu F$, time from disabled to $V_{OUT} = 0.9 \times V_{IN}$		10		μs
Thermal shutdown trigger	T_{SD}	Temperature rising		150		°C
Thermal shutdown release	T_{SD_REL}	Temperature falling		130		°C

Note 3. The parameter is guaranteed by design and characterization.



Typical Timing Diagram

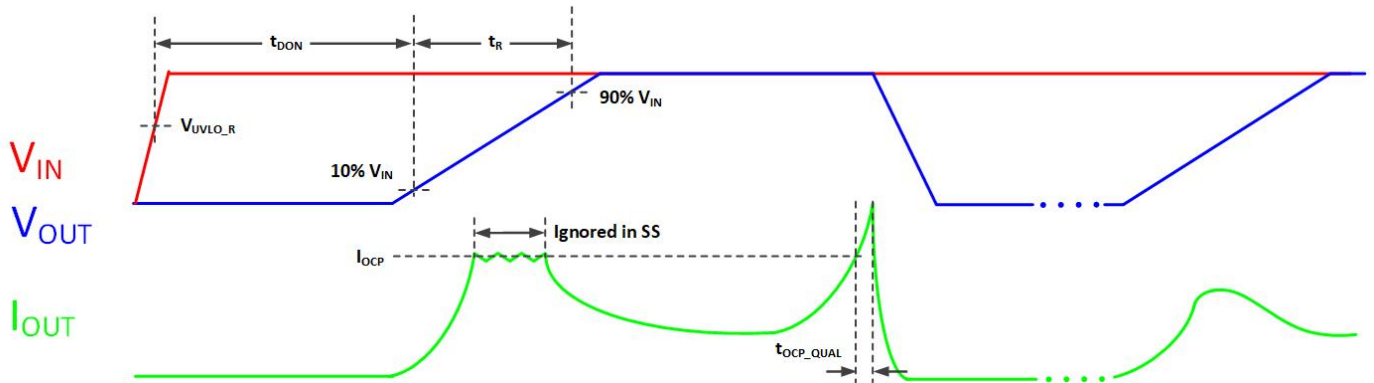

Figure 3. Start-up and over current protection

Typical Performance Characteristics

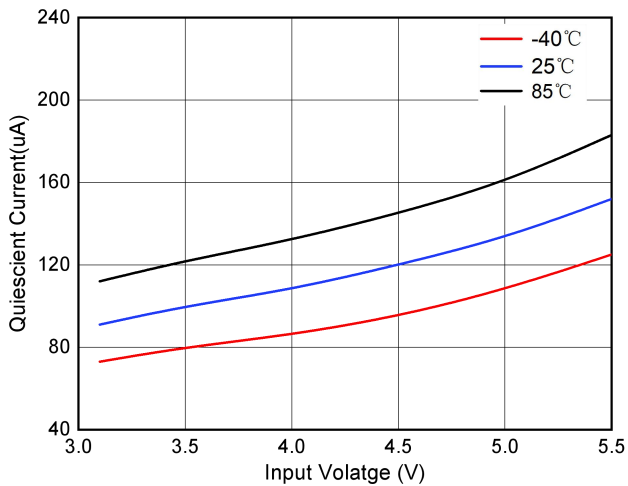

Figure 4. Quiescent Current vs Temperature and V_{IN}
($C_{IN}=C_{OUT}=1\mu F$, no load)

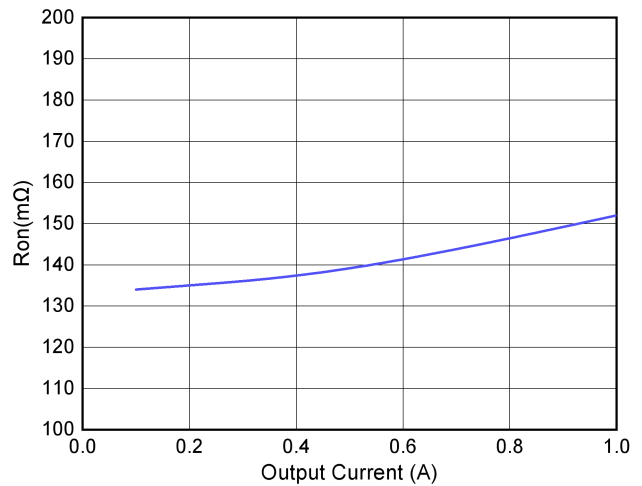

Figure 5. On-resistance vs. I_{out}
($C_{IN}=C_{OUT}=1\mu F$, $V_{IN} = 5V$)



Typical Operating Waveforms

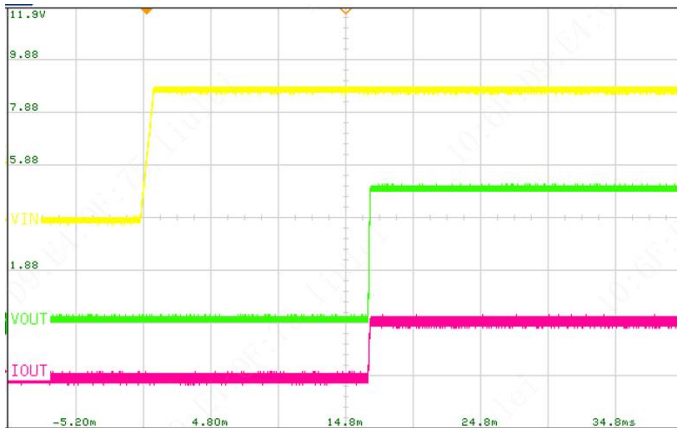

Figure 6. Start-up Relative to V_{IN}
($C_{IN}=C_{OUT}=1\mu F$, $R_{LOAD} = 100\Omega$)

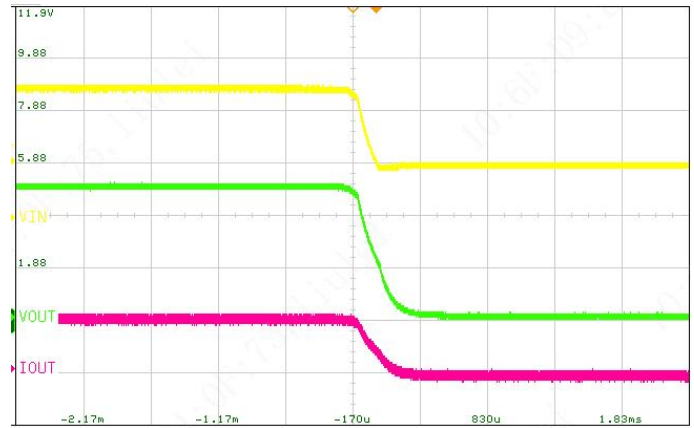

Figure 7. Shut-down Relative to V_{IN}
($C_{IN}=C_{OUT}=1\mu F$, $R_{LOAD} = 100\Omega$)

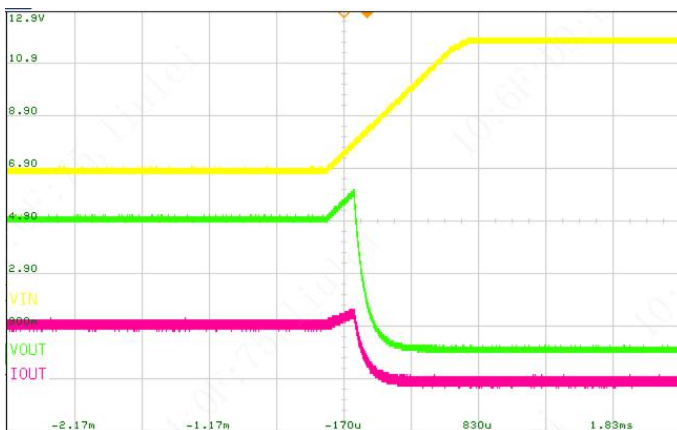

Figure 8. Over-Voltage Protection Response
(V_{IN} from 5V to 10V, $C_{IN}=C_{OUT}=1\mu F$, $R_{LOAD} = 100\Omega$)

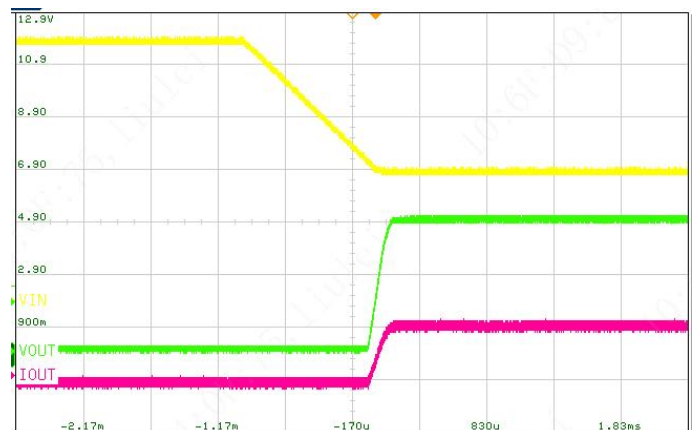

Figure 9. Over-Voltage Protection Recovery
(V_{IN} from 10V to 5V, $C_{IN}=C_{OUT}=1\mu F$, $R_{LOAD} = 100\Omega$)

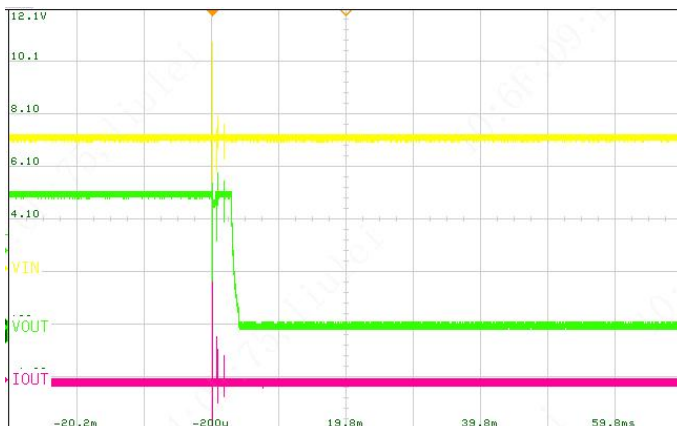

Figure 10. Output Short Protection Response
($C_{IN}=C_{OUT}=1\mu F$, OUT short to GND)



Function Description

General Description

LP5313 is an OVP power switch integrated multiple protection to protect systems and loads which can be damaged or disrupted by the application of high currents or high temperature. The device contains a 140mΩ N-channel MOSFET and a controller capable of working over a wide input operating range of 3V to 36V. The controller protects against system malfunctions through over-current protection, under-voltage lockout and thermal shutdown.

Output short Protection

When the OUT Pin of LP5313 is connected to GND, the current through the MOSFET will reach the OCP value, the OCP feature ensures that the device will disconnect output from input. Once the switch is turned off, it will not conduct again unless the V_{IN} falls below the V_{UVLO_F} and then rises over the V_{UVLO_R} .

Over-Voltage Protection

The LP5313 has Over-Voltage protection to prevent high voltage on V_{IN} passing through to V_{OUT} . Once the voltage on input exceeds the OVP threshold, the power FET will be turned off immediately. When V_{IN} drop back below OVP release level, the switch will be turned on again after a 70μs de-bounce time.

Under-Voltage Lockout

The under-voltage lockout turns-off the switch if the input voltage drops below the under-voltage lockout threshold. The input voltage rising above the under-voltage lockout threshold more than 16ms will cause a controlled turn-on of the switch which limits current over-shoots.

Thermal Shutdown

The thermal shutdown protects the device from internally or externally generated excessive temperatures. During an over temperature condition, the switch is turned off. The switch automatically turns on again if the temperature drops below the threshold temperature.



Packaging Information

SOT23-6

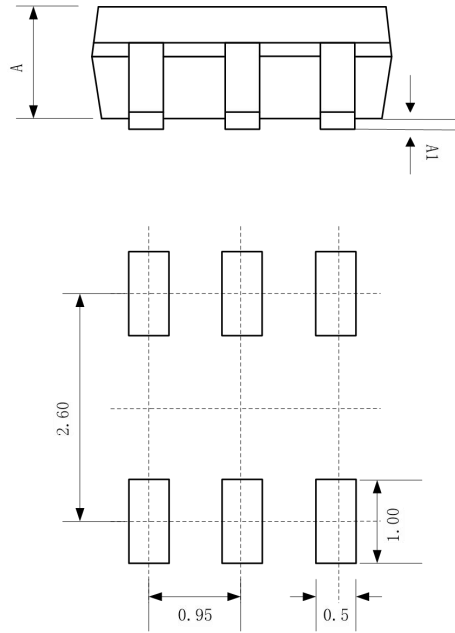
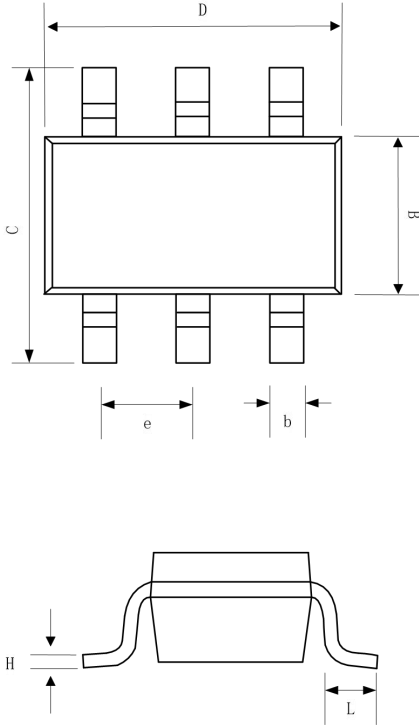

Recommended Land Pattern

SYMBOL	MILLIMETER		
	MIN	NOM	MAX
A	0.889	1.100	1.295
A1	0.000	0.050	0.152
B	1.397	1.600	1.803
b	0.28	0.35	0.559
C	2.591	2.800	3.000
D	2.692	2.920	3.120
e	0.95BSC		
H	0.080	0.152	0.254
L	0.300	0.450	0.610



Tape and Reel information

REEL DIMENSIONS (Unit:mm)

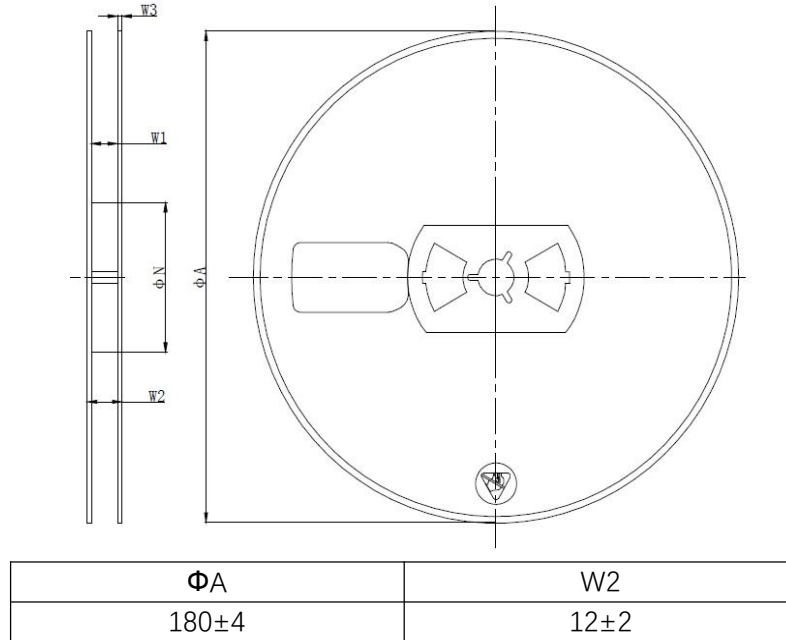

TAPE DIMENSIONS (Unit:mm)

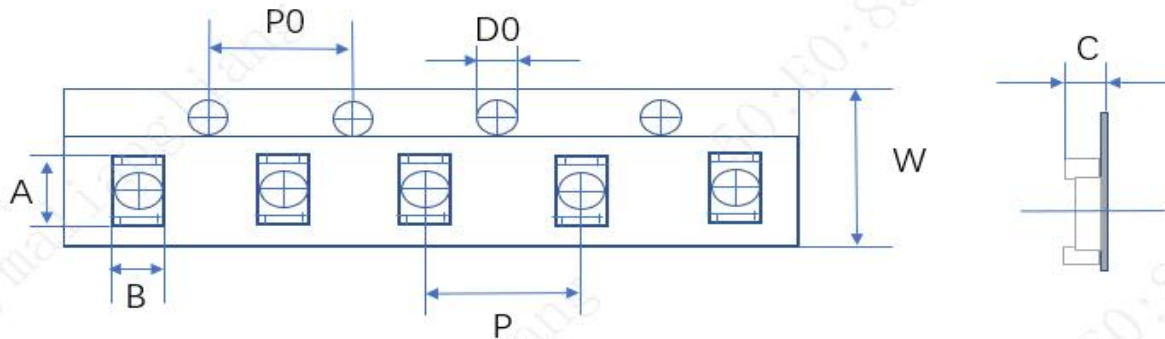

口袋宽度A		口袋长度B		编带孔中心间距P0		IC中心间距P		孔径D0		编带宽度W		编带厚度C	
尺寸(mm)	公差	尺寸(mm)	公差	尺寸(mm)	公差	尺寸(mm)	公差	尺寸(mm)	公差	尺寸(mm)	公差	尺寸(mm)	公差
3.2	±0.2	3.26	±0.2	4	±0.1	4	±0.1	1.5	±0.15	8	±0.3	1.4	±0.2

PIN1 AND TAPE FEEDING DIRECTION

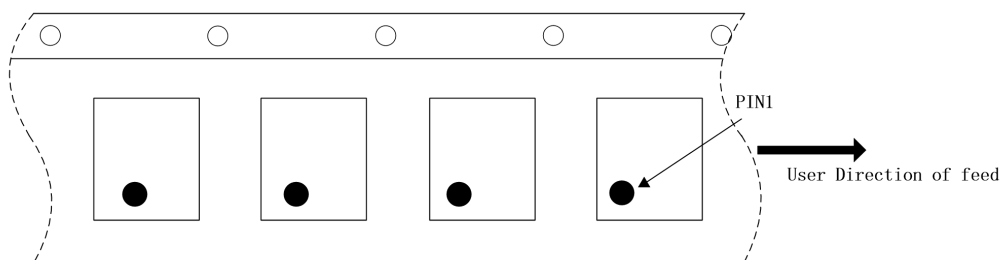



Revision History

Revision	Date	Change Description
Rev 1p0	02/04/2024	First release version